

RP231026D/E

NMOS 1Mbit MASK ROM (131,073 word × 8 bit)

■ GENERAL DESCRIPTION

The RP231026D/E is a static NMOS read only Memory organized as 131,072 words by 8 bits and operates from a single +5V supply.

The RP231026D/E features automatic power-down mode. When Chip Enable (\overline{CE}) goes HIGH level, the supply current is reduced from 100mA (max.) to 30mA (max.).

Pin 20 can be used as OE.

According to your order, Logic of the OE pin may be selected ACTIVE LOW or ACTIVE HIGH.

■ FEATURES

- 131,072 words × 8 bits organization
- Low power dissipation

Active	550mW max.
Standby	165mW max.
- Fast access time

RP231026D	250ns max.
RP231026E	200ns max.
- Single +5V ($\pm 10\%$) power supply
- Completely TTL compatible: All outputs and inputs
- 3-state outputs for wired-OR expansion
- Pin compatible with Intel 27512

■ BLOCK DIAGRAM

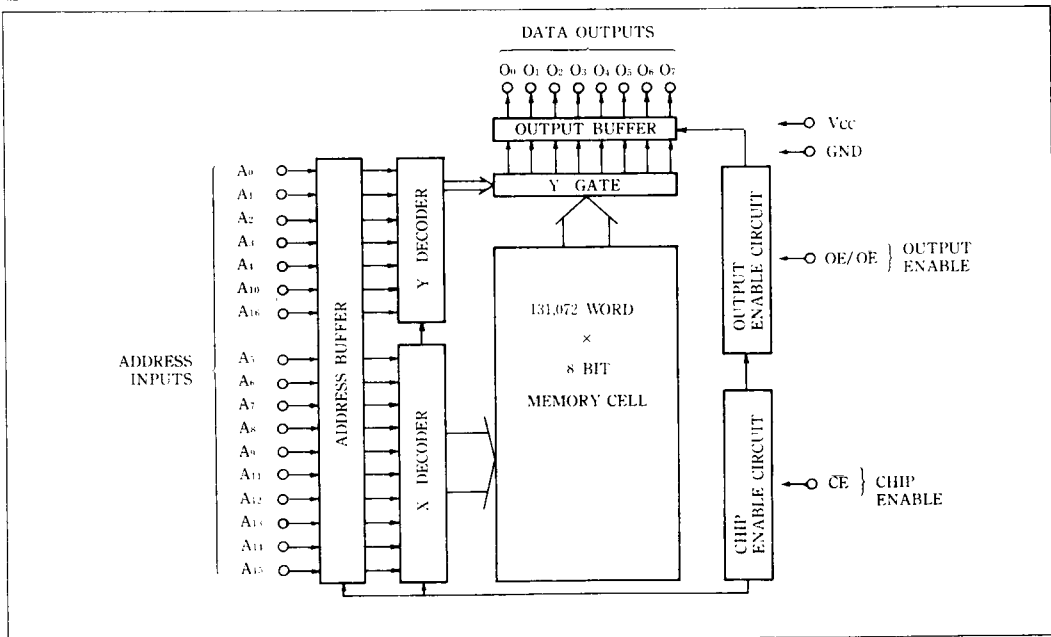

■ PIN CONFIGURATION (Top view)

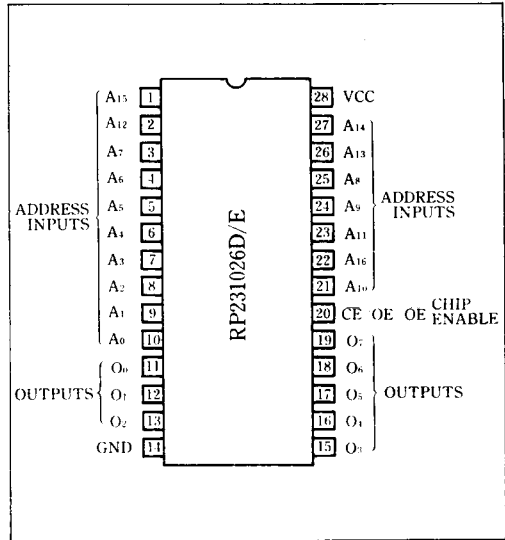

■ ABSOLUTE MAXIMUM RATINGS

Symbol	Parameter	Condition	Limit	Unit
V _{CC}	Supply Voltage	With respect to GND	-0.3~7	V
V _I	Input Voltage		-0.3~V _{CC} +0.3	V
V _O	Output Voltage		-0.3~V _{CC} +0.3	V
P _d	Maximum Power Dissipation	T _a = 25°C	700	mW
T _{opr}	Operating Ambient Temperature		0~70	°C
T _{stg}	Storage Temperature		-40~125	°C

■ RECOMMENDED OPERATING CONDITIONS (T_a = 0~70°C)

Symbol	Parameter	Specified Value			Unit
		Min	Typ	Max	
V _{CC}	Supply Voltage	4.5	5.0	5.5	V
V _{IH}	Input High Voltage	2.0		V _{CC}	V
V _{IL}	Input Low Voltage	-0.3		0.8	V

■ ELECTRICAL CHARACTERISTICS

● DC ELECTRICAL CHARACTERISTICS (T_a = 0~70°C, V_{CC} = 5V ± 10%)

Symbol	Parameter	Test Condition	Specified Value			Unit
			Min	Typ	Max	
I _{CC1}	Supply Current (Standby)	CE = V _{CC}			30	mA
I _{CC2}	Supply Current (Active)	I _o = 0mA			100	mA
V _{OIH}	Output High Voltage	I _{OH} = -400μA	2.4		V _{CC}	V
V _{OIL}	Output Low Voltage	I _{OL} = 2.0mA			0.1	V
V _{IH}	Input High Voltage		2.0			V
V _{IL}	Input Low Voltage		-0.3		0.8	V
I _{L1}	Input Leakage Current	V _I = 0V~V _{CC}	-10		10	μA
I _{LO}	Output Leakage Current	V _o = V _{CC} ·Chip Deselected	-10		10	μA

● AC ELECTRICAL CHARACTERISTICS (T_a = 0~70°C, V_{CC} = 5V ± 10%)

Symbol	Parameter	Specified Value						Unit
		RP231026D			RP231026E			
		Min	Typ	Max	Min	Typ	Max	
t _{ACC}	Address Access Time			250			200	ns
t _{CE}	Chip Enable Access Time			250			200	ns
t _{OE}	Output Enable Access Time			100			80	ns
t _{DF}	Output Floating Delay Time	0		100	0		80	ns
t _{OH}	Output Hold Time	0			0			ns

Note) Test Condition

Input Pulse Voltage: V_{IL} = 0.6V, V_{IH} = 2.4V

Input Pulse Rise/Fall Time: 10ns

Timing Measuring Voltage: Input V_{IL} = 0.8V, V_{IH} = 2.2V

Output V_{OL} = 0.8V, V_{OIH} = 2.0V

Output Load: 1TTL + 100pF (including jig capacitance)

● TERMINAL CAPACITANCE

Symbol	Parameter	Test Condition	Specified Value			Unit
			Min	Typ	Max	
C _i	Input Capacitance	f = 1MHz			8	pF
C _o	Output Capacitance				12	pF

■ TIMING CHART

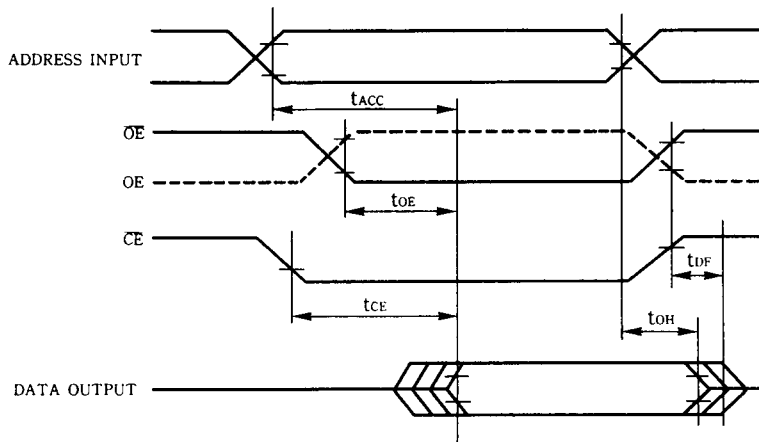

■ 28 PIN PLASTIC PACKAGE (Unit:mm)

