

DRAWING FOR REFERENCE: This is subject to change without notice
08/11/2012

POSITION OF THE WRENCH AND DO NOT NECESSARILY MATCH THE DRAWING.

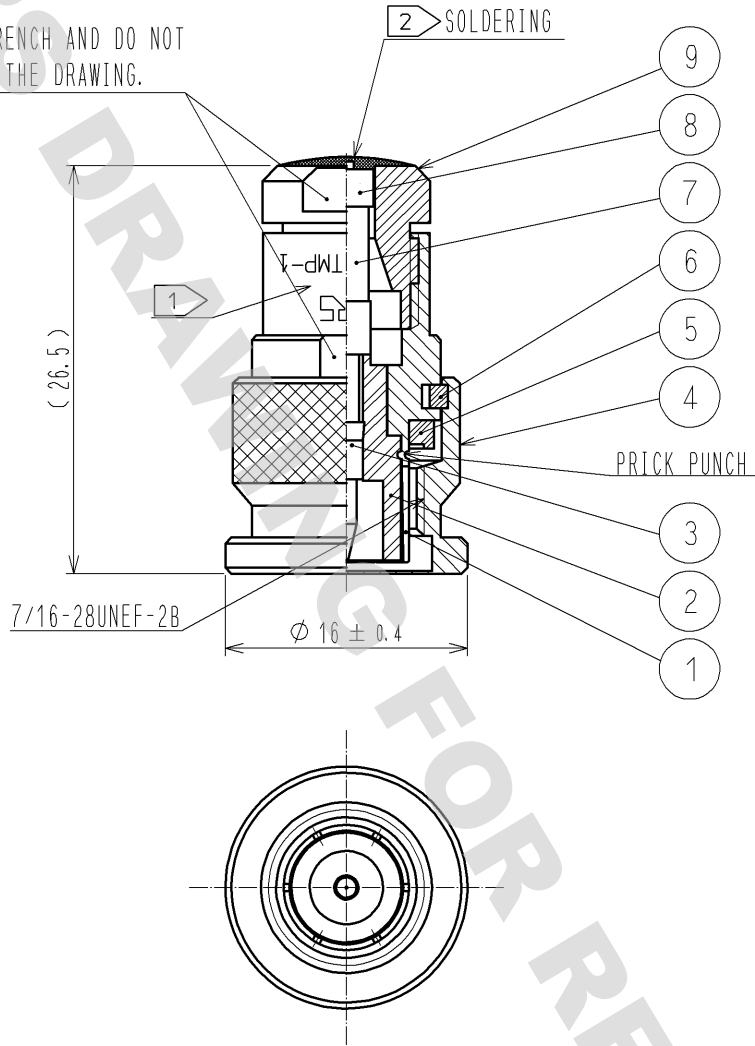

NOTES 1 TNC-TMP-1 AND HRS MARKING SHALL BE INDICATED AT THE POSITION AS SHOWN.
2 USE LEAD FREE SOLDER(Sn3.0Ag0.5Cu).

5	SILICONE RUBBER		9	BRASS	NICKEL PLATING
4	BRASS	NICKEL PLATING	8	BRASS	GOLD PLATING
3	BRASS	GOLD PLATING	7	RESISTANCE	50Ω
2	PTFE		6	PHOSPHOR BRONZE	NICKEL PLATING
1	BRASS	NICKEL PLATING			
NO.	MATERIAL	FINISH . REMARKS	NO.	MATERIAL	FINISH . REMARKS
UNITS mm		SCALE 2 : 1		COUNT	
HIROSE ELECTRIC CO., LTD.		APPROVED : MT. SHIBUTANI 12. 04. 17		DRAWING NO. EDC4-030141-01	
		CHECKED : TK. SAWAGUCHI 12. 04. 16		PART NO. TNC-TMP-1(50)	
		DESIGNED : KY. SHIMIZU 12. 04. 12		CODE NO. CL353-0053-7-50	
		DRAWN : KY. SHIMIZU 12. 04. 12		1/1	