

# High Performance 2048x8 PROM TiW PROM Family

## 53/63S1681 53/63S1681A

### Features/Benefits

- 35 ns maximum access time
- 16384-bit memory
- Reliable titanium-tungsten fuses (TiW)
- Pin-compatible with standard Schottky PROMs
- Available in space saving SKINNYDIP® package

### Applications

- Microprogram control stores
- Microprocessor program store
- Look-up table
- Character generator
- Code converter
- Programmable Logic Element (PLE™) 11 inputs, 8 outputs, 2048 product terms per output

### Description

The 53/63S1681 is a high-speed 2Kx8 PROM which uses industry standard package and pin out. In addition, the device is available in the 24-pin (0.3 in.) SKINNYDIP®.

The family features low current PNP inputs, full Schottky clamping and three-state outputs. The Titanium-Tungsten fuses store a logical low and are programmed to the high state. Special on-chip circuitry and extra fuses provide preprogramming tests which assure high programming yields and high reliability.

The 63 series is specified for operation over the commercial temperature and voltage range. The 53 series is specified for the military ranges.

### Programming

The 53/63S1681 PROM is programmed with the same programming algorithm as all other Monolithic Memories' generic TiW PROMs. For details contact the factory.

### Selection Guide

MEMORY			PACKAGE		PERFORMANCE	PART NUMBER	
SIZE	ORGANIZATION	OUTPUT	PINS	TYPE		0°C to +75°C	-55°C to +125°C
16K	2048x8	TS	24 (28)	N,NS, J,JS,W, (NL),(L)	Standard	63S1681	53S1681
					Enhanced	63S1681A	53S1681A

### Pin Configurations

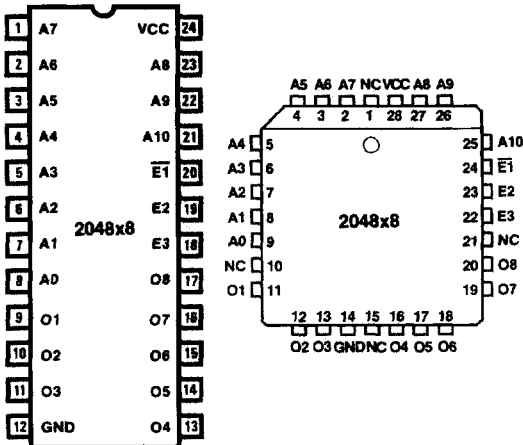

### Block Diagram

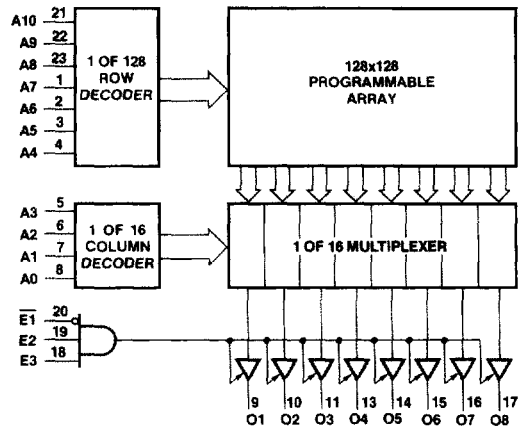

SKINNYDIP® is a registered trademark of Monolithic Memories.

PLE™ is a trademark of Monolithic Memories.

2175 Mission College Blvd. Santa Clara, CA 95054-1592 Tel: (408) 970-9700 TWX: 910-338-2374

2175 Mission College Blvd. Santa Clara, CA 95054-1592 Tel: (408) 970-9700 TWX: 910-338-2374

**Monolithic Memories**

**Absolute Maximum Ratings**

	<b>Operating</b>	<b>Programming</b>
Supply voltage $V_{CC}$ .....	-0.5 V to 7 V	12 V
Input voltage .....	-1.5 V to 7 V	7 V
Input current .....	-30 mA to +5 mA	
Off-state output voltage .....	-0.5 V to 5.5 V	12 V
Storage temperature .....	-65°C to +150°C	

**Operating Conditions**

SYMBOL	PARAMETER	MILITARY			COMMERCIAL			UNIT
		MIN	TYP†	MAX	MIN	TYP†	MAX	
$V_{CC}$	Supply voltage	4.5	5	5.5	4.75	5	5.25	V
$T_A$	Operating free air temperature	-55		125	0		75	°C

**Electrical Characteristics Over Operating Conditions**

SYMBOL	PARAMETER	TEST CONDITION		MIN TYP† MAX		UNIT	
$V_{IL}$	Low-level input voltage				0.8	V	
$V_{IH}$	High-level input voltage			2		V	
$V_{IC}$	Input clamp voltage	$V_{CC} = \text{MIN}$	$I_I = -18 \text{ mA}$		-1.5	V	
$I_{IL}$	Low-level input current	$V_{CC} = \text{MAX}$	$V_I = 0.4 \text{ V}$		-0.25	mA	
$I_{IH}$	High-level input current	$V_{CC} = \text{MAX}$	$V_I = V_{CC} \text{ MAX}$		40	μA	
$V_{OL}$	Low-level output voltage	$V_{CC} = \text{MIN}$	$I_{OL} = 16 \text{ mA}$	MIL	0.5	V	
				COM	0.45		
$V_{OH}$	High-level output voltage	$V_{CC} = \text{MIN}$	MIL $I_{OH} = -2 \text{ mA}$	2.4		V	
			COM $I_{OH} = -3.2 \text{ mA}$				
$I_{OZL}$	Off-state output current	$V_{CC} = \text{MAX}$	$V_O = 0.4 \text{ V}$		-40	μA	
$I_{OZH}$			$V_O = 2.4 \text{ V}$		40		
$I_{OS}$	Output short-circuit current*	$V_{CC} = 5 \text{ V}$	$V_O = 0 \text{ V}$	-20	-90	mA	
$I_{CC}$	Supply current	$V_{CC} = \text{MAX}$ . All inputs TTL, all outputs open.			130	175	mA

**Switching Characteristics Over Operating Conditions (See standard test load)**

OPERATING CONDITIONS	DEVICE TYPE	$t_{AA}$ (ns)		$t_{EA}$ AND $t_{ER}$ (ns)		UNIT
		ADDRESS ACCESS TIME		ENABLE ACCESS TIME RECOVERY TIME		
		TYP†	MAX	TYP†	MAX	
COMMERCIAL	63S1681A	27	35	18	25	ns
	63S1681	27	50	18	30	
MILITARY	53S1681A	27	45	18	35	
	53S1681	27	60	18	35	

\* Not more than one output should be shorted at a time and duration of the short-circuit should not exceed one second.

† Typical at 5.0 V  $V_{CC}$  and 25° C  $T_A$ .

**Typical  $I_{CC}$  vs Temperature**

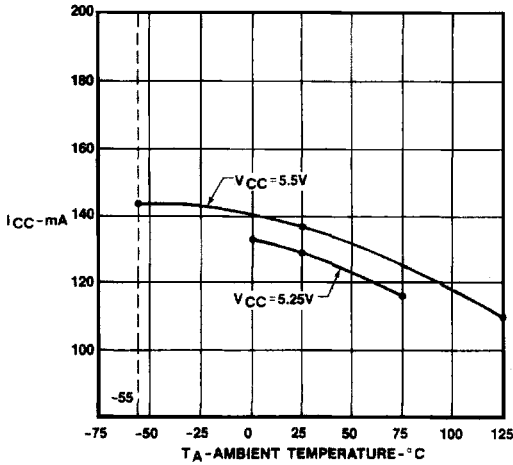

**Typical  $T_{AA}$  vs Temperature**

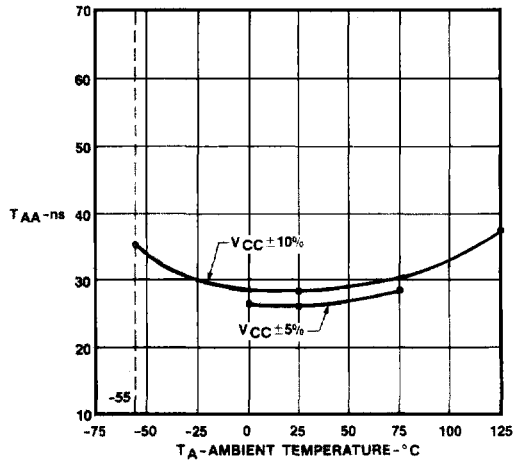

3

**Switching Test Load**

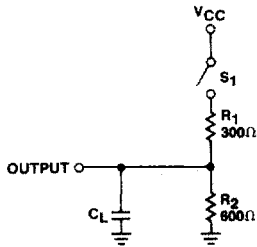

**Definition of Timing Diagram**

WAVEFORM	INPUTS	OUTPUTS
	DON'T CARE; CHANGE PERMITTED	CHANGING; STATE UNKNOWN
	NOT APPLICABLE	CENTER LINE IS HIGH IMPEDANCE STATE
	MUST BE STEADY	WILL BE STEADY

**Definition of Waveforms**

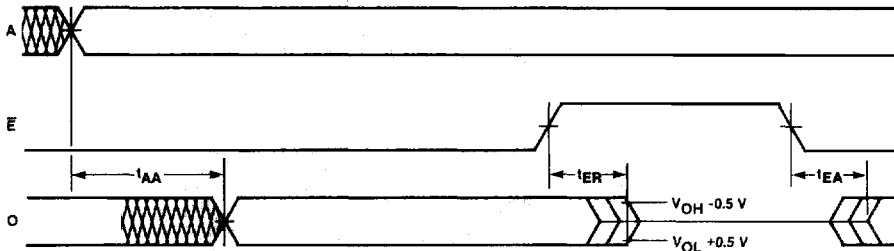

- NOTES:
1. Input pulse amplitude 0 V to 3.0 V.
  2. Input rise and fall times 2-5 ns from 0.8 V to 2.0 V.
  3. Input access measured at the 1.5 V level.
  4.  $t_{AA}$  is tested with switch  $S_1$  closed,  $C_L = 30$  pF and measured at 1.5 V output level.
  5.  $t_{EA}$  is measured at the 1.5 V output level with  $C_L = 30$  pF.  $S_1$  is open for high impedance to "1" test, and closed for high impedance to "0" test.  $t_{ER}$  is tested with  $C_L = 5$  pF.  $S_1$  is open for "1" to high impedance test, measured at  $V_{OH} - 0.5$  output level;  $S_1$  is closed for "0" to high impedance test measured at  $V_{OL} + 0.5$  V output level.

## Commercial Programmers

Monolithic Memories PROMs are designed and tested to give a programming yield greater than 98%. If your programming yield is lower, check your programmer. It may not be properly calibrated.

Programming is final manufacturing — it must be quality-controlled. Equipment must be calibrated as a regular routine,

ideally under the actual conditions of use. Each time a new board or a new programming module is inserted, the whole system should be checked. Both timing and voltages must meet published specifications for the device.

**Remember — The best PROMs available can be made unreliable by improper programming techniques.**

### PROM PROGRAMMING EQUIPMENT INFORMATION

#### SOURCE AND LOCATION

Data I/O Corp.  
10525 Willows Rd. N.E.  
Redmond, WA 98073

Kontron Electronics, Inc.  
630 Price Ave.  
Redwood City, CA 94063

Digelec Inc.  
586 Weddell Dr. Suite 1  
Sunnyvale, CA 94089

Stag Microsystems Inc.  
528-5 Weddell Dr.  
Sunnyvale, CA 94089

## Metal Mask Layout

