



DESIGNED & DIMENSIONED
IN MILLIMETERS [INCHES]

BNC7T-P-C-XX-RA-CA6

GENDER
-P: PLUG

TYPE
-C: CABLE

TERMINATION
-CA6: CCA-6 CABLE (RG-6)

ORIENTATION
-RA: RIGHT ANGLE

PLATING
-GN: GOLD / NICKEL
10µ" Au / 50µ" Ni MIN ON PIN
100µ" Ni MIN ON OUTER CONTACT
(SEE TABLE 1)

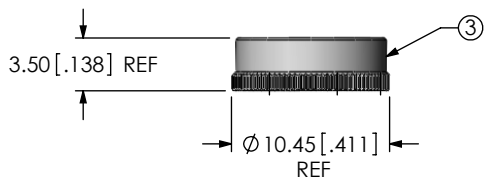
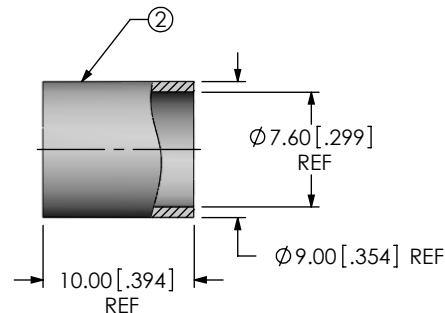
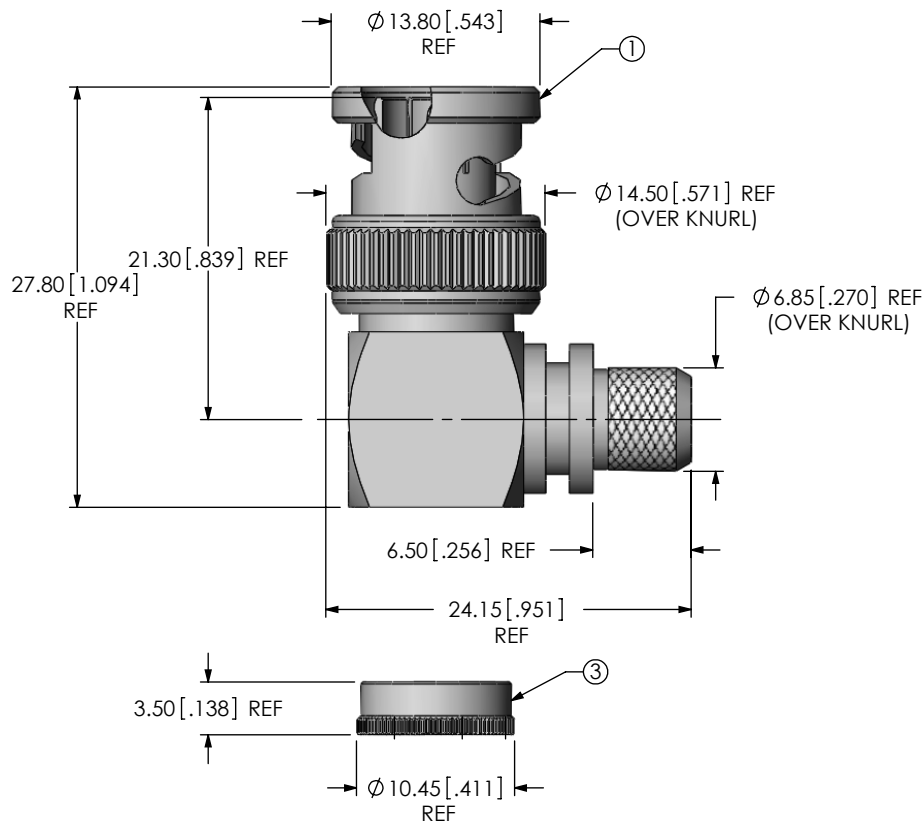

TABLE 1

ITEM	COMPONENT	-GN
1	SUB ASSEMBLY	SUB-BNC7T-P-C-GN-RA-CA6
2	FERRULE	BNC-FER-001-N
3	CAP	BNC7T-P-C-N-RA-CA6-CAP

NOTES:

- ① REPRESENTS A CRITICAL DIMENSION.
- PUSHOUT FORCE FOR CENTER CONTACT: 26.69N [6LBS] MIN.
- SEE SHEET 3 FOR TERMINATION INFORMATION.
- NOTE DELETED.
- PRODUCT TO BE PACKAGED PER PACKAGING STANDARD CO-HD-WI-3040-M.
- RoHS COMPLIANT.
- NOTE DELETED
- NOTE DELETED

<p>UNLESS OTHERWISE SPECIFIED DIMENSIONS ARE IN MILLIMETERS [INCHES]</p> <p>TOLERANCES ARE:</p> <p>DECIMALS ANGLES</p> <p>.X: ±0.3 [.01] 5 °</p> <p>.XX: ±0.13 [.005]</p> <p>.XXX: ±0.051 [.0020]</p>	<p>PROPRIETARY NOTE</p> <p>THIS DOCUMENT CONTAINS INFORMATION CONFIDENTIAL AND PROPRIETARY TO SAMTEC, INC. AND SHALL NOT BE REPRODUCED OR TRANSFERRED TO OTHER DOCUMENTS OR DISCLOSED TO OTHERS OR USED FOR ANY PURPOSE OTHER THAN THAT WHICH IT WAS OBTAINED WITHOUT THE EXPRESSED WRITTEN CONSENT OF SAMTEC, INC.</p>		
		<p>520 PARK EAST BLVD. NEW ALBANY, IN 47150 PHONE: 812-944-6733 FAX: 812-948-5047 e-Mail: info@SAMTEC.com code 55322</p>	
<p>MATERIAL: DO NOT SCALE DRAWING SHEET SCALE: 2:1</p> <p>SHELL, FERRULE, NUT, CAP: BRASS</p> <p>CONTACT: BRASS</p> <p>DIELECTRIC: PTFE</p> <p>GASKET: SILICONE</p>		<p>DESCRIPTION: TRUE 75 OHM, BNC RA RG6 CABLE PLUG</p>	
		<p>DWG. NO. BNC7T-P-C-XX-RA-CA6</p>	
		<p>BY: G. HERMAN 01/09/2009</p>	<p>SHEET 1 OF 2</p>

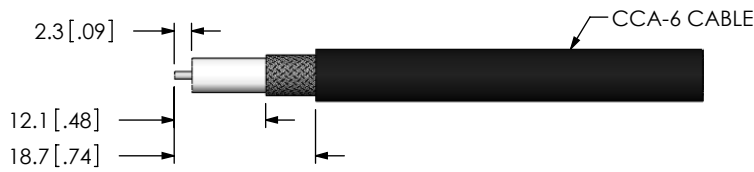
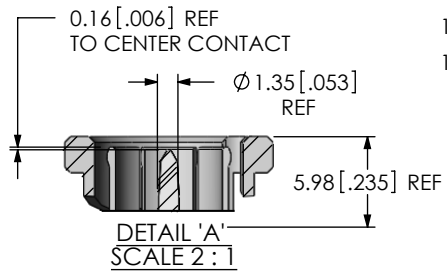

STRIP AND TIN INNER CONDUCTOR

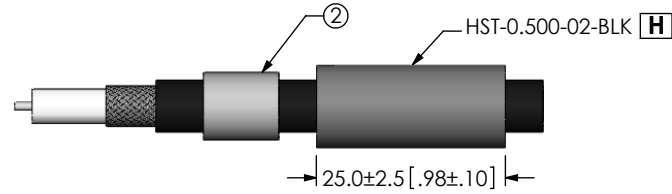

ADD HEAT SHRINK TUBE AND FERRULE

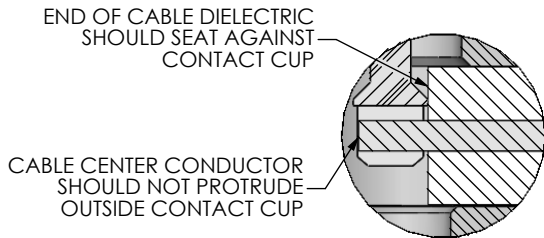

DETAIL 'C' SCALE 4:1

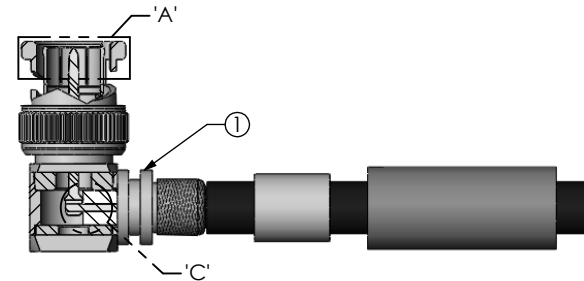

FLAIR BRAID AND ADD SUB-BNC7T-P-C-XX-RA-CA6 AND SOLDER SIGNAL PIN CABLE FOIL WRAP TO BE INSERTED INSIDE CABLE BODY

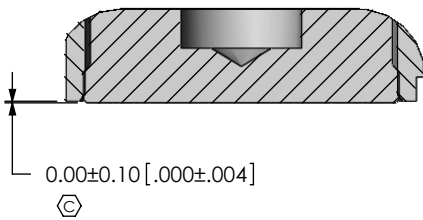

DETAIL 'B' SCALE 4:1

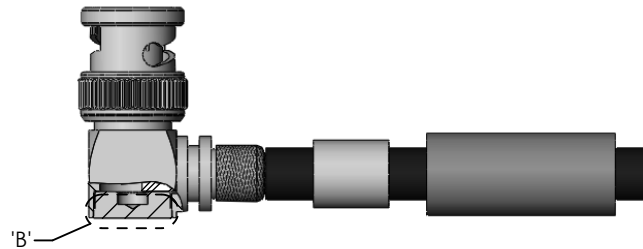

INSERT CAP

CRIMP FERRULE (USE RF CRIMP HAND TOOL # CAT-HT-T26667-21 OR EQUIVALENT)

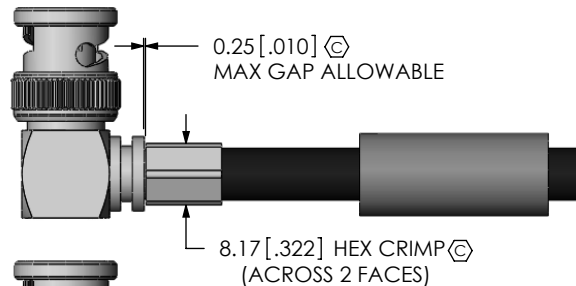

APPLY HEAT SHRINK TUBING

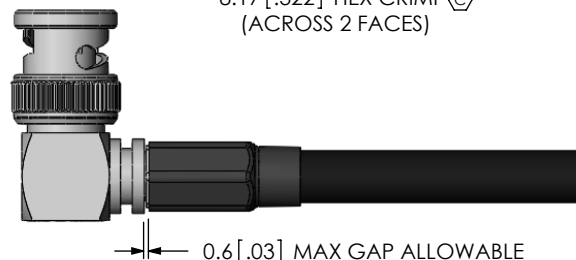

F:\DWG\MISC\MKTG\BNC7T-P-C-XX-RA-CA6-MKT.SLDRW

PROPRIETARY NOTE

THIS DOCUMENT CONTAINS INFORMATION CONFIDENTIAL AND PROPRIETARY TO SAMTEC, INC. AND SHALL NOT BE REPRODUCED OR TRANSFERRED TO OTHER DOCUMENTS OR DISCLOSED TO OTHERS OR USED FOR ANY PURPOSE OTHER THAN THAT WHICH IT WAS OBTAINED WITHOUT THE EXPRESSED WRITTEN CONSENT OF SAMTEC, INC.

DO NOT SCALE DRAWING

SHEET SCALE: 1:1



520 PARK EAST BLVD, NEW ALBANY, IN 47150
PHONE: 812-944-6733 FAX: 812-948-5047
e-Mail: info@SAMTEC.com code 55322

DESCRIPTION:
TRUE 75 OHM, BNC RA RG6 CABLE PLUG

DWG. NO.
BNC7T-P-C-XX-RA-CA6

BY: G. HERMAN 01/09/2009 SHEET 2 OF 2