

## Engineering Data

**D**  
**Rechargeable 1.2V**  
**Nickel-Cadmium**

### ENERGIZER NO. CH4

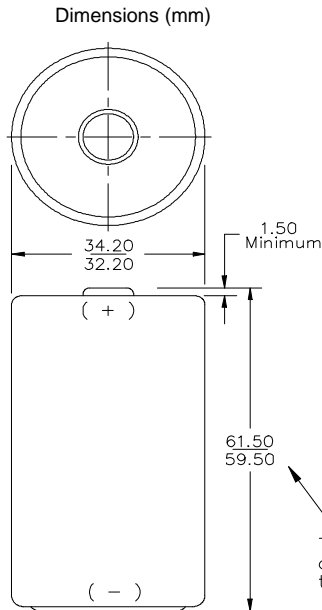

Millimeters	Inches
1.50	0.059
32.20	1.268
34.20	1.346
59.50	2.343
61.50	2.421

This dimension applies contact to contact

**Chemical System:** Nickel-Cadmium (NiCd)

**Designation:** ANSI / NEDA-10013HC, IEC-KR35/62

**Battery Voltage:** 1.2 Volts

**Average Weight:** 135 grams (4.7 oz.)

**Volume:** 51.0 cubic centimeters (3.1 cubic inch)

**Terminals:** Flat Contact

**Rated Capacity: (to 1.0 Volt):** 4 Ah

(Based on 800 mA (0.2C) discharge rate)

**Cell:** One "D" size

**Jacket:** Laminated Shrinkhose

#### Charge Rate vs. Charging Time

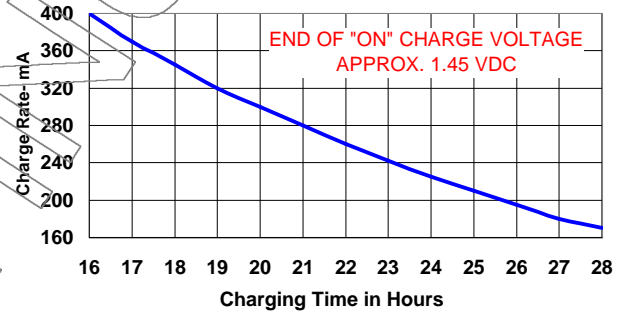

#### TYPICAL DISCHARGE CHARACTERISTICS Average Performance at 21°C (70°F)

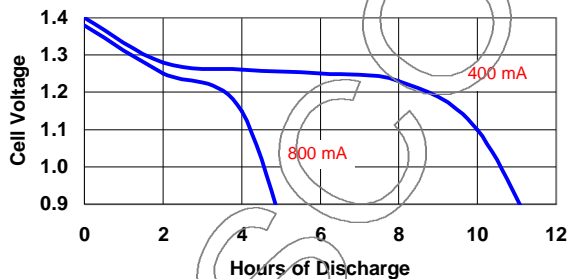

#### TYPICAL DISCHARGE CHARACTERISTICS Average Performance at 21°C (70°F)

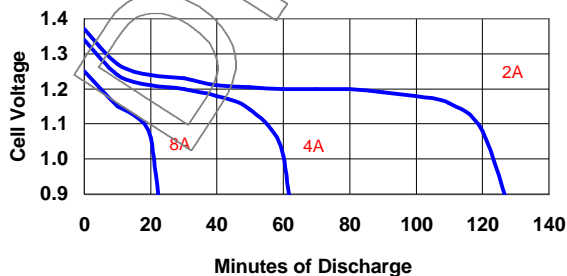

#### Charge Rate

Standard-charge batteries at 400 mA for 16 to 18 hours to reach full capacity.

Quick, Without Charge Control - charge batteries at 800 mA for 7-8 hours to reach full capacity.

Quick, Without Charge Control (timer)- charge batteries at 1600 mA for 3 hours, then switch to a lower rate (0.2C to 0.1C) to reach full capacity.

Trickle-charge batteries at 200 mA continuously to maintain a full state of charge.

Quick, Without Comments - To maintain a fully charged cell for standby service, charge at trickle rate. Cycle life will generally increase as the charge rate is reduced.

Charge rates significantly below 200 mA (0.05C) will not fully recharge a completely discharged cell.

#### Operating and Storage Temperatures

Ranges of temperature applicable to operation of the CH4 cells are:

**Charge @ 0.1C:** 32°F to 122°F (0°C to 50°C)

**Discharge @ 0.1C:** -4°F to 122°F (-20°C to 50°C)

**Storage:** -40°F to 140°F (-40°C to 60°C) (6 Months Max.)

-4°F to 95°F (-20°C to 35°C) (2 Years Max.)

Operating at extreme temperature will significantly effect service and cycle life.

#### Important Notice

This data sheet contains information specific to batteries manufactured at time of its publication. Please contact your Energizer representative for most current information. Contents herein do not constitute a warranty.