

### FEATURES

250MHz Bandwidth  
Monolithic Construction  
Low Noise Figure 4.7dB  
Excellent Detected Output Matching  
Direct Replacement for SL521/SL1521

### APPLICATIONS

Missile Guidance  
Electronic Warfare (ECM, ECCM, ESM)  
Miniturized LOG Strips  
Nuclear Instrumentation

### GENERAL DESCRIPTION

The AD9521 is a wideband amplifier stage with a logarithmic detected output. The high-performance bipolar process used to construct the AD9521 allows operation from 10MHz to 250MHz with minimal gain variation. The AD9521 is pin compatible with the SL521 and the SL1521.

The AD9521 is constructed in a well controlled monolithic process which provides very good gain tolerance ( $\pm 1.5\text{dB}$ ) over the full performance range. An added benefit of the high gain tolerance is a high degree of detected output current matching from device to device. The matching combined with the low 4dB noise figure allows the construction of 80dB to 90dB dynamic range LOG strips with better than  $\pm 1\text{dB}$  linearity.

The AD9521 is offered in two gain tolerance grades as both a commercial temperature range device, 0 to  $+70^\circ\text{C}$ , and as an extended temperature range device,  $-55^\circ\text{C}$  to  $+125^\circ\text{C}$ . All grades are available packaged in 8-pin TO-99 metal cans with the military grades also available packaged in ceramic LCC.

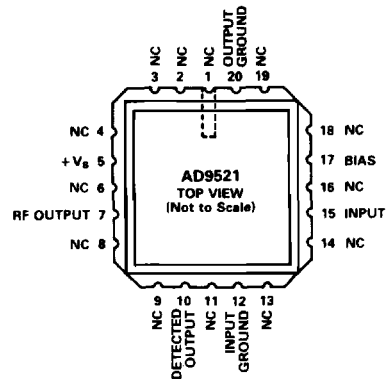
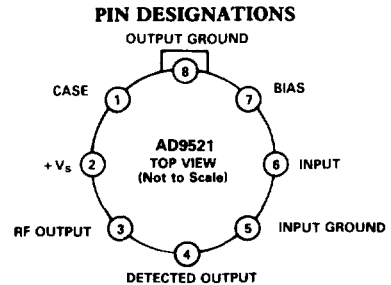

### ORDERING INFORMATION

| Device   | Detected Output Matching | Temperature Range                           | Description                      | Package Options* |
|----------|--------------------------|---|----------------------------------|------------------|
| AD9521JH | 0.2mA                    | 0 to $+70^\circ\text{C}$                    | 8-Pin Can, Industrial            | H-08A            |
| AD9521KH | 0.1mA                    | 0 to $+70^\circ\text{C}$                    | 8-Pin Can, Industrial            | H-08A            |
| AD9521SE | 0.2mA                    | $-55^\circ\text{C}$ to $+125^\circ\text{C}$ | 20-Pin LCC, Extended Temperature | E-20A            |
| AD9521SH | 0.2mA                    | $-55^\circ\text{C}$ to $+125^\circ\text{C}$ | 8-Pin Can, Extended Temperature  | H-08A            |
| AD9521TE | 0.1mA                    | $-55^\circ\text{C}$ to $+125^\circ\text{C}$ | 20-Pin LCC, Extended Temperature | E-20A            |
| AD9521TH | 0.1mA                    | $-55^\circ\text{C}$ to $+125^\circ\text{C}$ | 8-Pin Can, Extended Temperature  | H-08A            |

\*See Section 20 for package outline information.

# SPECIFICATIONS

## ABSOLUTE MAXIMUM RATINGS<sup>1</sup>

|                                       |          |
|---------------------------------------|----------|
| Supply Voltage (+V <sub>S</sub> )     | +9V      |
| Differential Voltage Between Grounds  | 0.5V     |
| Maximum Input Before Overload         | 1.9V rms |
| Instantaneous Voltage at the Detected |          |
| Video Output                          | 12V      |
| RF Output Current                     | 10mA     |
| Power Dissipation                     | 500mW    |

|  |                   |                 |
|--|-------------------|-----------------|
| Operating Temperature Range <sup>2</sup> | AD9521JH/KH       | 0 to +70°C      |
|  | AD9521SE/SH/TE/TH | -55°C to +125°C |
| Storage Temperature Range                |                   | -55°C to +150°C |
| Junction Temperature                     |                   | +175°C          |
| Lead Soldering Temperature (10sec)       |                   | +300°C          |

## ELECTRICAL CHARACTERISTICS (Supply Voltages = +6V; INPUT connected to BIAS pin; R<sub>S</sub> = 50Ω; C<sub>L</sub> ≤ 8pF, unless otherwise stated)

| Parameter   | Mil <sup>3</sup><br>Sub<br>Group | Temp  | Industrial Temp. Range<br>0 to +70°C |      |      |           |      |      | Military Temp. Range<br>-55°C to +125°C |      |      |             |      |      | Units            |
|---|----------------------------------|-------|--------------------------------------|------|------|-----------|------|------|---|------|------|-------------|------|------|------------------|
|   |                                  |       | AD9521JH                             |      |      | AD9521KH  |      |      | AD9521SE/SH                             |      |      | AD9521TE/TH |      |      |                  |
|   |                                  |       | Min                                  | Typ  | Max  | Min       | Typ  | Max  | Min                                     | Typ  | Max  | Min         | Typ  | Max  |                  |
| <b>AC PERFORMANCE</b>                             |                                  |       |                                      |      |      |           |      |      |   |      |      |             |      |      |                  |
| Voltage Gain (f <sub>IN</sub> = 30MHz)            | 7                                | +25°C | 11.5                                 | 12.2 | 12.5 | 11.5      | 12.2 | 12.5 | 11.5                                    | 12.2 | 12.5 | 11.5        | 12.2 | 12.5 | dB               |
|   | 8                                | Full  | 11.0                                 |      | 13.0 | 11.0      |      | 13.0 | 11.0                                    |      | 13.0 | 11.0        |      | 13.0 | dB               |
| Voltage Gain (f <sub>IN</sub> = 60MHz)            | 7                                | +25°C | 12.0                                 | 12.8 | 13.0 | 12.0      | 12.8 | 13.0 | 12.0                                    | 12.8 | 13.0 | 12.0        | 12.8 | 13.0 | dB               |
|   | 8                                | Full  | 11.7                                 |      | 13.7 | 11.7      |      | 13.7 | 11.7                                    |      | 13.7 | 11.7        |      | 13.7 | dB               |
| Voltage Gain (f <sub>IN</sub> = 120MHz)           | 7                                | +25°C | 12.2                                 | 13.0 | 13.8 | 12.2      | 13.0 | 13.8 | 12.2                                    | 13.0 | 13.8 | 12.2        | 13.0 | 13.8 | dB               |
|   | 8                                | Full  | 11.5                                 |      | 14.5 | 11.5      |      | 14.5 | 11.5                                    |      | 14.5 | 11.5        |      | 14.5 | dB               |
| Voltage Gain (f <sub>IN</sub> = 160MHz)           | 7                                | +25°C | 12.7                                 | 13.4 | 14.2 | 12.7      | 13.4 | 14.2 | 12.7                                    | 13.4 | 14.2 | 12.7        | 13.4 | 14.2 | dB               |
|   | 8                                | Full  | 11.5                                 |      | 14.5 | 11.5      |      | 14.5 | 11.5                                    |      | 14.5 | 11.5        |      | 14.5 | dB               |
| Input Capacitance                                 |                                  | +25°C | 6                                    |      |      | 6         |      |      | 6                                       |      |      | 6           |      |      | pF               |
| Noise Figure <sup>4</sup>                         | 12                               | +25°C | 4.7 4.9                              |      |      | 4.7 4.9   |      |      | 4.7 4.9                                 |      |      | 4.7 4.9     |      |      | dB               |
| Gain Variation vs. Temperature <sup>5</sup>       |                                  | Full  | 0.67                                 |      |      | 0.67      |      |      | 0.67                                    |      |      | 0.67        |      |      | dB               |
| Gain Variation vs. Supply <sup>6</sup>            | 7, 8                             |       | 0.74 1.15                            |      |      | 0.74 1.15 |      |      | 0.74 1.15                               |      |      | 0.74 1.15   |      |      | dB/V             |
| Frequency Response                                |                                  |       |                                      |      |      |           |      |      |   |      |      |             |      |      |                  |
| Upper Cutoff Frequency                            | 7                                | +25°C | 230                                  | 245  |      | 230       | 245  |      | 230                                     | 245  |      | 230         | 245  | MHz  |                  |
| Lower Cutoff Frequency                            | 8                                | Full  | 200                                  |      |      | 200       |      |      | 200                                     |      |      | 200         |      | MHz  |                  |
|   | 7, 8                             | Full  |                                      | 7    | 10   |           | 7    | 10   |   | 7    | 10   |             | 7    | 10   | MHz              |
| <b>DETECTED VIDEO OUTPUT</b>                      |                                  |       |                                      |      |      |           |      |      |   |      |      |             |      |      |                  |
| Output Current (@ 60MHz (Max)) <sup>7</sup>       | 7                                | +25°  | 0.90                                 | 1.02 | 1.10 | 0.95      | 1.02 | 1.05 | 0.90                                    | 1.02 | 1.10 | 0.95        | 1.02 | 1.05 | mA               |
|   | 8                                | Full  | 0.80                                 |      | 1.20 | 0.85      |      | 1.15 | 0.80                                    |      | 1.20 | 0.85        |      | 1.15 | mA               |
| (80% Input Level) <sup>8</sup>                    | 7                                | +25°C | 0.70                                 | 0.82 | 0.90 | 0.75      | 0.82 | 0.85 | 0.70                                    | 0.82 | 0.90 | 0.75        | 0.82 | 0.85 | mA               |
| (No Input) <sup>9</sup>                           | 7                                | +25°C | 0.02 0.04                            |      |      | 0.02 0.04 |      |      | 0.02 0.04                               |      |      | 0.02 0.04   |      |      | mA               |
| Output Current (@ 120MHz (Max)) <sup>7</sup>      | 7                                | +25°C | 0.51                                 | 0.70 | 0.90 | 0.62      | 0.70 | 0.85 | 0.51                                    | 0.70 | 0.90 | 0.62        | 0.70 | 0.85 | mA               |
|   | 8                                | Full  | 0.40                                 |      | 0.91 | 0.51      |      | 0.90 | 0.40                                    |      | 0.91 | 0.51        |      | 0.90 | mA               |
| (80% Input Level) <sup>8</sup>                    | 7                                | +25°C | 0.50                                 | 0.68 | 0.86 | 0.60      | 0.68 | 0.81 | 0.50                                    | 0.68 | 0.86 | 0.60        | 0.68 | 0.81 | mA               |
| (No Input) <sup>9</sup>                           | 7                                | +25°C | 0.02 0.04                            |      |      | 0.02 0.04 |      |      | 0.02 0.04                               |      |      | 0.02 0.04   |      |      | mA               |
| Detected Output Variation vs. Supply <sup>6</sup> | 7                                | +25°C | 28 30                                |      |      | 28 30     |      |      | 28 30                                   |      |      | 28 30       |      |      | %/V              |
| Detected Output vs. Temperature <sup>5</sup>      |                                  | Full  | 9                                    |      |      | 9         |      |      | 9                                       |      |      | 9           |      |      | %                |
| <b>RF OUTPUT<sup>5,7</sup></b>                    |                                  |       |                                      |      |      |           |      |      |   |      |      |             |      |      |                  |
| Maximum RF Output Voltage                         |                                  | +25°C | 1.6                                  |      |      | 1.6       |      |      | 1.6                                     |      |      | 1.6         |      |      | V <sub>p-p</sub> |
| RF Output Propagation Delay                       |                                  | +25°C | 1.4                                  |      |      | 1.4       |      |      | 1.4                                     |      |      | 1.4         |      |      | ns               |
| <b>POWER SUPPLY<sup>10</sup></b>                  |                                  |       |                                      |      |      |           |      |      |   |      |      |             |      |      |                  |
| Supply Current (+6.0V)                            | 1                                | +25°C | 14.0                                 | 16.0 |      | 14.0      | 16.0 |      | 14.0                                    | 16.0 |      | 14.0        | 16.0 | mA   |                  |
|   | 2, 3                             | Full  | 16.5                                 |      |      | 16.5      |      |      | 16.5                                    |      |      | 16.5        |      |      | mA               |
| Nominal Power Dissipation                         |                                  | +25°C | 84                                   |      |      | 84        |      |      | 84                                      |      |      | 84          |      |      | mW               |

### NOTES

<sup>1</sup>Absolute maximum ratings are limiting values, to be applied individually, and beyond which serviceability of the circuit may be impaired. Functional operation under any of these conditions is not necessarily implied.

Exposure to absolute maximum rating conditions for extended periods may affect device reliability.

<sup>2</sup>Typical thermal impedance . . .

AD9521 Metal Can θ<sub>JA</sub> = 185°C/W; θ<sub>JC</sub> = 50°C/W  
AD9521 LCC θ<sub>JA</sub> = 80°C/W; θ<sub>JC</sub> = 50°C/W.

<sup>3</sup>Military subgroups apply to military qualified devices only.

<sup>4</sup>R<sub>S</sub> = 450Ω; 60MHz.

<sup>5</sup>A<sub>IN</sub> = 60MHz.

<sup>6</sup>Measured at ±5% of +V<sub>S</sub>; A<sub>IN</sub> = 60MHz.

<sup>7</sup>Input = 0.5V rms.

<sup>8</sup>Input = 0.09V rms.

<sup>9</sup>Input = 0.0V rms.

<sup>10</sup>Supply voltage should remain stable within ±5% for normal operation.

Specifications subject to change without notice.

### EXPLANATION OF GROUP A MILITARY SUBGROUPS

|  |  |  |
|--|--|--|
| Subgroup 1 - Static tests at +25°C.                    | Subgroup 5 - Dynamic tests at max rated operating temp.            | Subgroup 9 - Switching tests at +25°C.                     |
| Subgroup 2 - Static tests at max rated operating temp. | Subgroup 6 - Dynamic tests at min rated operating temp.            | Subgroup 10 - Switching tests at max rated operating temp. |
| Subgroup 3 - Static tests at min rated operating temp. | Subgroup 7 - Functional tests at +25°C.                            | Subgroup 11 - Switching tests at min rated operating temp. |
| Subgroup 4 - Dynamic tests at +25°C.                   | Subgroup 8 - Functional tests at max and min rated operating temp. | Subgroup 12 - Periodically sample tested.                  |

FUNCTIONAL DESCRIPTION

| PIN NAME        | DESCRIPTION  |
|-----------------|--|
| CASE            | - Case connection for the TO-99 metal can package only.  |
| +V <sub>S</sub> | - Positive supply terminal, nominally +6.0V.   |
| RF OUTPUT       | - The RF OUTPUT is used to drive subsequent LOG detection stages. The RF OUTPUT level is roughly +12dB above the IF signal strength at the input.                                      |
| DETECTED OUTPUT | - The DETECTED OUTPUT provides a dc current logarithmically proportional to the IF signal level at the input.  |
| INPUT GROUND    | - Isolated input ground connection. The input and output grounds should be connected together near the AD9521.   |
| INPUT           | - IF signal input.   |
| BIAS            | - The BIAS connection is tied to the INPUT pin to provide an adequate biasing level between ac coupled stages. The bias connection should be omitted between direct dc coupled stages. |
| OUTPUT GROUND   | - Isolated output ground connection. The input and output grounds should be connected together near the AD9521.  |

SCHEMATIC

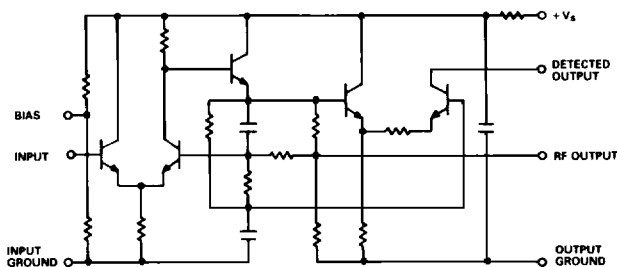

7

DIE LAYOUT AND MECHANICAL INFORMATION

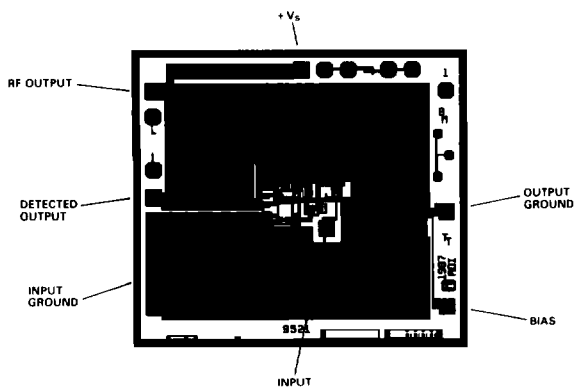

|                               |  |
|-------------------------------|--|
| Die Dimensions . . . . .      | 86 × 97 × 15 (± 2) mils  |
| Pad Dimensions . . . . .      | 4 × 4 mils   |
| Metalization . . . . .        | Aluminum   |
| Backing . . . . .             | None   |
| Substrate Potential . . . . . | -V <sub>S</sub>  |
| Passivation . . . . .         | Oxynitride   |
| Die Attach . . . . .          | Gold Eutectic  |
| Bond Wire . . . . .           | 1.25 mil Aluminum; Ultrasonic Bonding<br>or 1mil Gold; Gold Ball Bonding |

## TYPICAL LOG STRIP CONFIGURATION

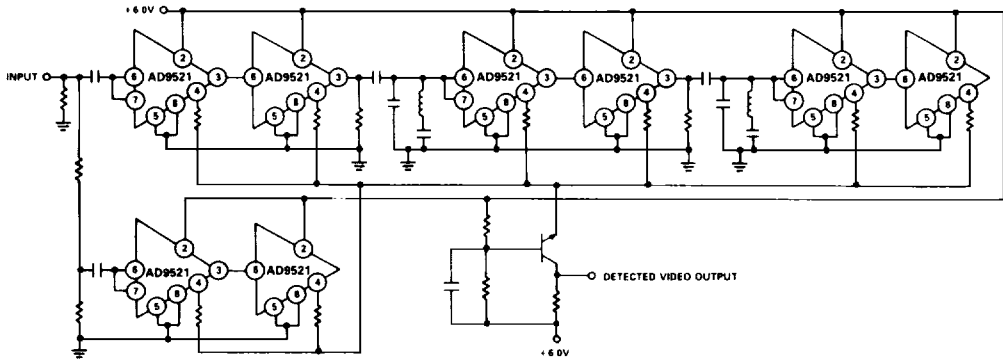

### APPLICATIONS INFORMATION

The AD9521 is primarily designed for use in successive detection LOG strips. The application circuit above, illustrates the typical configuration for one such design with roughly 90dB of dynamic range. In operation the IF input signal level is successively amplified by each stage in the upper chain. The IF signal at each stage generates a detected output current. The detected output current from each stage is summed in the common base follower stage at the end of the strip.

The key to the circuit is the limiting quality of the AD9521 logarithmic detected output. As the IF signal at each stage drives the detected output into saturation, the output current ceases to increase. In operation, the combined gain of all of the previous stages drives the last stage into saturation first. Any further increase in signal level will not increase the detected output level of the last stage, but all of the previous stages will enter saturation one-by-one as the signal level increases.

The limiting factor to the number of stages that can be combined is the input noise level. When the gain of the entire strip is sufficient to drive the last stage into saturation on the input noise of the first stage alone, further extensions of the strip will not increase the dynamic input range.

There are, however, two methods of increasing the dynamic range of the LOG strip which include bandwidth reduction and parallel strip configurations. The dynamic range can be extended by 20dB or more by incorporating a parallel log strip with an attenuated input. The main strip functions as before, but the

second strip, because of the attenuation, only contributes to the output for signals in excess of the main strip saturation level. The ultimate limitation is the maximum input signal level which the main strip will tolerate. Any further signal level increases could damage the input stage of the AD9521. This should not be a major problem since with this technique the dynamic range of the total strip can be as high as 100dB.

The dynamic range can also be increased by reducing the bandwidth of the strip itself. The noise voltage is directly proportional to the square root of the circuit bandwidth. This means that large operating bandwidths produce large amounts of noise which translates into limited dynamic range. The AD9521 is a particularly low-noise device, but even it can benefit from bandwidth reduction which has been incorporated into the circuit above. The two interstage filters limit the noise to a smaller region of frequencies and thereby allow the strip to be extended further.

Because of the high-frequency nature of the AD9521, several guidelines should be followed to insure optimum performance. The first is the use of an adequate low impedance ground plane. Just as important is the use of power supply decoupling capacitors to prevent signal feedthrough on the supply lines. Chip capacitors are highly recommended because of their reduced lead inductance. Sockets are not likely to produce the best results because of the interlead capacitance, but if they must be used, pin sockets are preferred.