

SMT CURRENT SENSE TRANSFORMERS

Ruggedized



- ⊗ Height: 10.2mm Max
- ⊗ Footprint: 19.9mm x 14.5mm Max
- ⊗ Current Rating: up to 35A
- ⊗ Frequency Range: 50kHz to 500kHz
- ⊗ Moisture Sensitivity Level: 1

Electrical Specifications @ 25 °C – Operating Temperature – 55 °C to +125 °C

Part 5,6 Number	Turns Ratio	Secondary Inductance (mH MIN)	DCR (mW MAX)		Hipot (VRMS)
			Primary	(11-12) Secondary (2-4)	
PL1839	50:1	1.4	0.42	700	1800
PL1808	100:1	5.6	0.42	1400	1800
PL1840	200:1	22.4	0.42	2900	1800

- NOTES:
- The temperature of the component (ambient temperature plus temperature rise) must be within the specified operating temperature range.
 - The maximum current rating is based upon temperature rise of the component and represents the DC current which will cause a typical temperature rise of 40°C with no airflow.
 - To calculate the value of the terminating resistor (Rt) use the following formula: $R_t (W) = V_{REF} * N / (I_{peak_primary})$
 - The peak flux density of the device must remain below 2000 Gauss. To calculate the peak flux density for a uni-polar current use the following formula: $BPK = 8.0 * V_{REF} * (Duty_Cycle_Max) * 105 / (N * Freq_kHz)$ * for bi-polar current applications divide BPK as calculated above by 2.
 - Optional Tape & Reel packaging can be ordered by adding a "T" suffix to the part number (i.e. PL1839 becomes **PL1839T**).

Mechanical

Electrical Schematic

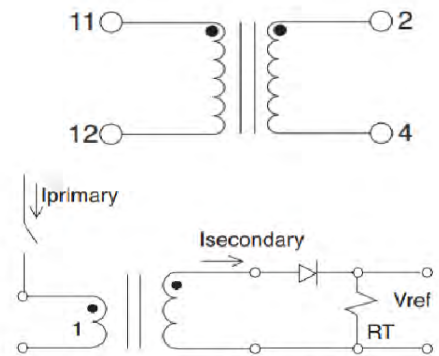
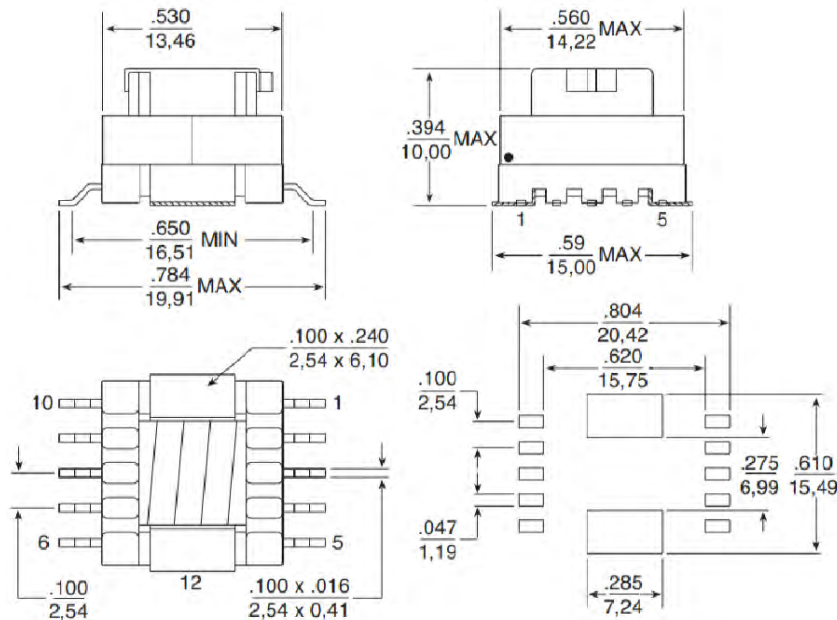

APPLICATION CIRCUIT

- Weight4.7 grams
- Tray100/tray
- Tape & Reel300/reel
- Coplanarity0.006 inches

Dimensions: $\frac{\text{Inches}}{\text{mm}}$

Unless otherwise specified, all tolerances are: $\pm \frac{.010}{0.25}$



Tin/Lead Recommended Reflow Profile (Based on J-STD-020D)

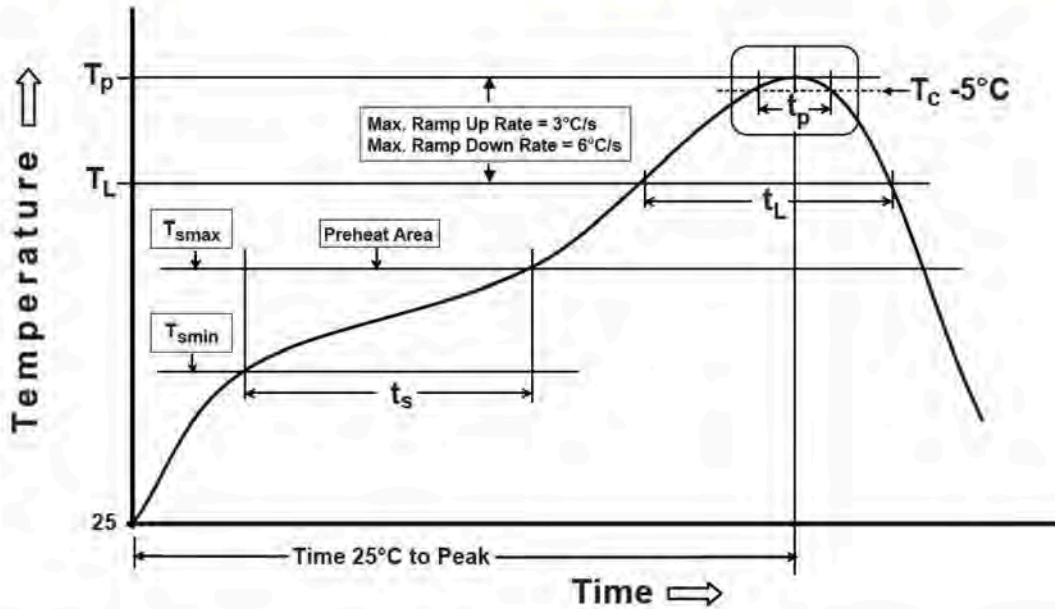

T _{SMIN} (°C)	T _{SMAX} (°C)	T _L (°C)	T _P (°C MAX)	t _s (s)	t _L (s)	t _p (s MAX)	Ramp-up rate (T _L to T _P)	Ramp-down rate (T _P to T _L)	Time 25°C to peak temperature (s MAX)
100	150	183	235	60-120	60-150	20	3°C/s MAX	6°C/s MAX	360

Notes:

1. All temperatures measured on the package leads.
2. Maximum times of reflow cycle: 2.

For More Information

iNRCORE, LLC
 311 Sinclair Road Bristol,
 PA 19007-6812 U.S.A
 Tel: + 1.215.781.6400
 Fax: +1.215.7816430

Global Sales Representatives and Locations:
<http://www.inrcore.com>

Performance warranty of products offered on this data sheet is limited to the parameters specified. Data is subject to change without notice. Other brand and product names mentioned herein may be trademarks or registered trademarks of their respective owners. © Copyright, 2020. iNRCORE, LLC. All rights reserved.

