

MITSUBISHI RF POWER TRANSISTOR

2SC730

NPN EPITAXIAL PLANAR TYPE

DESCRIPTION

2SC730 is a silicon NPN epitaxial planar type transistor designed for industrial use RF power amplifiers on VHF band mobile radio applications.

FEATURES

- High power gain: $G_{pe} \geq 10\text{dB}$
@ $V_{CC} = 13.5\text{V}$, $P_o = 1\text{W}$, $f = 150\text{MHz}$
- TO-39 metal sealed package for high reliability.
- All electrodes are isolated from the case.
- Equivalent input/output series impedance:
 $Z_{in} = 8 - j12 \Omega$ @ $P_o = 1\text{W}$, $V_{CC} = 13.5\text{V}$, $f = 175\text{MHz}$
 $Z_{out} = 41 - j68 \Omega$

APPLICATION

0.5 to 0.8 watt power amplifiers, and driver stage in VHF band.

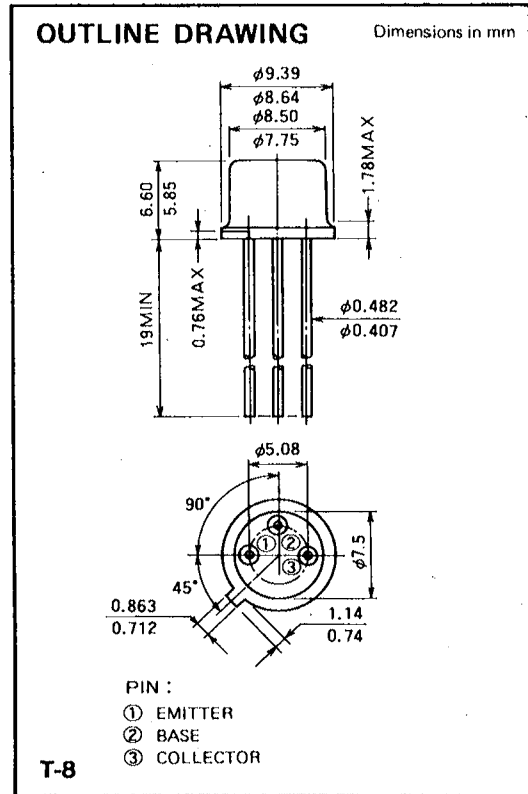

ABSOLUTE MAXIMUM RATINGS ($T_C = 25^\circ\text{C}$ unless otherwise specified)

Symbol	Parameter	Conditions	Ratings	Unit
V_{CBO}	Collector to base voltage		40	V
V_{EBO}	Emitter to base voltage		4	V
V_{CER}	Collector to emitter voltage	$R_{BE} = 10 \Omega$	40	V
I_C	Collector current		0.4	A
P_C	Collector dissipation	$T_a = 25^\circ\text{C}$	1.03	W
		$T_C = 25^\circ\text{C}$	3	W
T_j	Junction temperature		175	$^\circ\text{C}$
T_{stg}	Storage temperature		-65 to 175	$^\circ\text{C}$
R_{th-a}	Thermal resistance	Junction to ambient	145	$^\circ\text{C}/\text{W}$
R_{th-c}		Junction to case	50	$^\circ\text{C}/\text{W}$

Note. Above parameters are guaranteed independently.

ELECTRICAL CHARACTERISTICS ($T_C = 25^\circ\text{C}$ unless otherwise specified)

Symbol	Parameter	Test conditions	Limits			Unit
			Min	Typ	Max	
$V_{(BR)EBO}$	Emitter to base breakdown voltage	$I_E = 1\text{mA}$, $I_C = 0$	4			V
$V_{(BR)CBO}$	Collector to base breakdown voltage	$I_C = 1\text{mA}$, $I_E = 0$	40			V
$V_{(BR)CER}$	Collector to emitter breakdown voltage	$I_C = 10\text{mA}$, $R_{BE} = 10 \Omega$	40			V
I_{CBO}	Collector cutoff current	$V_{CB} = 15\text{V}$, $I_E = 0$			10	μA
I_{EBO}	Emitter cutoff current	$V_{EB} = 2.5\text{V}$, $I_C = 0$			100	μA
h_{FE}	DC forward current gain*	$V_{CE} = 10\text{V}$, $I_C = 0.1\text{A}$	10	50	180	—
P_O	Output power	$V_{CC} = 13.5\text{V}$, $P_{in} = 0.1\text{W}$, $f = 150\text{MHz}$	1	1.5		W
η_C	Collector efficiency		50	60		%

Note. * Pulse test, $P_W = 150\mu\text{s}$, duty = 5%.

Above parameters, ratings, limits and conditions are subject to change.

TEST CIRCUIT

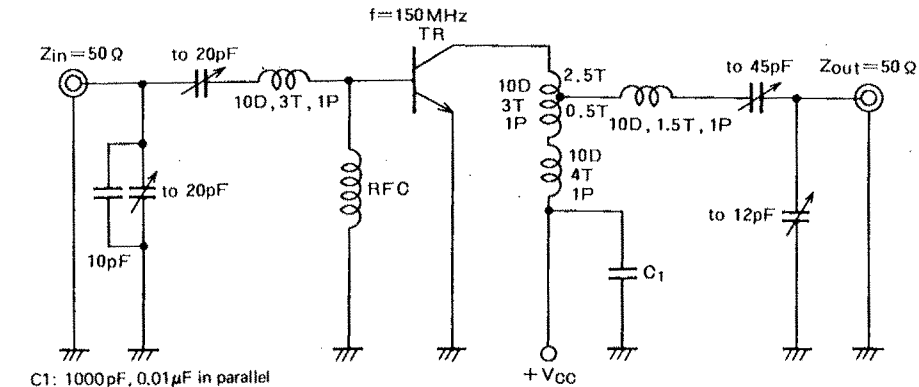

C1: 1000pF, 0.01μF in parallel
 Notes: All coils are made from 1.5mm silver plated copper wire
 Coil dimensions in milli-meter
 D: Inner diameter of coil
 T: Turn number of coil
 P: Pitch of coil

TYPICAL PERFORMANCE DATA

COLLECTOR DISSIPATION VS. AMBIENT TEMPERATURE

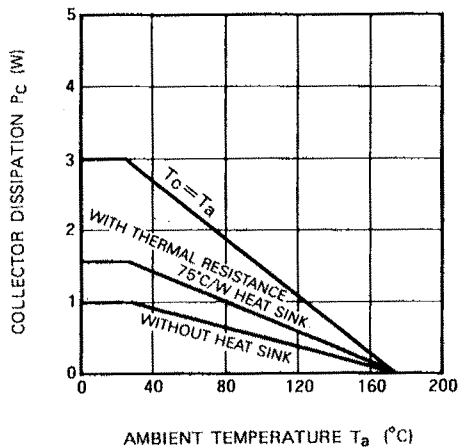

THERMAL RESISTANCE 75°C HEAT SINK DRAWING

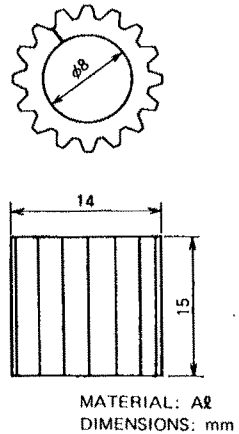

COLLECTOR CURRENT VS. COLLECTOR TO EMITTER VOLTAGE

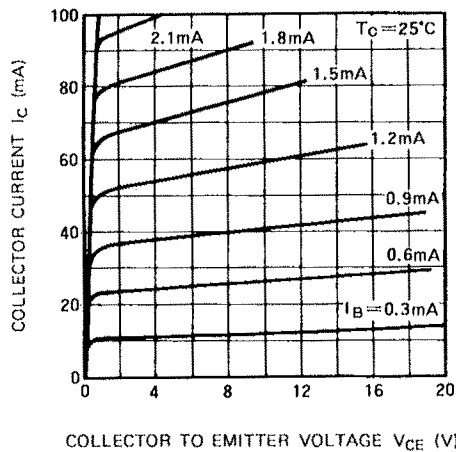

DC CURRENT GAIN VS. COLLECTOR CURRENT

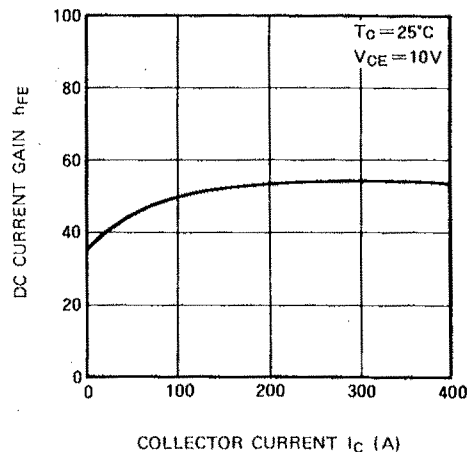

MITSUBISHI RF POWER TRANSISTOR
2SC730

NPN EPITAXIAL PLANAR TYPE

COLLECTOR TO EMITTER BREAKDOWN VOLTAGE VS. BASE TO EMITTER RESISTANCE

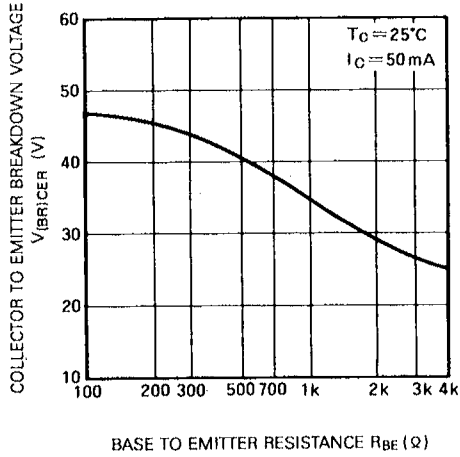

COLLECTOR OUTPUT CAPACITANCE VS. COLLECTOR TO BASE VOLTAGE

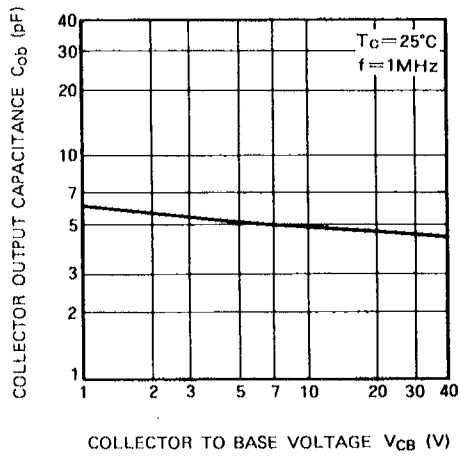

OUTPUT POWER, COLLECTOR EFFICIENCY VS. INPUT POWER

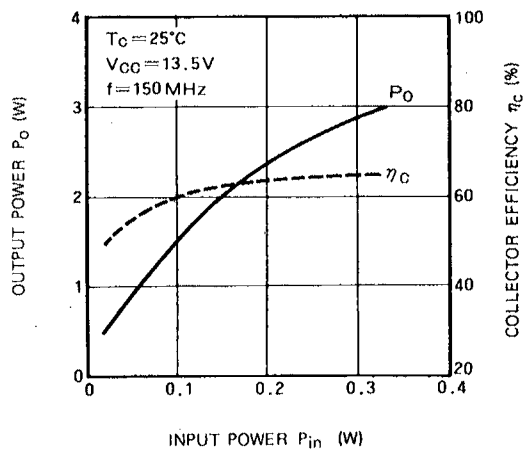

OUTPUT POWER VS. COLLECTOR SUPPLY VOLTAGE

