

NOTES: UNLESS OTHERWISE SPECIFIED

1. MATERIAL SPECIFICATIONS:
 BODY & NUT: BRASS PER ASTM B16.
 CONTACT: COPPER ALLOY.
 INSULATOR: TEFLON PER ASTM D1710.
2. FINISH SPECIFICATIONS:
 BODY: .000015 MIN GOLD PER ASTM B488 OVER .000080 MIN NICKEL PER AMS-QQ-N-290.
 CONTACT: .000030 MIN GOLD PER ASTM B488 OVER .000080 MIN NICKEL PER AMS-QQ-N-290.
 NUT: .000100 MIN NICKEL PER AMS-QQ-N-290 OVER COPPER FLASH PER ASTM B734.
3. ELECTRICAL SPECIFICATIONS:
 IMPEDANCE: 75 OHMS.
 FREQUENCY RANGE: DC-4.5GHZ.
 RETURN LOSS (ON MID-LAYER OF 2.4mm PCB): <-15dB UP TO 3.0GHZ, <-10dB UP TO 4.5 GHz.
4. COMPLIANT TO SMPTE 424M (3G-SDI) STANDARD.
5. INTERFACE PER CECC 22230.

REV	DESCRIPTION	BY DATE	APPD
F	REVISED PER ECR-ER28303	11/03/10 CY	CJC

P/N	DESCRIPTION	QTY
034B-060-00401H	SINGLE PACK	1
034B-060-00401HU	BULK PACK	600

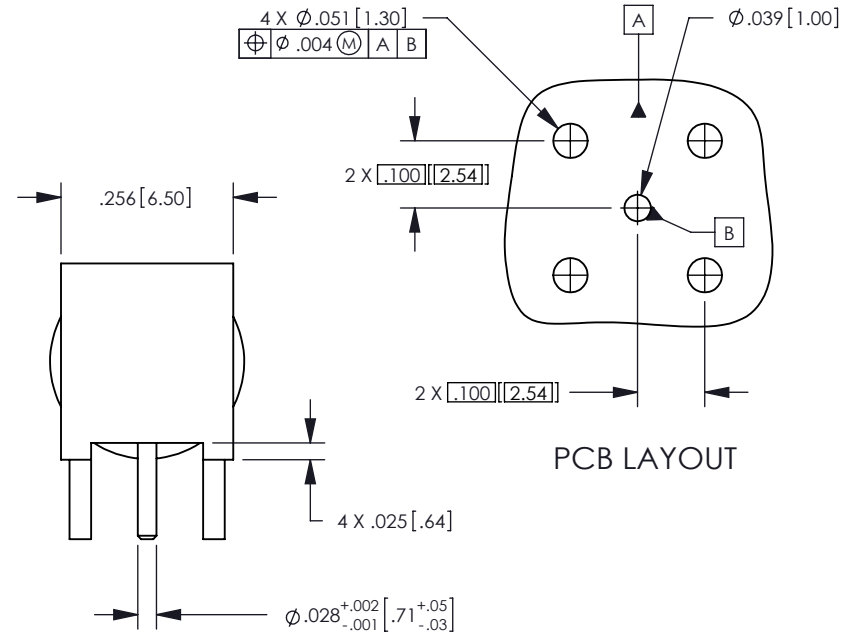
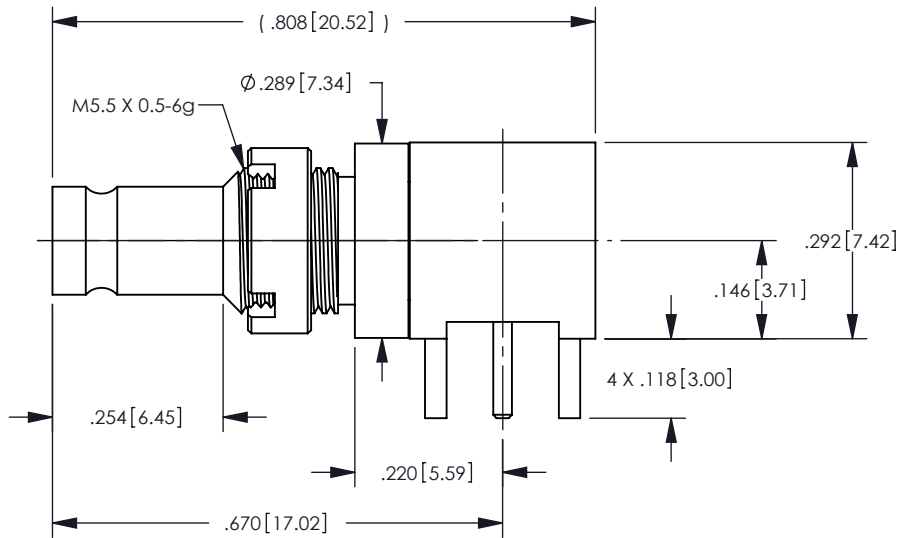

PCB LAYOUT

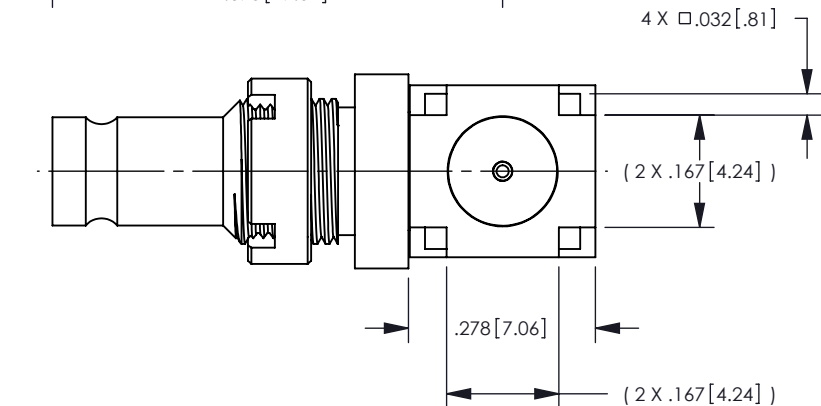

CATALOG P/N: 034B-060-00401H

PER ASME Y14.5M-1994 UNLESS OTHERWISE SPECIFIED: DIMENSIONS ARE IN INCHES [MM] TOLERANCES: DECIMAL: .XX [X.X] ± .01 [0.3] .XXX [X.XX] ± .005 [0.13] .XXXX [X.XXX] ± .XXXX ANGLES: ± 2° SCALE: 3.5:1				 by WINCHESTER ELECTRONICS Winchester Electronics Corporation 62 Barnes Industrial Road North Wallingford, Connecticut 06492			
CUSTOMER DRAWING			THIRD ANGLE				
DRAWN DW		DATE 04/29/08		APPROVED Dcam		DATE 05/07/08	
APPROVED WPM		DATE 05/09/08		APPROVED XXX		DATE XX/XX/XX	
A SD034B-060-00401H				SHT OF REV 1 1 F			