

T-41-07

HL 1341A/AC/FG/MF/BF/DL

InGaAsP LD

HITACHI/(OPTOELECTRONICS) 54E D ■ 4496205 0012124 453 ■ HIT4

The HL1341A/AC/FG/MF/BF/DL are 1.3 μm InGaAsP distributed feedback (DFB) laser diodes with buried hetero structure. They are suitable as light sources in high-bit-rate long distance fiber optic communications and various other types of optical equipment.

Fiber Specifications (BF, DL only)

- Mode field diameter : 10.0 ± 1.0 μm
- Cutoff wavelength : 1.10 to 1.20 μm
- Core diameter : 10 μm
- External diameter : 125 μm
- Jacket diameter : 900 μm
- Fiber length : More than 500 mm

Features

- Long wavelength oscillation:
λ_p = 1290 to 1330 nm
- Room temperature 5 mW CW operation (A/AC/FG/MF)
- High output: P_f = 1.0 mW (CW, pulse operation) (BF/DL)
- Dynamic single mode to side mode ratio Sr = 35 dB (typ)
- Built-in monitor photo diode (FG/MF/BF/DL)
- High speed pulse response:
t_r, t_f ≤ 0.5 ns (A/AC/FG/MF)

Absolute Maximum Ratings (T_C = 25°C)

Item		Symbol	Rated Value	Units
Optical output power	HL1341A/AC/FG/MF	P _O	5	mW
Fiber optical output power	HL1341BF/DL	P _f	1.0	mW
Reverse voltage	HL1341A/AC	V _R	2	V
LD reverse voltage	HL1341FG/MF/BF/DL	V _{R(LD)}	2	V
PD reverse voltage		V _{R(PD)}	15	V
PD forward current		I _{F(PD)}	1	mA
Cooling current	HL1341BF/DL	I _C	1.4	A
Operating temperature		T _{opr}	0 to + 60	°C
Storage temperature	HL1341A/AC	T _{stg}	0 to + 80	°C
	HL1341FG/MF		- 40 to + 80	
	HL1341BF/DL		- 40 to + 70	

HL1341A/AC/FG/MF/BF/DL**Electrical and Optical Characteristics (T_C = 25°C)**

T-41-07

Item		Symbol	Min	Typ	Max	Units	Test Conditions
Threshold current	HL1341A/AC/FG/MF	I_{th}	—	25	50	mA	
	HL1341BF/DL		—	30	50		
Optical output power	HL1341A/AC/FG/MF	P_O	5	—	—	mW	Kink free
			2.5	—	—		$I_F = I_{th} + 20 \text{ mA}$
Fiber optical output power	HL1341BF/DL	P_f	1	—	—	mW	Kink free
			0.5	—	—		$I_F = I_{th} + 20 \text{ mA}$
Monitor output	HL1341A/AC	P_m	1	—	—	mW	$I_F = I_{th} + 20 \text{ mA}$
Lasing Wave-length	HL1341A/AC/FG/MF	λ_p	1290	1310	1330	nm	$P_O = 3 \text{ mW}$
	HL1341BF/DL						$P_f = 0.5 \text{ mW}$
Side mode suppression ratio	HL1341A/AC/FG/MF	S_r	30	35	—	dB	$P_O = 3 \text{ mW}$
	HL1341BF/DL						$P_f = 0.5 \text{ mW, CW}$
Beam divergence (parallel)	HL1341A/AC/FG/MF	$\theta_{//}$	—	30	—	deg.	$P_O = 3 \text{ mW, FWHM}$
Beam divergence (perpendicular)	HL1341A/AC/FG/MF	θ_{\perp}	—	40	—	deg.	$P_O = 3 \text{ mW, FWHM}$
Rise time	HL1341A/AC/FG/MF	t_r	—	—	0.5	ns	$I_{bias} = I_{th}, 10 \text{ to } 90 \%$
	HL1341BF/DL			—	0.2	—	$I_{bias} = I_{th}, 10 \text{ to } 90 \%$
Fall time	HL1341A/AC/FG/MF	t_f	—	—	0.5	ns	$I_{bias} = I_{th}, 90 \text{ to } 10 \%$
	HL1341BF/DL			—	0.3	—	$I_{bias} = I_{th}, 90 \text{ to } 10 \%$
PD dark current	HL1341FG/MF/BF/DL	I_{DARK}	—	—	350	nA	$V_{R(PD)} = 5 \text{ V}$
Monitor current	HL1341FG/MF	I_S	50	—	—	μA	$V_{R(PD)} = 5 \text{ V, } P_O = 3 \text{ mW}$
	HL1341BF/DL			300	—	—	$V_{R(PD)} = 5 \text{ V, } P_f = 0.5 \text{ mW}$
PD capacitance	HL1341FG/MF/BF/DL	C_t	—	10	20	pF	$V_{R(PD)} = 5 \text{ V, } f = 1 \text{ MHz}$
Photosensitivity saturation bias voltage	HL1341FG/MF/BF/DL	$V_{R(S)}$	—	—	2	V	
Cooling capacity	HL1341BF/DL	ΔT	40	—	—	°C	$P_f = 0.5 \text{ mW, } T_O = 60^\circ\text{C}$
Cooling current		I_C	—	—	1.4	A	$\Delta T = 40^\circ\text{C}$
Cooling voltage			—	—	1.8	V	$\Delta T = 40^\circ\text{C}$
Thermistor resistance			—	10	—	K Ω	

HL1341A/AC/FG/MF/BF/DL

Internal Circuit

T-41-07

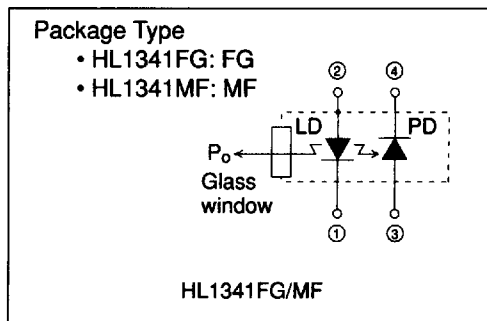
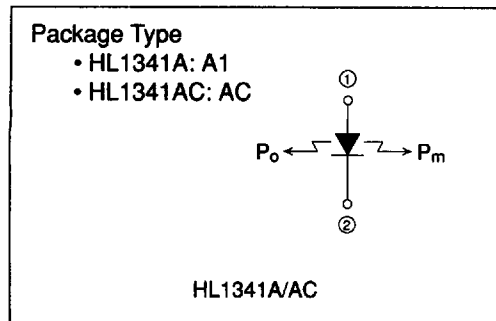

Pin Connections (Bottom view)

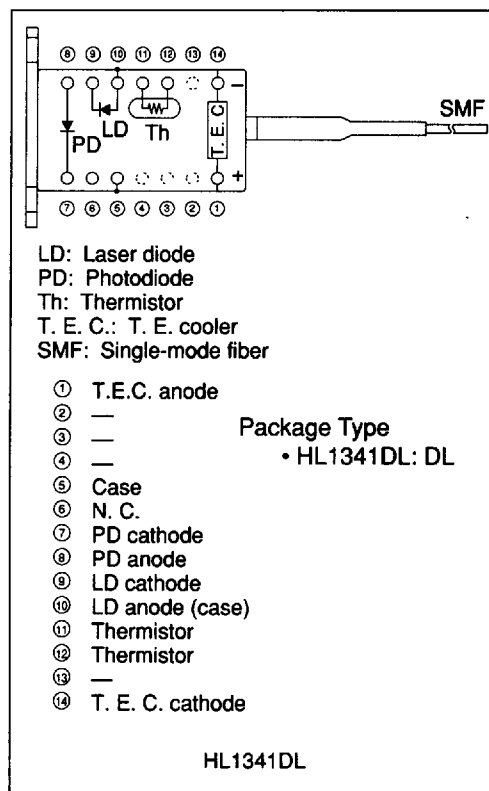
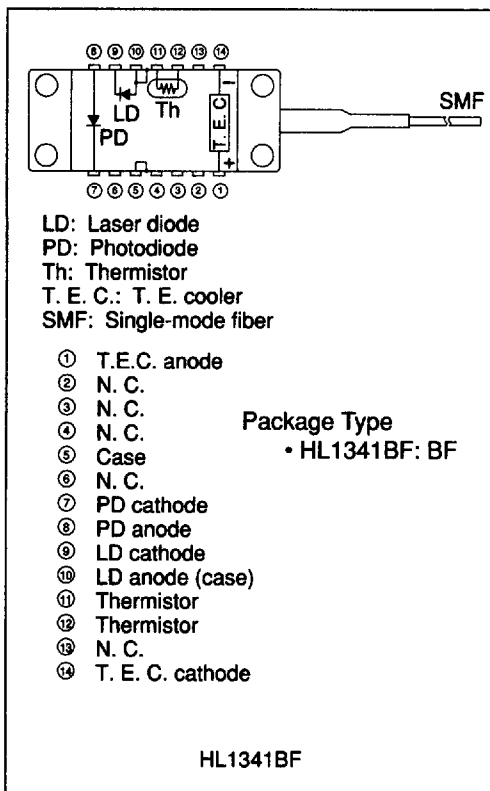

HL1341A/AC/FG/MF/BF/DL

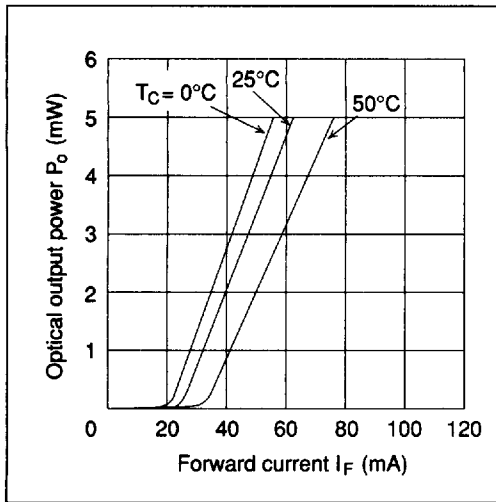

Figure 1 Optical Output Power vs. Forward Current (HL1341A, AC, FG,)

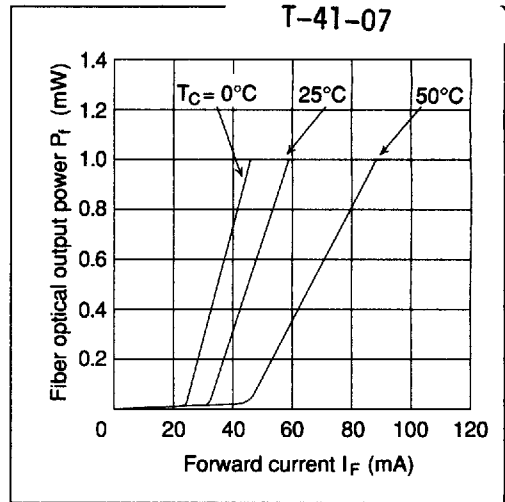

Figure 2 Optical Output Power vs. Forward Current (HL1341BF, DL)

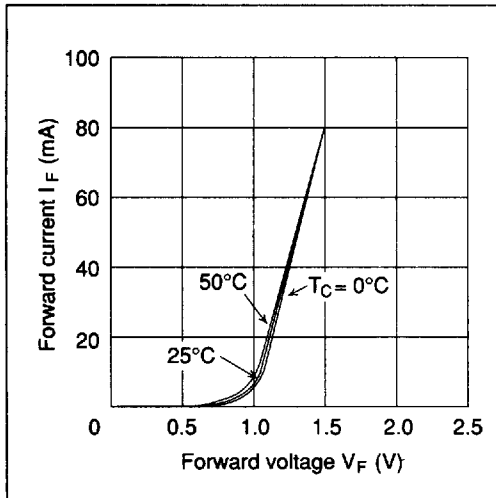

Figure 3 Forward Current vs. Forward Voltage

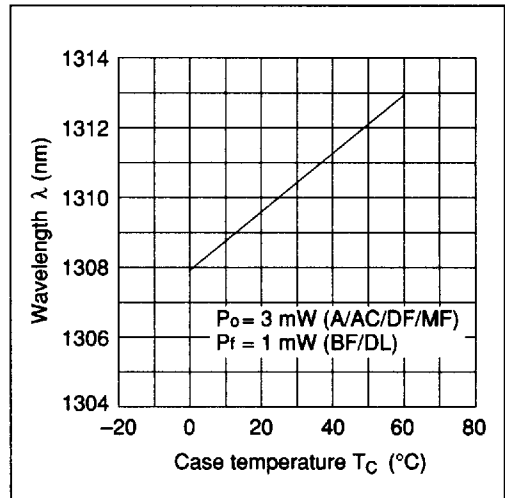

Figure 4 Lasing Wavelength Temperature Voltage

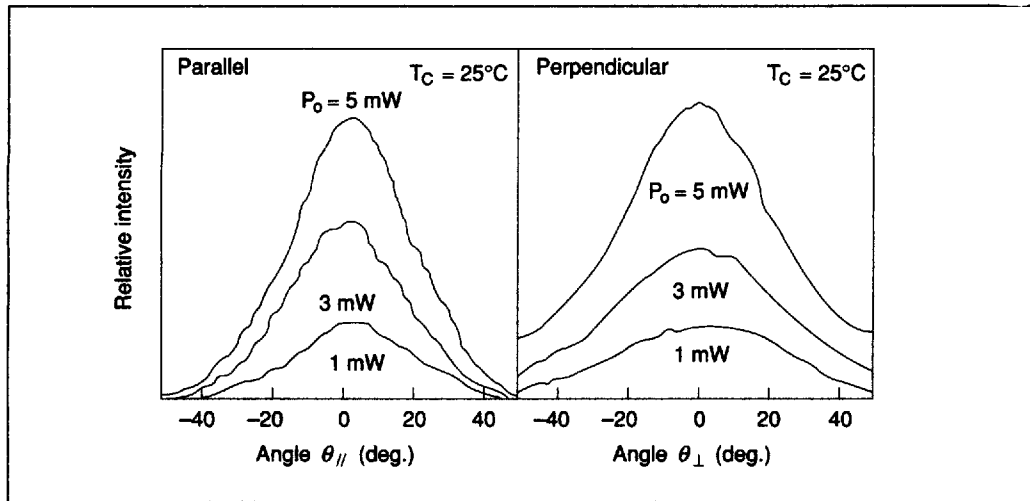

Figure 5 Far Field Pattern (HL1341A, AC, FG)

HL1341A/AC/FG/MF/BF/DL

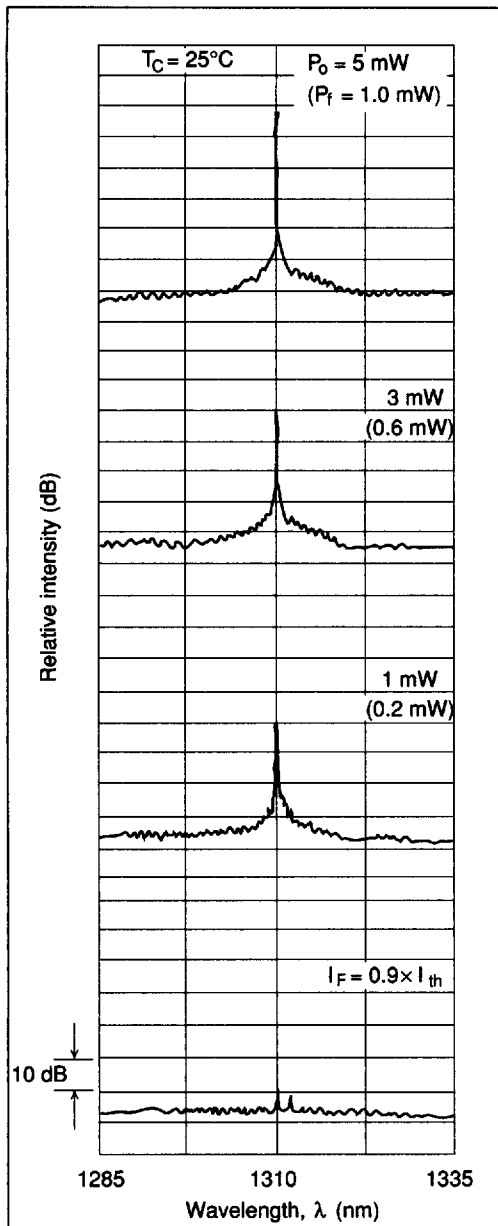

Figure 6 Output Power Dependence of Lasing Spectrum
(): HL1341BF/DL

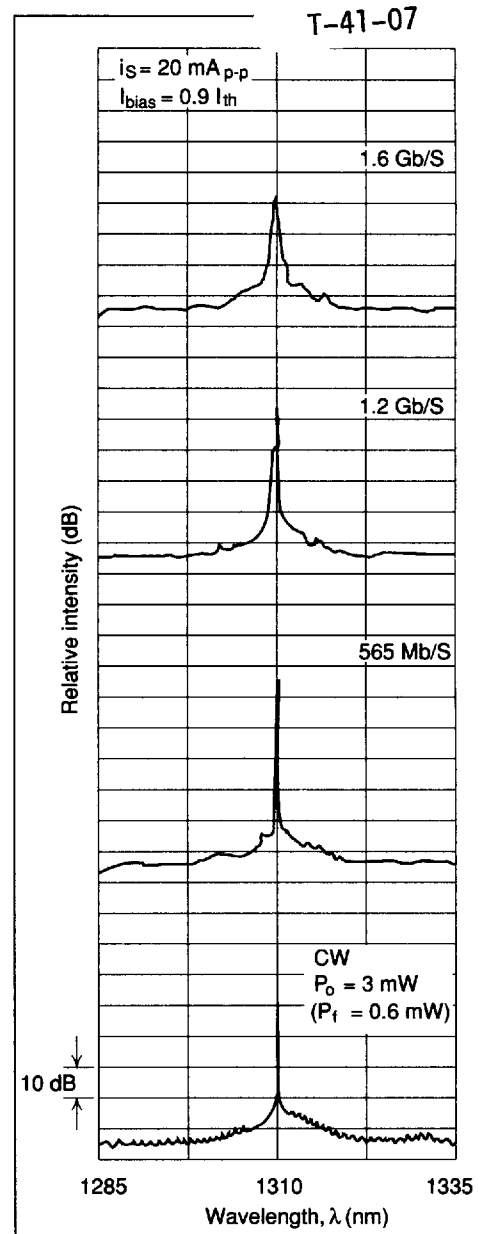

Figure 7 Frequency Dependence of Lasing Spectrum
(): HL1341BF/DL

HL1341A/AC/FG/MF/BF/DL

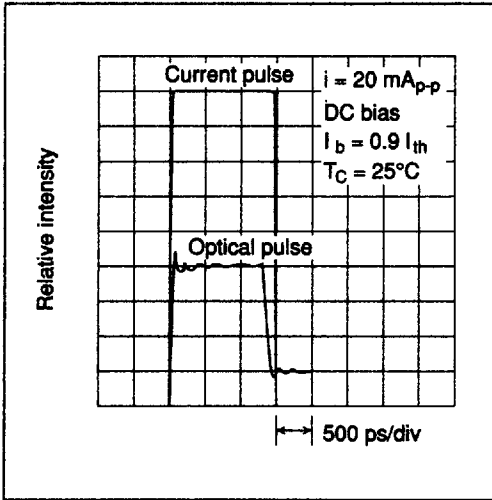

Figure 8 Pulse Response Characteristics (LD)

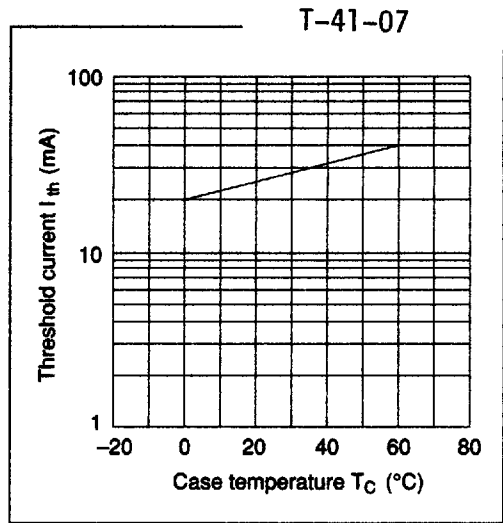

Figure 9 Threshold Current vs. Case Temperature

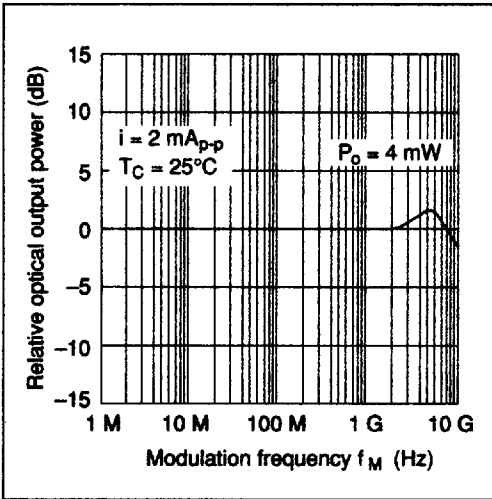

Figure 10 Frequency Response Characteristics (HL1341A, AC, FG)

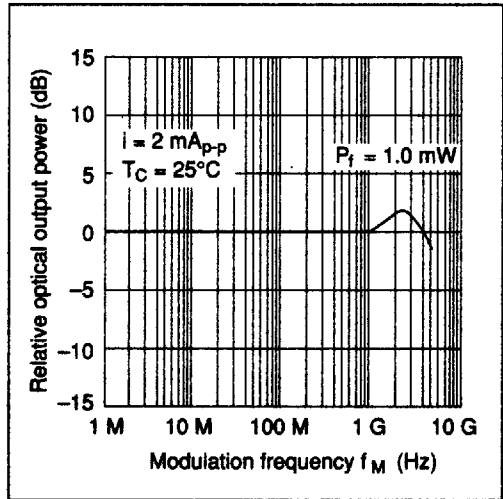

Figure 11 Frequency Response Characteristics (HL1341BF)

HL1341A/AC/FG/MF/BF/DL

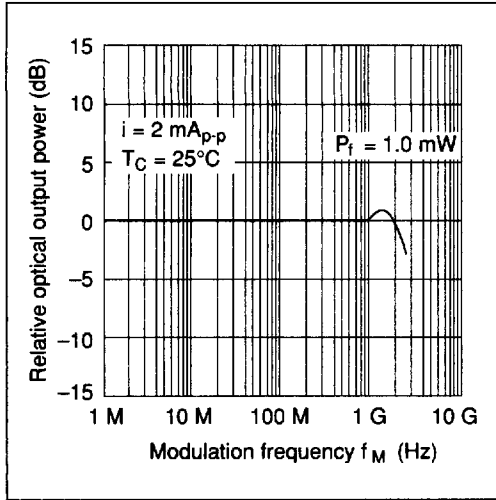

Figure 12 Frequency Response Characteristics (HL1341DL)

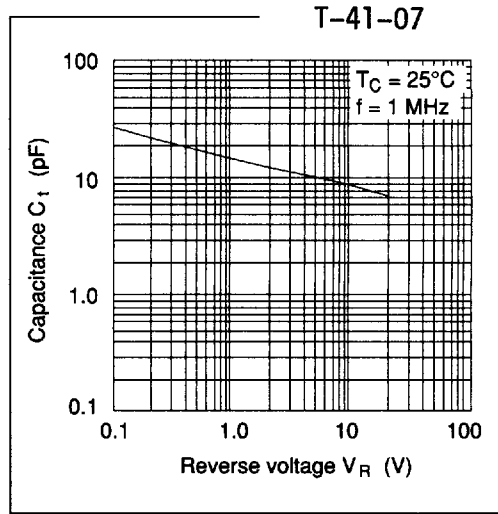

Figure 13 Capacitance vs. Reverse Voltage (PD) (HL1341BF, FG, DL)

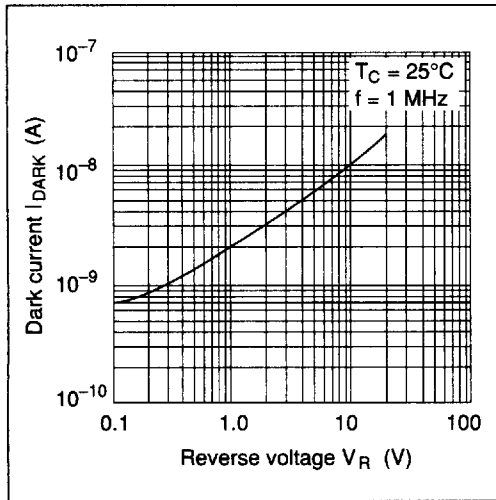

Figure 14 Dark Current vs. Reverse Voltage (HL1341BF, FG, DL)

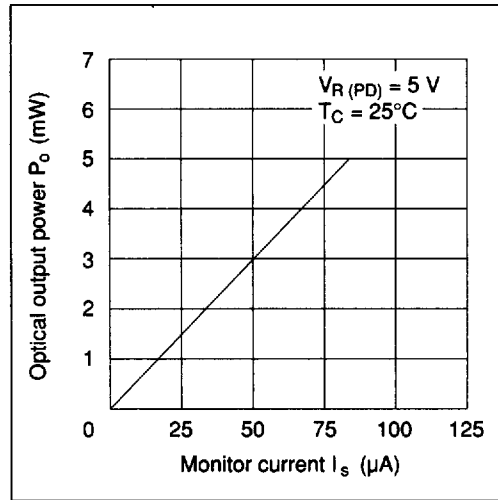

Figure 15 Optical Output Power vs. Monitor Current (HL1341FG)

HL1341A/AC/FG/MF/BF/DL

T-41-07

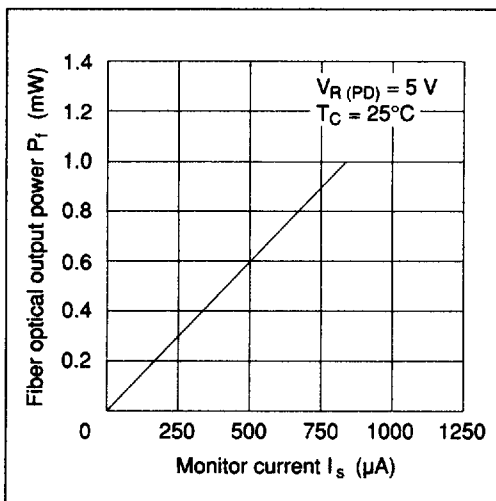

Figure 16 Fiber Optical Output Power vs. Monitor Current (HL1341BF, DL)

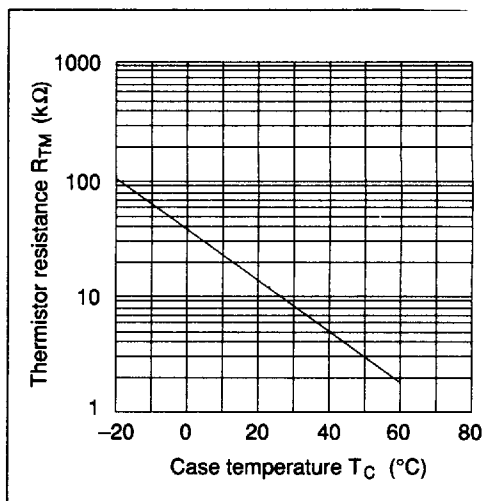

Figure 17 Thermistor Resistance vs. Case Temperature (HL1341BF, DL)

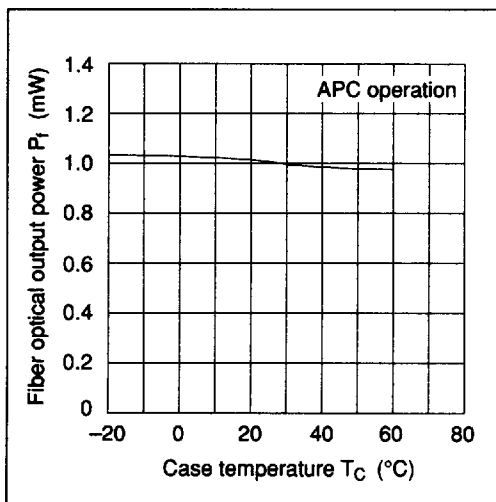

Figure 18 Tracking Characteristics (HL1341BF, DL)