

SG800(FXF, GXH)21

GATE TURN-OFF THYRISTOR

TENTATIVE DATA

CHOPPER, INVERTER APPLICATION

- . Repetitive Peak Off-State Voltage : $V_{DRM}=3300, 4500V$
- . Repetitive Peak Reverse Voltage : $V_{RRM}=3000, 4000V$
- . R.M.S On-State Current : $I_T(RMS)=300A$
- . Peak Turn-Off Current : $I_{TGQM}=800A$
- . Critical Rate of Rise of On-State Current : $di/dt=200A/\mu s$
- . Critical Rate of Rise of Off-State Voltage : $dv/dt=900V/\mu s$

MAXIMUM RATINGS

CHARACTERISTIC		SYMBOL	RATING	UNIT
Repetitive Peak Off-State Voltage	SG800FXF21	V_{DRM}	3300	V
	SG800GXH21		4500	
Repetitive Peak Reverse Voltage	SG800FXF21	V_{RRM}	3000	V
	SG800GXH21		4000	
Peak Turn-Off Current (Note 1)		I_{TGQM}	800	A
R.M.S On-State Current (Note 2)		$I_T(RMS)$	300	A
Peak One Cycle Surge On-State Current (Non-Repetitive)		I_{TSM}	4000(50Hz)	A
			4500(60Hz)	
Critical Rate of Rise of On-State Current (Note 3)		di/dt	200	A/ μs
Peak Forward Gate Current (Note 4)		I_{FGM}	40	A
Average Forward Gate Power Dissipation		$P_G(AV)$	8	W
R.M.S Reverse Gate Current		$I_{RG}(RMS)$	50	A
Peak Reverse Gate Power Dissipation (Note 5)		P_{RGM}	8	kW
Peak Reverse Gate Voltage		V_{RGM}	15	V
Storage Temperature Range		T_{stg}	-40~115	$^{\circ}C$
Operating Junction Temperature Range		T_j	-40~115	$^{\circ}C$
Mounting Force		-	1200 \pm 120	kg

Note 1 : $V_D=1/2$ Rated, $V_{DM}=2/3$ Rated, $C_S=2\mu F$, $R_S=20\Omega$, $di/dt=25A/\mu s$
 $I_{RG} \leq 220A$, $T_j=115^{\circ}C$, ($V_{DSP} \leq 500V$)

Note 2 : Half sine waveform

Note 3 : $V_D=1/2$ Rated, $I_{TM}=800A$, $I_G=12A$, $t_r=1\mu s$, $f=50Hz$, $T_j=115^{\circ}C$

Note 4 : Pulse width : Max. 20 μs , Duty : Max. 20%

Note 5 : Pulse width : Max. 20 μs , Duty : Max. 2%

Unit in mm

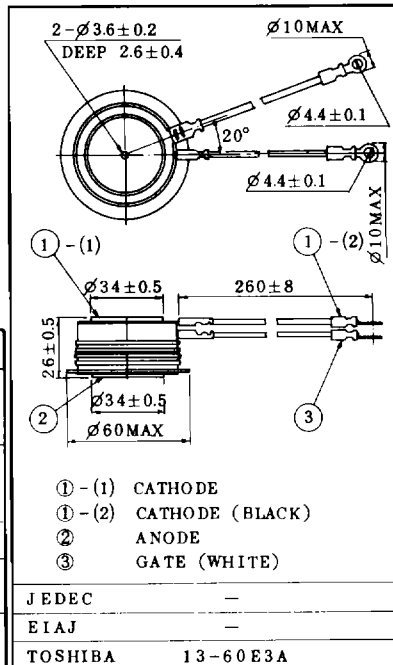

Weight : 290g

ELECTRICAL CHARACTERISTICS

CHARACTERISTIC	SYMBOL	TEST CONDITION	MIN.	TYP.	MAX.	UNIT	
Repetitive Peak Off-State Current	I_{DRM}	V_{DRM} =Rated, $R_{GK}=20\Omega$ $T_j=115^\circ\text{C}$	-	-	50	mA	
Repetitive Peak Reverse Current	I_{RRM}	V_{RRM} =Rated, $T_j=115^\circ\text{C}$	-	-	50	mA	
Repetitive Peak Reverse Gate Current	I_{RCM}	V_{RCM} =Rated, $T_j=115^\circ\text{C}$	-	-	10	mA	
Peak On-State Voltage	V_{TM}	$I_{TM}=800\text{A}$, $T_c=25^\circ\text{C}$	-	-	4.5	V	
Gate Trigger Voltage	V_{GT}	$V_D=24\text{V}$ $R_L=1\Omega$	$T_c=-40^\circ\text{C}$	-	-	1.7	V
			$T_c=25^\circ\text{C}$	-	-	1.2	
Gate Trigger Current	I_{GT}	$R_L=1\Omega$	$T_c=-40^\circ\text{C}$	-	-	2500	mA
			$T_c=25^\circ\text{C}$	-	-	800	
Gate Non-Trigger Voltage	V_{GD}	$V_D=1/2$ Rated, $T_c=115^\circ\text{C}$	0.3	-	-	V	
Gate Non-Trigger Current	I_{GD}		5	-	-	mA	
Delay Time	t_d	$V_D=1/2$ Rated $di/dt=200\text{A}/\mu\text{s}$	-	-	2.0	μs	
Turn-On Time	t_{gt}	$I_{TM}=800\text{A}$, $I_G=12\text{A}$ $t_r=1\mu\text{s}$, $T_c=25^\circ\text{C}$	-	-	8.0	μs	
Critical Rate of Rise of Off-State Voltage	dv/dt	$V_{DRM}=2/3$ Rated $T_j=115^\circ\text{C}$, $V_{GK}=-4\text{V}$ Exponential Rise	900	-	-	$\text{V}/\mu\text{s}$	
Holding Current	I_H	$T_c=25^\circ\text{C}$, $R_L=1\Omega$	-	20	-	A	
Storage Time	t_s	$I_T=800\text{A}$, $V_D=1/2$ Rated	-	-	15	μs	
Gate Turn-Off Time	t_{gq}	$V_{DM}=2/3$ Rated, $C_S=2\mu\text{F}$ $di_{RG}/dt=-25\text{A}/\mu\text{s}$	-	-	17	μs	
Tail Time	t_{tail}		-	-	180	μs	
Turn-Off Gate Current	I_{RG}		$T_c=110^\circ\text{C}$	-	220	260	A
Thermal Resistance	$R_{th(j-f)}$	Junction to Fin	-	-	0.05	$^\circ\text{C}/\text{W}$	