

Return Path Analog CATV Detector Modules

EPM 705 Series

**Key Features**

- **Electro-optical**
 - Low intermodulation distortion
 - High responsivity
 - Low back reflection
- **Packaging**
 - Single mode 900 μm fiber with or without a connector
 - Single mode 250 μm fiber without a connector

Applications

- AM fiber optic CATV receivers to 550 MHz (EPM 705)
- Multi-channel fiber optic transmission

The EPM 705 series are high quality analog photodetectors designed for return path AM CATV applications. These coaxial modules are optically aligned to optimize performance and balance the parameters of responsivity, distortion and back reflection.

The photodetector die is fabricated with a proprietary InGaAs process in our wafer fab and assembled into a hermetically-sealed package with an antireflective-coated lens. A stainless steel bushing is used to actively couple the fiber to the package.

The fiber is reinforced with a rubber boot which relieves fiber bending stresses. The EPM 705 series can be produced without a connector or with a variety of industry standard connectors. They are also available with a mounting bracket which allows both vertical panel mounting and horizontal flush-to-board mounting.

2

Dimensions Diagram

(Specifications in mm unless otherwise noted.)

EPM 705 with Dual Mount Bracket

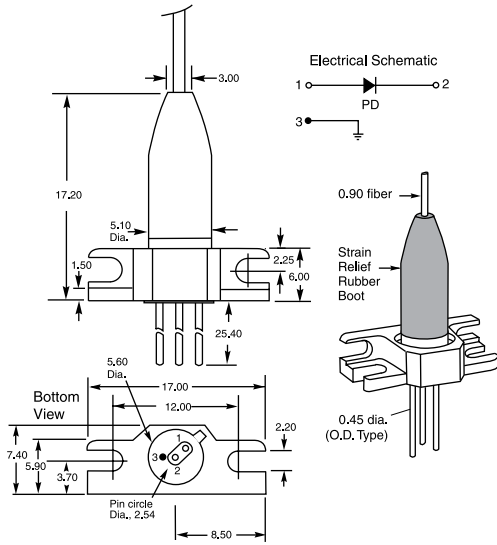

EPM 705 without Dual Mount Bracket

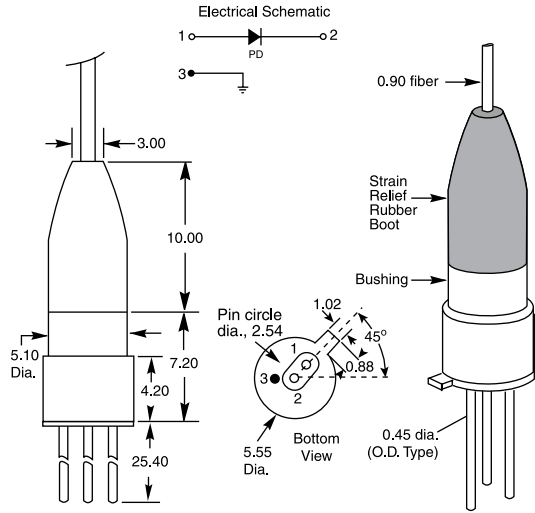

3

Dark Current vs. Reverse Bias

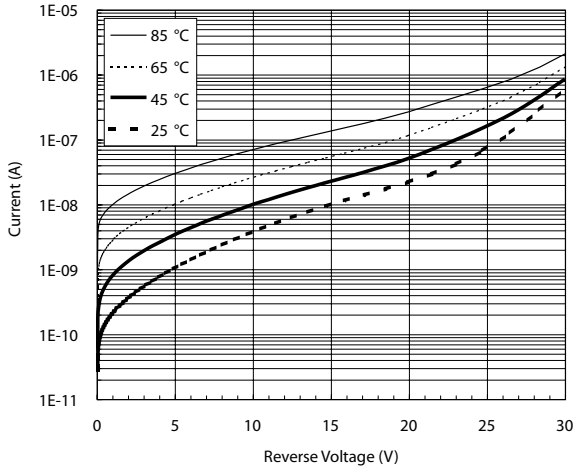

Capacitance vs. Reverse Bias 23°C

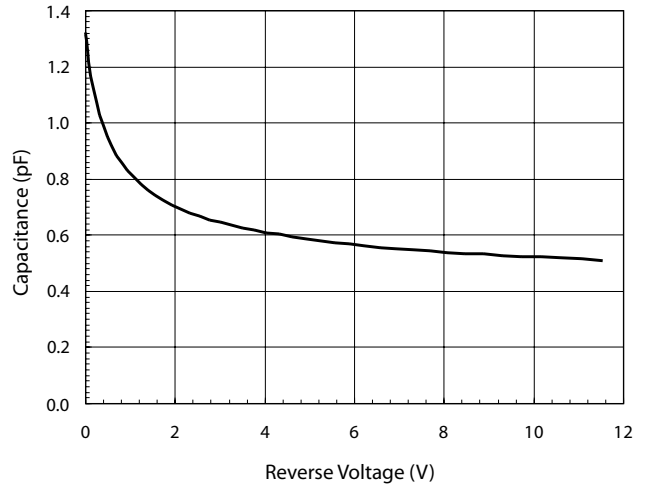

Typical Spectral Response 23°C

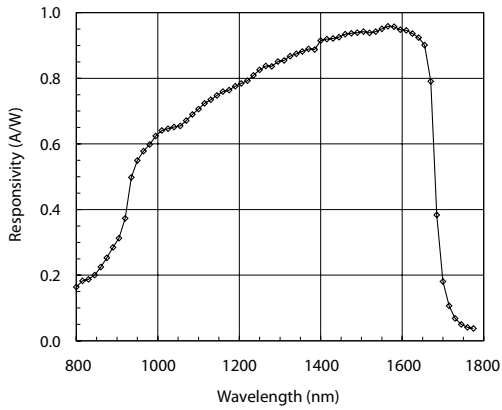

4

Specifications(Temperature = 25°C, $V_R = 5$ V unless noted. All specifications without connector.)

Parameter	Conditions		EPM 705
Responsivity	$\lambda = 1310$ nm	Minimum	0.80 A/W
	$\lambda = 1550$ nm	Minimum	0.85 A/W
Distortion product IM_2		Maximum	-70 dBc ¹
Back reflection		Maximum	-40 dB
Dark current		Maximum	5.0 nA
Capacitance ³		Maximum	0.75 pF
Bandwidth ⁴		Typical	2.0 GHz
Single mode fiber 900 μ m 8.7/125 μ m core/cladding		Minimum	1.0 m
		Maximum	1.5 m

- IM_2 measured at $V_R = 12$ V, $P_{avg} = 0$ dBm, $MI = 0.7$, $R_{load} = 50 \Omega$, $f_1 + f_2 = 324.25$ MHz, $f_1 - f_2 = 54.25$ MHz.
- IM_2 measured at $V_R = 12$ V, $P_{avg} = 0$ dBm, $MI = 0.7$, $R_{load} = 50 \Omega$, $f_1 + f_2 = 850.25$ MHz, $f_1 - f_2 = 50.25$ MHz.
- Measured with case grounded.
- 3 dB point into a 50 Ω load.

Maximum Ratings

Parameter		Specification
Forward current ¹	Minimum	10 mA
Reverse current ²	Minimum	10 mA
Reverse voltage	Minimum	25 V
Power dissipation	Minimum	100 mW
Operating case temperature	Minimum	-40°C
	Maximum	85°C
Soldering temperature	Minimum	260°C
Storage temperature	Minimum	-40°C
	Maximum	85°C

- Under forward bias, current at which device may be damaged.
- Under reverse bias, current at which device may be damaged.

Ordering Information

For more information on this or other products and their availability, please contact your local JDSU account manager or JDSU directly at 1-800-498-JDSU (5378) in North America and +800-5378-JDSU worldwide, or via e-mail at customer.service@jdsu.com.

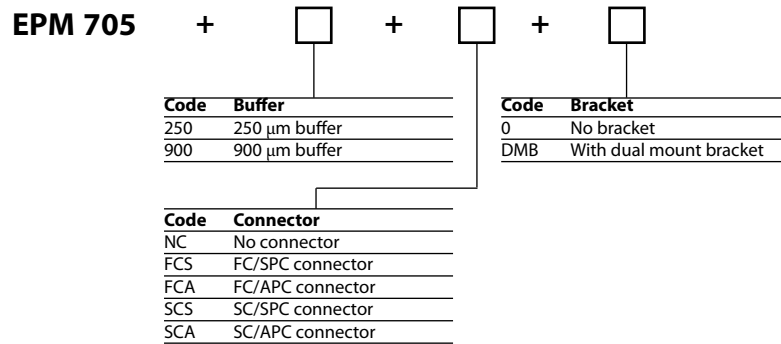
Sample: EPM 705 900 FCA DMB

Precautions for Use

ESD protection is imperative. Use of grounding straps, anti-static mats, and other standard ESD protective equipment is recommended when handling or testing an InGaAs PIN or any other junction photodiode.

Soldering temperature of the leads should not exceed 260 °C for more than 10 seconds.

Fiber pigtailed should be handled with less than 10 N pull and with a bending radius greater than 1 inch.