

# IS455

## Linear Output Type OPIC Light Detector

### ■ Features

1. Linear output
2. Capable of output voltage level adjustment due to external resistor

### ■ Applications

1. Copiers

### ■ Outline Dimensions

(Unit : mm)

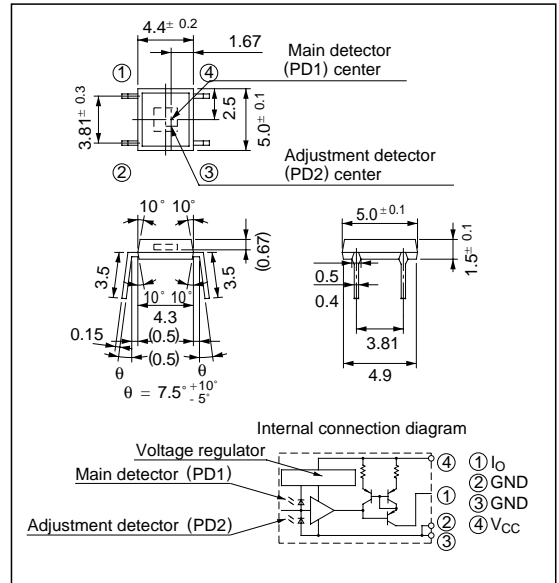

\*\*\* OPIC™ (Optical IC) is a trademark of the SHARP Corporation.  
An OPIC consists of a light-detecting element and signal-processing circuit integrated onto a single chip.

### ■ Enlarged Figure of Light Detecting Portion

(Unit : μm)

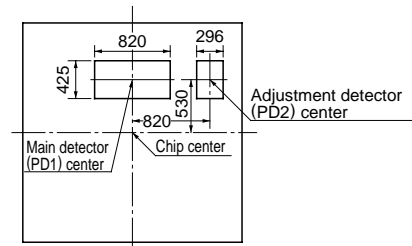

### ■ Absolute Maximum Ratings (Ta= 25°C)

Parameter	Symbol	Rating	Unit
Supply voltage	V <sub>CC</sub>	-0.5 to +8	V
Output voltage	V <sub>O</sub>	-0.5 to V <sub>CC</sub>	V
Output current	I <sub>O</sub>	- 10	mA
Power dissipation	P <sub>O</sub>	150	mW
Operating temperature	T <sub>opr</sub>	-25 to +85	°C
Storage temperature	T <sub>stg</sub>	-40 to +85	°C
*1 Soldering temperature	T <sub>sol</sub>	260	°C

\*1 For 3 seconds at the position of 1mm from the bottom face of resin package.

## ■ Electro-optical Characteristics

( $T_a = 25^\circ\text{C}$ ,  $V_{CC} = 5\text{V}$ )

Parameter	Symbol	Conditions	MIN.	TYP.	MAX.	Unit
Supply current	$I_{CC}$	$E_v = 0\text{ lx}$	0.2	0.55	1.0	mA
Output current 1	$I_{O1}$	$E_v = 10\text{ lx}^{*2}$	-6.5	-10	-13.5	$\mu\text{A}$
Output current 2	$I_{O2}$	$E_v = 1\ 000\text{ lx}^{*2}$	-0.65	-1	-1.35	mA
<sup>*3</sup> Output current ratio	$R_{IO}$	-	92	100	108	-
Dark output current	$I_{od}$	$E_v = 0$	-	-10	-500	nA
Peak sensitivity wavelength	$\lambda_P$	-	-	700	-	nm

<sup>\*2</sup>  $E_v$ : Illuminance by CIE standard light source A (tungsten lamp)

<sup>\*3</sup>  $R_{IO} = \frac{I_{O2}}{I_{O1}}$

## ■ Recommended Operating Conditions

Parameter	Symbol	MIN.	MAX.	Unit
Supply voltage	$V_{CC}$	4.5	5.5	V
<sup>*4</sup> Illuminance	$E_v$	10	5\ 000	lx
Output voltage	$V_O$	0	$V_{CC} - 1.5$	V
Operating temperature	$T_{opr}$	-10	70	$^\circ\text{C}$

<sup>\*4</sup>  $E_v$ : Illuminance by standard light source A (tungsten lamp)

**Fig. 1 Power Dissipation vs. Ambient Temperature**

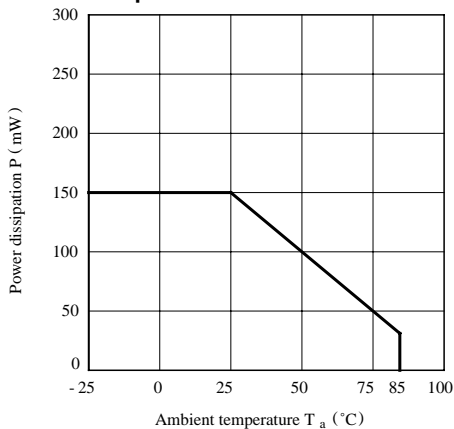

**Fig. 2 Output Current vs. Illuminance**

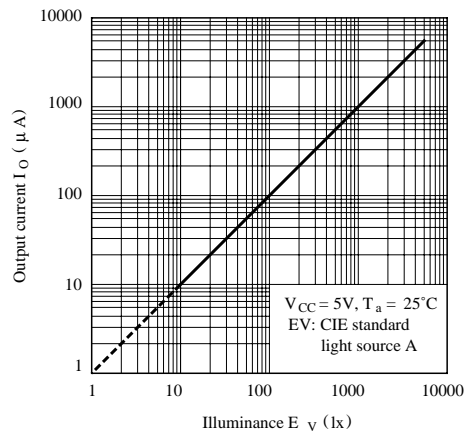

**Fig. 3 Spectral Sensitivity**

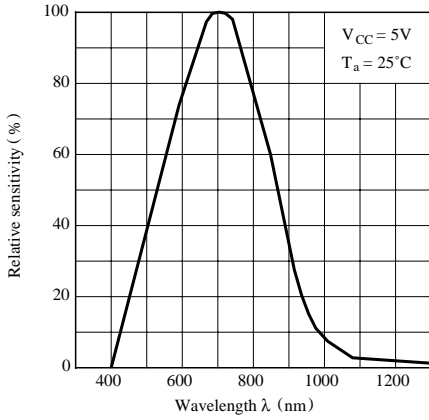

**Fig. 4 Relative Output Current vs. Ambient Temperature**

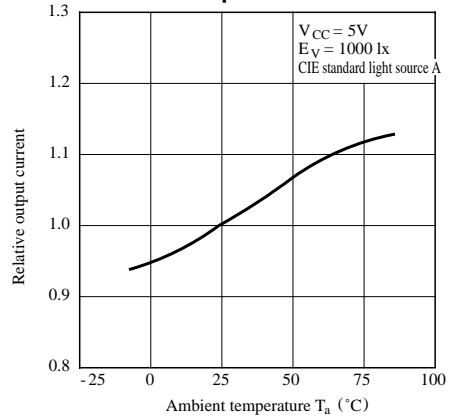

**Fig. 5 Dark Output Current vs. Ambient Temperature**

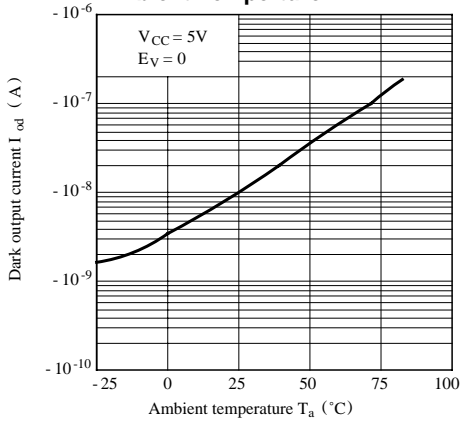

**Fig. 6 Output Current vs. Supply Voltage**

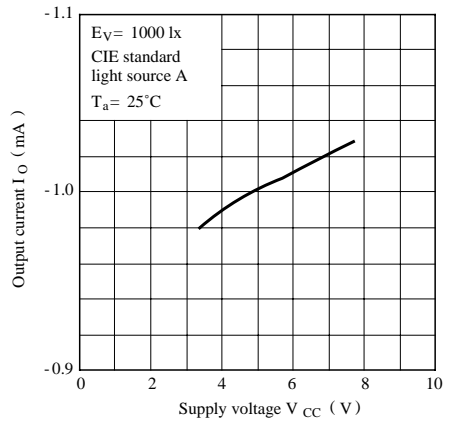

**Fig. 7 Output Current vs. Output Voltage**

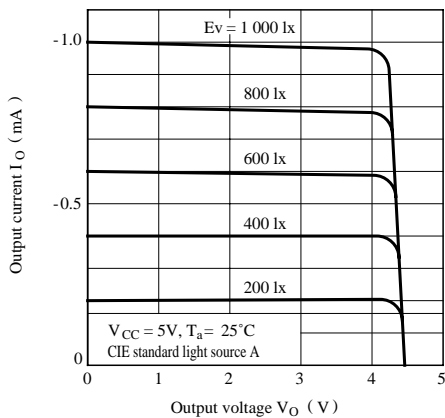

**Test Circuit for Output Current vs. Output Voltage**

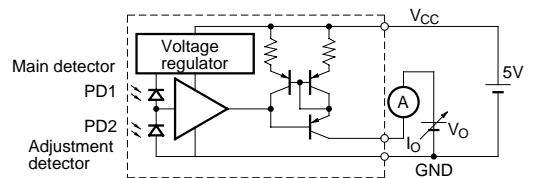

Fig. 8 Supply Current vs. Supply Voltage

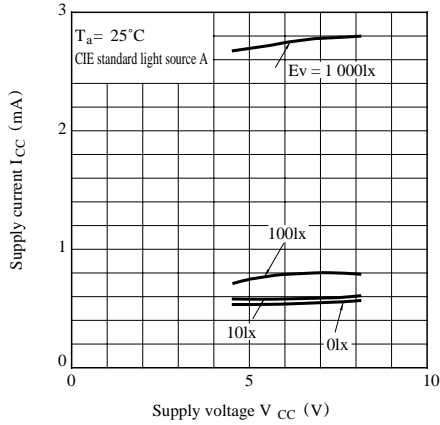

Fig. 9 Supply Current vs. Threshold Illuminance

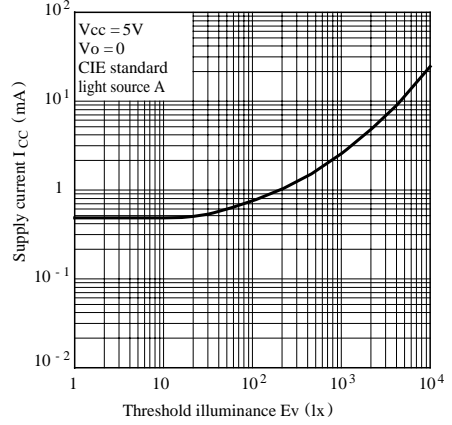
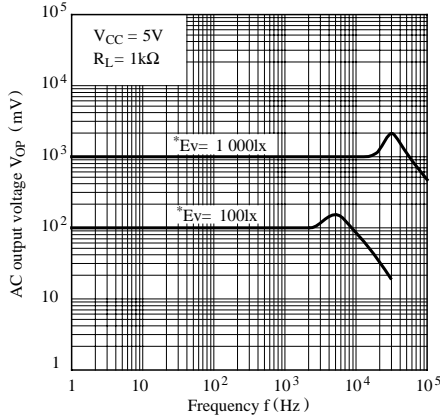

Fig.10 Frequency



Test Circuit For Frequency

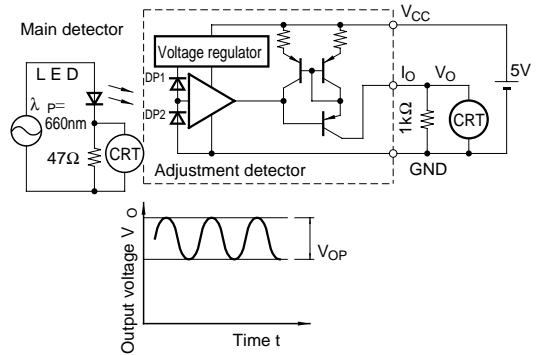

Fig.11 Supply Voltage Rejection Ratio vs. Ripple Frequency (1)

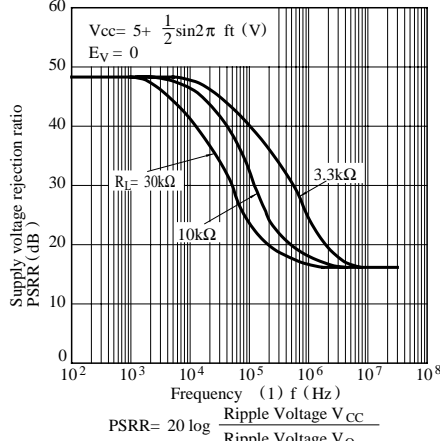
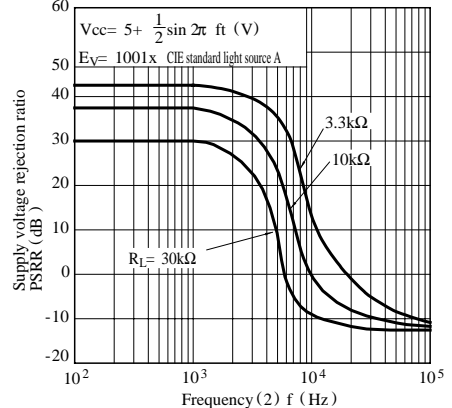

Fig.12 Supply Voltage Rejection Ratio vs. Ripple Frequency (2)



### NOTICE

- The circuit application examples in this publication are provided to explain representative applications of SHARP devices and are not intended to guarantee any circuit design or license any intellectual property rights. SHARP takes no responsibility for any problems related to any intellectual property right of a third party resulting from the use of SHARP's devices.
- Contact SHARP in order to obtain the latest device specification sheets before using any SHARP device. SHARP reserves the right to make changes in the specifications, characteristics, data, materials, structure, and other contents described herein at any time without notice in order to improve design or reliability. Manufacturing locations are also subject to change without notice.
- Observe the following points when using any devices in this publication. SHARP takes no responsibility for damage caused by improper use of the devices which does not meet the conditions and absolute maximum ratings to be used specified in the relevant specification sheet nor meet the following conditions:
  - (i) The devices in this publication are designed for use in general electronic equipment designs such as:
    - Personal computers
    - Office automation equipment
    - Telecommunication equipment [terminal]
    - Test and measurement equipment
    - Industrial control
    - Audio visual equipment
    - Consumer electronics
  - (ii) Measures such as fail-safe function and redundant design should be taken to ensure reliability and safety when SHARP devices are used for or in connection with equipment that requires higher reliability such as:
    - Transportation control and safety equipment (i.e., aircraft, trains, automobiles, etc.)
    - Traffic signals
    - Gas leakage sensor breakers
    - Alarm equipment
    - Various safety devices, etc.
  - (iii) SHARP devices shall not be used for or in connection with equipment that requires an extremely high level of reliability and safety such as:
    - Space applications
    - Telecommunication equipment [trunk lines]
    - Nuclear power control equipment
    - Medical and other life support equipment (e.g., scuba).
- Contact a SHARP representative in advance when intending to use SHARP devices for any "specific" applications other than those recommended by SHARP or when it is unclear which category mentioned above controls the intended use.
- If the SHARP devices listed in this publication fall within the scope of strategic products described in the Foreign Exchange and Foreign Trade Control Law of Japan, it is necessary to obtain approval to export such SHARP devices.
- This publication is the proprietary product of SHARP and is copyrighted, with all rights reserved. Under the copyright laws, no part of this publication may be reproduced or transmitted in any form or by any means, electronic or mechanical, for any purpose, in whole or in part, without the express written permission of SHARP. Express written permission is also required before any use of this publication may be made by a third party.
- Contact and consult with a SHARP representative if there are any questions about the contents of this publication.