

NE5520 LVDT Signal Conditioner

Product Specification

Linear Products

DESCRIPTION

The NE5520 is a signal conditioning circuit for use with Linear Variable Differential Transformers (LVDT). The chip includes a low distortion amplitude stable sine wave oscillator with programmable frequency to drive the primary of the LVDT; a synchronous demodulator to convert the LVDT output amplitude and phase to position information; and an output amp to provide gain and filtering.

FEATURES

- Oscillator frequency: 1kHz to 20kHz
- Low distortion
- Capable of ratiometric operation
- Single supply operation 5V to 20V or dual supply $\pm 2.5V$ to $\pm 10V$
- Low power consumption

APPLICATIONS

- LVDT signal conditioning
- RVDT signal conditioning

ORDERING INFORMATION

DESCRIPTION	TEMPERATURE RANGE	ORDER CODE
14-Pin Plastic DIP	0 to +70°C	NE5520N
16-Pin SOL Package	0 to +70°C	NE5520D
16-Pin Ceramic DIP	0 to +70°C	NE5520F

ABSOLUTE MAXIMUM RATINGS

SYMBOL	PARAMETER	RATING	UNIT
V_S	Supply voltage	+20	V
	Split supply voltage	± 10	V
T_A	Operating temperature range	0 to +70	°C
T_{STG}	Storage temperature range	-65 to +165	°C
P_D	Power Dissipation ¹	840	mW

NOTES:

1. Supplied only in large SO (Small Outline) package. See package diagram.
2. Pin numbers are for N package.

PIN CONFIGURATIONS

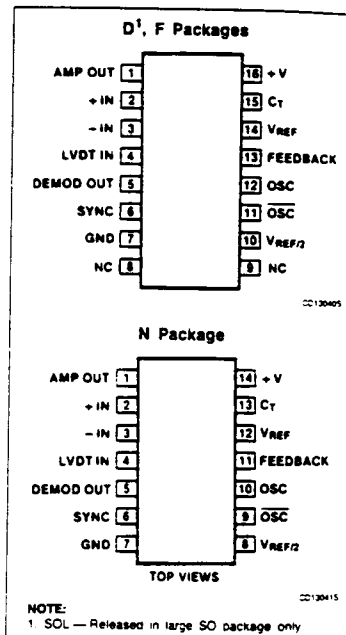

LVDT Signal Conditioner

NE5520

BLOCK DIAGRAM

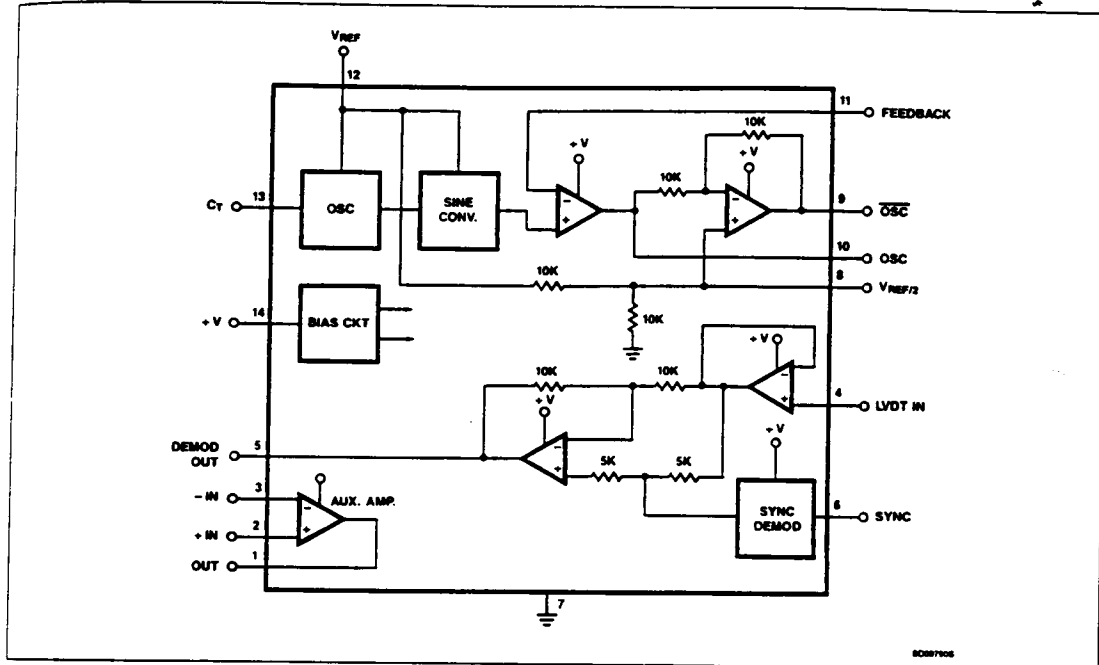

LVDT Signal Conditioner

NE5520

DC ELECTRICAL CHARACTERISTICS $T_A = 25^\circ\text{C}$, $V_R = V^+ = 10\text{V}$, unless otherwise specified.

SYMBOL	PARAMETER	TEST CONDITIONS	LIMITS			UNIT
			Min	Typ	Max	
I_{CC}	Supply current	Over temperature		7.0	10	mA
I_{REF}	Reference current	Over temperature		5.5	10	mA
V_{REF}	Reference voltage range	Over temperature	5		V^+	V
P_D	Power dissipation			120	220	mW
Oscillator section						
	Oscillator output			$\frac{V_R}{8.7}$		V_{RMS}
	Sine wave distortion			4		%
	Initial amplitude error				± 3	%
	Tempco of amplitude				0.05	%/ $^\circ\text{C}$
	Voltage coefficient of amplitude error				2.5	%/V
	Initial accuracy of oscillator frequency				20	%
	Tempco of frequency error			0.05		%/ $^\circ\text{C}$
	Voltage coefficient of frequency			2.5		%/V(V_R)
	Oscillator output load current	Over temperature	8	15		mA_{RMS} mA_{RMS}
Demodulator section						
E_r	Linearity error	Over temperature		0.05	0.1	%
	Maximum demodulator input	Over temperature range	$\frac{V_R}{2} - 0.5$		$\frac{V_R}{2} + 0.5$	V
	Demodulator offset voltage	Over temperature range			65	mV
	Demodulator input current	Over temperature	-1000	-300		nA
	$V_R/2$ accuracy	Over temperature	-3	± 0.5	+3	%
Auxiliary output amplifier						
V_{OS}	Input offset voltage	Over temperature	-10		10	mV
I_{BIAS}	Input bias current	Over temperature range	-500	-300		nA
I_{OS}	Input offset current		-100		100	nA
A_V	Gain	$R_L = 10\text{k}\Omega$ over temperature		100		V/mV
SR	Slew rate			1.5		V/ μs
GBW	Gain bandwidth	$A_V = 1$		1		MHz
V_{OUT}	Output voltage swing	$R_L = 10\text{k}\Omega$ over temperature	1.5		$V^+ - 1.5$	V
I_{SC}	Output short-circuit current			50		mA

NOTE:

Rating applies to ambient temperatures up to 70°C . Above 70°C derate linearly at $7.6\text{mW}/^\circ\text{C}$ for the plastic package and $7.3\text{mW}/^\circ\text{C}$ for the cerdip package

ISI IDEAL SEMICONDUCTOR INC.

"Your Best Defense Against Obsolescence"

Product Specification

LVDT Signal Conditioner

NE5520

TYPICAL PERFORMANCE CHARACTERISTICS

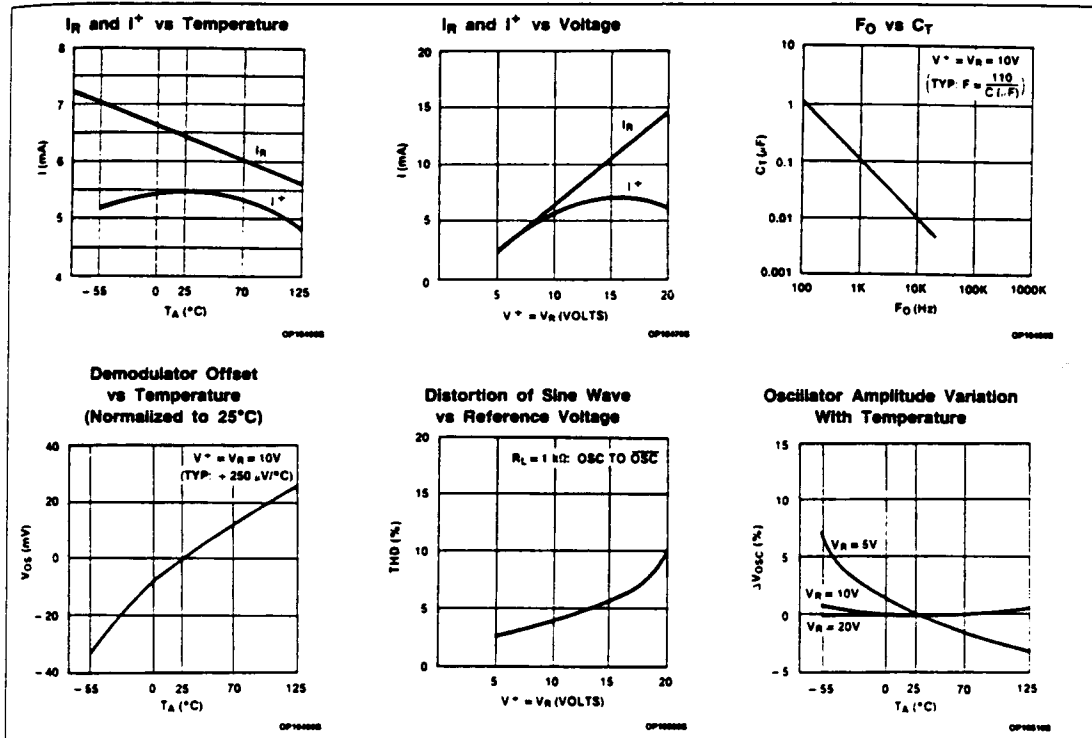

LVDT Signal Conditioner

NE5520

TYPICAL SINGLE SUPPLY LVDT CIRCUIT

