

UT54ACS190/UT54ACTS190

Radiation-Hardened Synchronous 4-Bit Up-Down BCD Counters

FEATURES

- Single down/up count control line
- Look-ahead circuitry enhances speed of cascaded counters
- Fully synchronous in count modes
- Asynchronously presettable with load control
- 1.2μ radiation-hardened CMOS
 - Latchup immune
- High speed
- Low power consumption
- Single 5 volt supply
- Available QML Q or V processes
- Flexible package
 - 16-pin DIP
 - 16-lead flatpack

DESCRIPTION

The UT54ACS190 and the UT54ACTS190 are synchronous 4-bit reversible up-down BCD decade counters. Synchronous counting operation is provided by having all flip-flops clocked simultaneously so that the outputs change coincident with each other when so instructed. Synchronous operation eliminates the output counting spikes associated with asynchronous counters.

The outputs of the four flip-flops are triggered on a low-to-high-level transition of the clock input if the enable input (\overline{CTEN}) is low. A logic one applied to \overline{CTEN} inhibits counting. The direction of the count is determined by the level of the down/up (D/U) input. When D/U is low, the counter counts up and when D/U is high, it counts down.

The counters feature a fully independent clock circuit. Changes at control inputs (\overline{CTEN} and D/U) that will modify the operating mode have no effect on the contents of the counter until clocking occurs.

The counters are fully programmable. The outputs may be preset to either logic level by placing a low on the load input and entering the desired data at the data inputs. The output will change to agree with the data inputs independently of the level of the clock input. The asynchronous load allows counters to be used as modulo-N dividers by simply modifying the count length with the preset inputs.

If preset to an illegal state, the counter returns to a normal sequence in one or two counts.

PINOUTS

16-Pin DIP
Top View

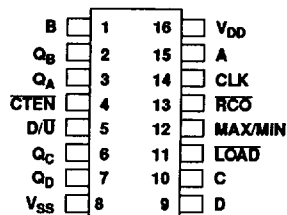

16-Lead Flatpack
Top View

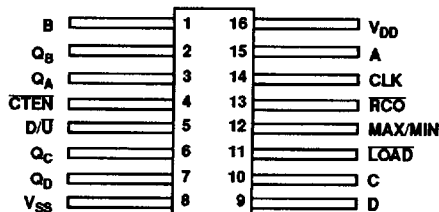

Two outputs have been made available to perform the cascading function: ripple clock and maximum/minimum (MAX/MIN) count. The MAX/MIN output produces a high-level output pulse with a duration approximately equal to one complete cycle of the clock while the count is zero (all outputs low) counting down or maximum (9) counting up.

The ripple clock output (\overline{RCO}) produces a low-level output pulse under those same conditions but only while the clock input is low. The counters easily cascade by feeding the \overline{RCO} to the enable input of the succeeding counter if parallel clocking is used, or to the clock input if parallel enabling is used. Use the MAX/MIN count output to accomplish look-ahead for high-speed operation.

The devices are characterized over full military temperature range of -55°C to +125°C.

FUNCTION TABLE

Function	LOAD	CTEN	D/U	CLK
Count up	H	L	L	↑
Count down	H	L	H	↑
Asynchronous Reset	L	X	X	X
No change	H	H	X	X

LOGIC SYMBOL

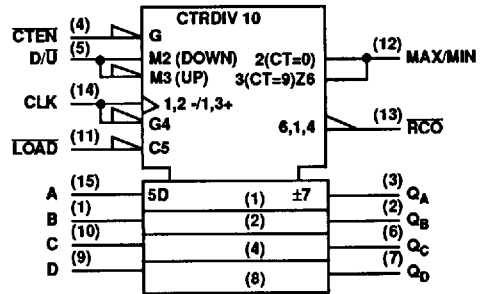

Note:

1. Logic symbol in accordance with ANSI/IEEE standard 91-1984 and IEC Publication 617-12.

LOGIC DIAGRAM

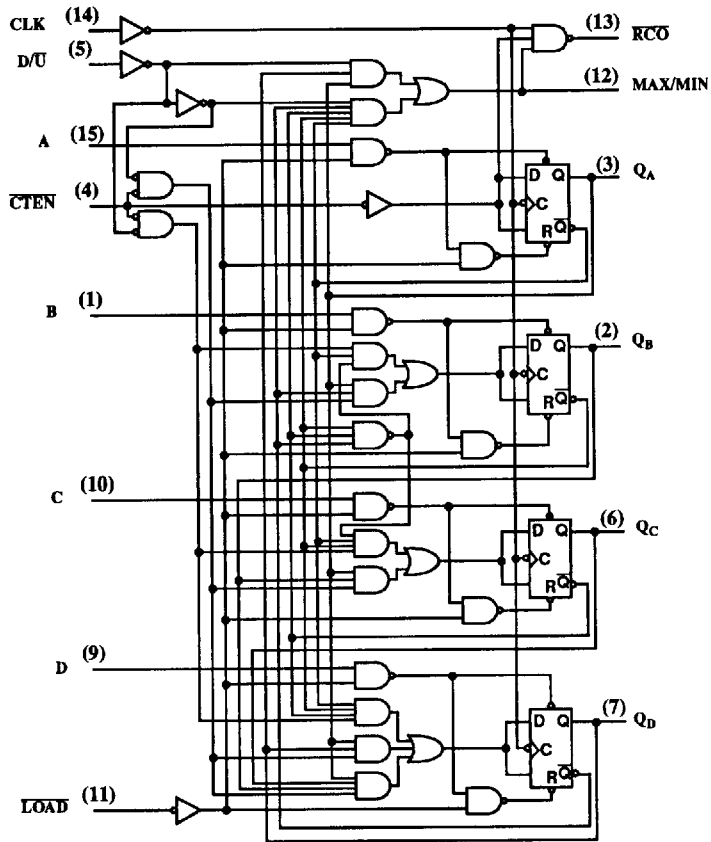

RADIATION HARDNESS SPECIFICATIONS ¹

PARAMETER	LIMIT	UNITS
Total Dose	1.0E6	rads(Si)
SEU & SEL Threshold ²	80	MeV-cm ² /mg
Neutron Fluence	1.0E14	n/cm ²

Notes:

1. Logic will not latchup during radiation exposure within the limits defined in the table.
2. Device storage elements are immune to SEU affects.

ABSOLUTE MAXIMUM RATINGS

SYMBOL	PARAMETER	LIMIT	UNITS
V _{DD}	Supply voltage	-0.3 to 7.0	V
V _{IO}	Voltage any pin	-.3 to V _{DD} +.3	V
T _{STG}	Storage Temperature range	-65 to +150	°C
T _J	Maximum junction temperature	+175	°C
T _{LS}	Lead temperature (soldering 5 seconds)	+300	°C
θ _{JC}	Thermal resistance junction to case	20	°C/W
I _I	DC input current	±10	mA
P _D	Maximum power dissipation	1	W

Note:

1. Stresses outside the listed absolute maximum ratings may cause permanent damage to the device. This is a stress rating only, functional operation of the device at these or any other conditions beyond limits indicated in the operational sections is not recommended. Exposure to absolute maximum rating conditions for extended periods may affect device reliability.

RECOMMENDED OPERATING CONDITIONS

SYMBOL	PARAMETER	LIMIT	UNITS
V _{DD}	Supply voltage	4.5 to 5.5	V
V _{IN}	Input voltage any pin	0 to V _{DD}	V
T _C	Temperature range	-55 to + 125	°C

DC ELECTRICAL CHARACTERISTICS ⁷(V_{DD} = 5.0V ±10%; V_{SS} = 0V ⁶, -55°C < T_C < +125°C)

SYMBOL	PARAMETER	CONDITION	MIN	MAX	UNIT
V _{IL}	Low-level input voltage ¹ ACTS ACS			0.8 .3V _{DD}	V
V _{IH}	High-level input voltage ¹ ACTS ACS		.5V _{DD} .7V _{DD}		V
I _{IN}	Input leakage current ACTS/ACS	V _{IN} = V _{DD} or V _{SS}	-1	1	μA
V _{OL}	Low-level output voltage ³ ACTS ACS	I _{OL} = 8.0mA I _{OL} = 100μA		0.40 0.25	V
V _{OH}	High-level output voltage ³ ACTS ACS	I _{OH} = -8.0mA I _{OH} = -100μA	.7V _{DD} V _{DD} - 0.25		V
I _{OS}	Short-circuit output current ^{2,4} ACTS/ACS	V _O = V _{DD} and V _{SS}	-200	200	mA
P _{total}	Power dissipation ^{8,9}	C _L = 50pF		2.2	mW/MHz
I _{DDQ}	Quiescent Supply Current	V _{DD} = 5.5V		10	μA
C _{IN}	Input capacitance ⁵	f = 1MHz @ 0V		15	pF
C _{OUT}	Output capacitance ⁵	f = 1MHz @ 0V		15	pF

Notes:

- Functional tests are conducted in accordance with MIL-STD-883 with the following input test conditions: V_{IH} = V_{IH}(min) + 20%, - 0%; V_{IL} = V_{IL}(max) + 0%, - 50%, as specified herein, for TTL, CMOS, or Schmitt compatible inputs. Devices may be tested using any input voltage within the above specified range, but are guaranteed to V_{IH}(min) and V_{IL}(max).
- Supplied as a design limit but not guaranteed or tested.
- Per MIL-M-38510, for current density ≤ 5.0E5 amps/cm², the maximum product of load capacitance (per output buffer) times frequency should not exceed 3,765 pF MHz.
- Not more than one output may be shorted at a time for maximum duration of one second.
- Capacitance measured for initial qualification and when design changes may affect the value. Capacitance is measured between the designated terminal and V_{SS} at frequency of 1MHz and a signal amplitude of 50mV rms maximum.
- Maximum allowable relative shift equals 50mV.
- All specifications valid for radiation dose ≤ 1E6 rads(Si).
- Power does not include power contribution of any TTL output sink current.
- Power dissipation specified per switching output.

UT54ACS190/UT54ACTS190

AC ELECTRICAL CHARACTERISTICS ²

(V_{DD} = 5.0V ±10%; V_{SS} = 0V¹, -55°C < T_C < +125°C)

SYMBOL	PARAMETER	MINIMUM	MAXIMUM	UNIT
t _{PLH}	LOAD to Q _n	2	19	ns
t _{PHL}	LOAD to Q _n	2	22	ns
t _{PLH}	Data In to Q _n	2	19	ns
t _{PHL}	Data In to Q _n	2	23	ns
t _{PLH}	CLK to Q _n	2	18	ns
t _{PHL}	CLK to Q _n	2	22	ns
t _{PLH}	CLK to RCO	2	12	ns
t _{PHL}	CLK to RCO	2	16	ns
t _{PLH}	CLK to MAX/MIN	2	22	ns
t _{PHL}	CLK to MAX/MIN	2	25	ns
t _{PLH}	D/U to RCO	2	16	ns
t _{PHL}	D/U to RCO	2	18	ns
t _{PLH}	D/U to MAX/MIN	1	14	ns
t _{PHL}	D/U to MAX/MIN	2	18	ns
t _{PLH}	CTEN to RCO	2	12	ns
t _{PHL}	CTEN to RCO	2	16	ns
f _{MAX}	Maximum clock frequency		71	MHz
t _{SU}	Setup time before CLK ↑ CTEN D/U	13		ns
	Setup time before CLK ↑ LOAD	2		
	A, B, C, D setup time before LOAD ↑	5		
t _H	CTEN and D/U hold time after CLK ↑ A, B, C, D hold time after LOAD ↑	2		ns
t _w	Minimum pulse width CLK high CLK low LOAD low	7		ns

Notes:

1. Maximum allowable relative shift equals 50mV.
2. All specifications valid for radiation dose ≤ 1E6 rads(Si).

2.0 RAD-HARD MSI PACKAGES

Side-Brazed Packages

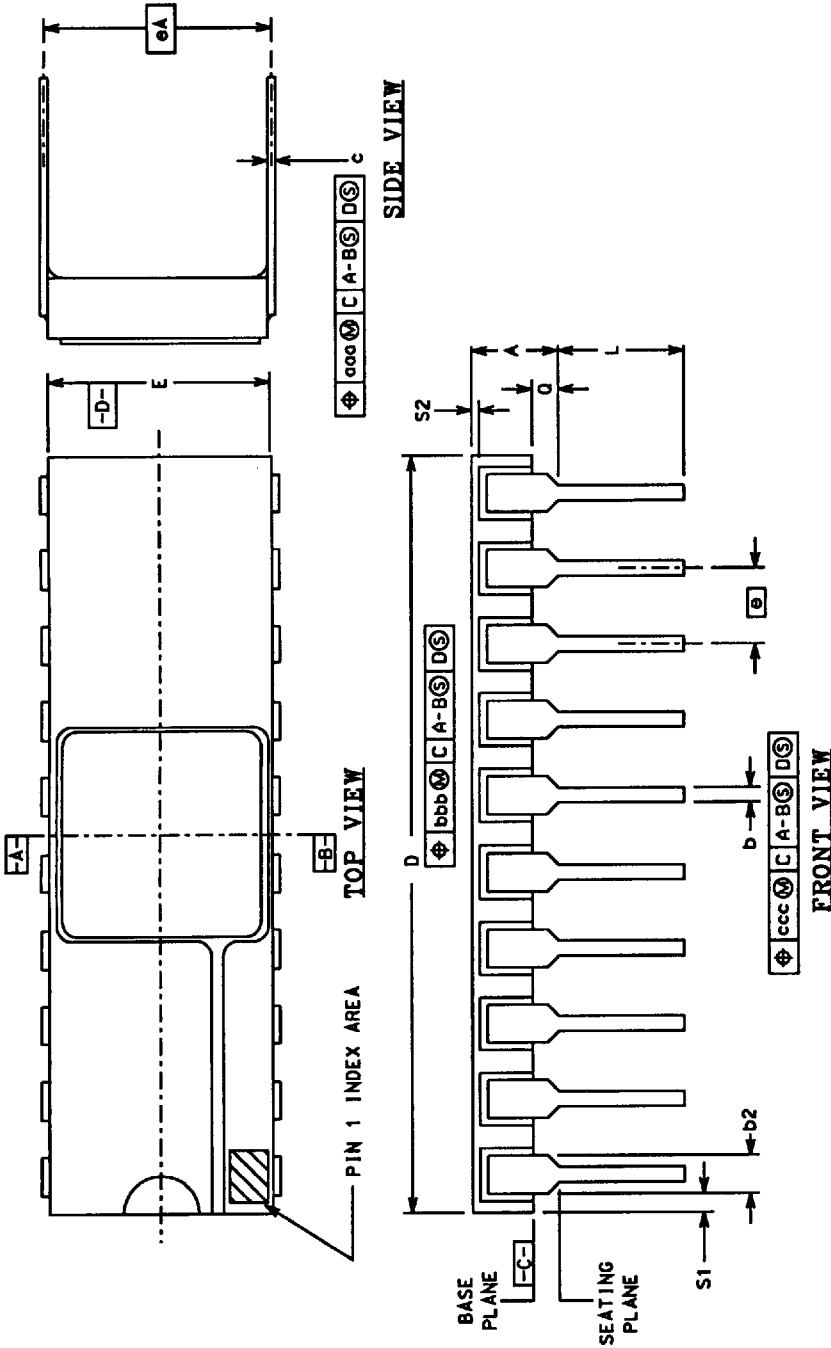

PKG CONFIG	MIL-STD- 1835 Dwg CONF C	DIMENSION SYMBOLS													
		A	b	b2	c	D	E	e	eA	L	Q	S1	S2	bbb	ccc
-01	14 D-1	0.200	0.026	0.065	0.018	0.785	0.310	0.100	0.300	0.200	0.060	0.005	0.005	0.015	0.010
-02	16 D-2	0.200	0.014	0.065	0.018	0.840	0.310	0.100	0.300	0.200	0.060	0.005	0.005	0.015	0.010
-03	20 D-8	0.200	0.026	0.065	0.018	1.060	0.310	0.100	0.300	0.200	0.070	0.005	0.005	0.015	0.010
			0.014	0.045	0.008		0.220	0.100	0.300	0.125	0.015	0.005	0.005	0.030	0.010
			0.014	0.045	0.008		0.220	0.100	0.300	0.125	0.015	0.005	0.005	0.030	0.010
			0.014	0.045	0.008		0.220	0.100	0.300	0.125	0.015	0.005	0.005	0.030	0.010

Flatpack Packages

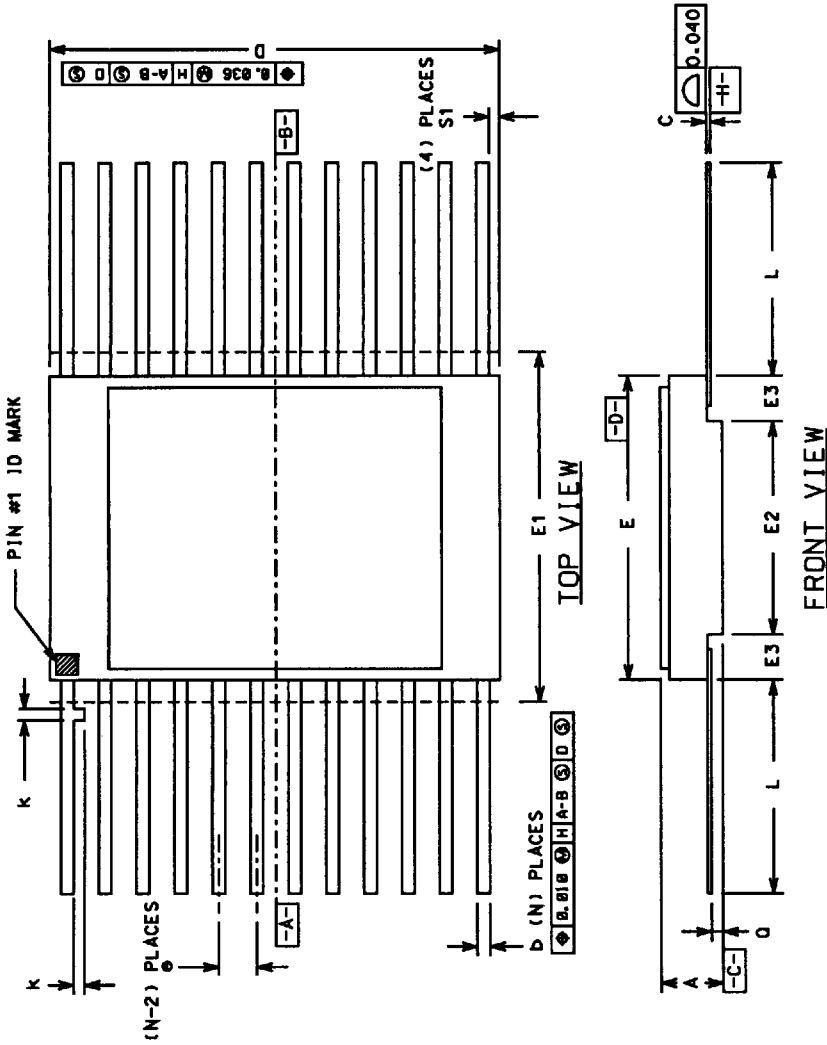

PKG CONFIG	LEAD COUNT	MIL-STD 1835 DWG CONF B	DIMENSION SYMBOLS													
			A	b	c	D	E	E1	E2	E3	e	k	L	O	S1	
-03	14	F-2A	0.115 0.045	0.022 0.015	0.009 0.004	0.390 0.290	0.260 0.235	0.130	0.290	0.130	0.030	0.050 BSC	0.015 0.008	0.370 0.270	0.045 0.026	0.005
-04	16	F-5A	0.115 0.045	0.022 0.015	0.009 0.004	0.440 0.245	0.285 0.245	0.130	0.315	0.130	0.030	0.050 BSC	0.015 0.008	0.370 0.250	0.045 0.026	0.005
-05	20	F-9A	0.115 0.045	0.022 0.015	0.009 0.004	0.540 0.245	0.300 0.245	0.130	0.330	0.130	0.030	0.050 BSC	0.015 0.008	0.370 0.250	0.045 0.026	0.000