

LH0094



T-73-31

LH0094 Multifunction Converter

General Description

The LH0094 multifunction converter generates an output voltage per the transfer function:

$$E_o = V_y \left(\frac{V_z}{V_x} \right)^m, 0.1 \leq m \leq 10, m \text{ continuously adjustable}$$

m is set by 2 resistors.

Features

- Low cost
- Versatile
- High accuracy - 0.05%
- Wide supply range - ±5V to ±22V

- Minimum component count
- Internal matched resistor pair for setting m=2 and m=0.5

Applications

- Precision divider, multiplier
- Square root
- Square
- Trigonometric function generator
- Companding
- Linearization
- Control systems
- Log amp

Block and Connection Diagrams

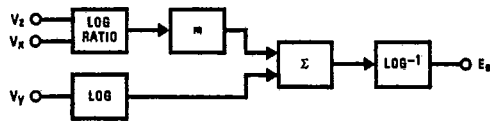

Order Number LH0094D or LH0094CD
See NS Package Number D16D

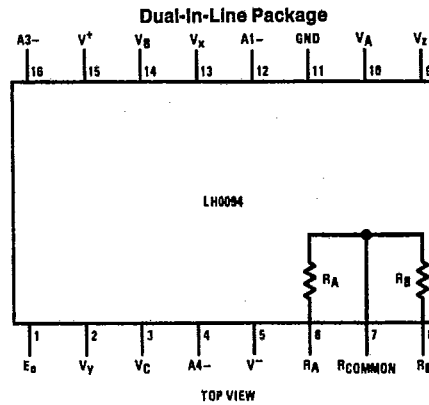

Simplified Schematic

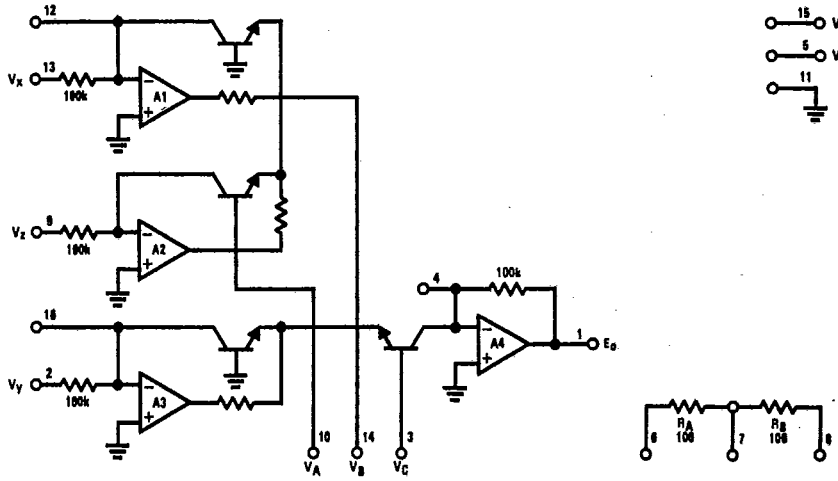

TL/H/5695-1

T-73-31

LH0094

Absolute Maximum Ratings (Note 1)

If Military/Aerospace specified devices are required, please contact the National Semiconductor Sales Office/Distributors for availability and specifications.

Supply Voltage ±22V
 Input Voltage ±22V
 Output Short-Circuit Duration Continuous

Operating Temperature Range
 LH0094CD -25°C to +85°C
 LH0094D -55°C to +125°C
 Storage Temperature Range
 LH0094D -65°C to +150°C
 LH0094CD -55°C to +125°C
 Lead Temperature (Soldering, 10 seconds) 260°C

Electrical Characteristics

$V_S = \pm 15V$, $T_A = 25^\circ C$ unless otherwise specified. Transfer function: $E_O = V_Y \frac{V_Z^m}{V_X}$; $0.1 \leq m \leq 10$; $0V \leq V_X, V_Y, V_Z \leq 10V$

Parameter	Conditions	LH0094			LH0094C			Units
		Min	Typ	Max	Min	Typ	Max	
ACCURACY								
Multiply	$E_O = V_Z V_Y$ ($0.03 \leq V_Y \leq 10V$; $0.01 \leq V_Z \leq 10V$) (Figure 2) vs. Temperature		0.25	0.45		0.45	0.9	% F.S. (10V)
Untrimmed			0.10			0.1		% F.S.
External Trim			0.2			0.2		mV/°C
Divide	$E_O = 10V_Z/V_X$ (Figure 4), ($0.5 \leq V_X \leq 10$; $0.01 \leq V_Z \leq 10$) (Figure 5), ($0.1 \leq V_X \leq 10$; $0.01 \leq V_Z \leq 10$) vs. Temperature		0.25	0.45		0.45	0.9	% F.S.
Untrimmed			0.10			0.1		% F.S.
External Trim			0.2			0.2		mV/°C
Square Root	$E_O = 10\sqrt{V_Z/10}$ (Figure 8), ($0.03 \leq V_Z \leq 10$) (Figure 9), ($0.01 \leq V_Z \leq 10$)		0.25	0.45		0.45	0.9	% F.S.
Untrimmed			0.15			0.15		% F.S.
External Trim								
Square	$E_O = 10(V_Z/10)^2$ ($0.1 \leq V_Z \leq 10$) (Figure 6)	0.5	1.0		1.0	2.0		% F.S.
Untrimmed		0.15			0.15			% F.S.
External Trim								
Low Level	$E_O = \sqrt{10V_Z}$; $5.0mV \leq V_Z \leq 10V$, (Figure 10)		0.05			0.05		% F.S.
Square Root	$m=0.2$, $E_O = 10(V_Z/10)^2$ (Figure 11), ($0.1 \leq V_Z \leq 10$) $m=5.0$, $E_O = 10(V_Z/10)^5$ (Figure 11), ($1.0 \leq V_Z \leq 10$)		0.05			0.08		% F.S.
Exponential			0.05			0.08		% F.S.
Circuits			0.05			0.08		% F.S.
OUTPUT OFFSET								
	$V_X = 10V, V_Y = V_Z = 0$		2.0	5.0		5.0	10	mV
AC CHARACTERISTICS								
3 dB Bandwidth	$m=1.0, V_X=10V, V_Y=0.1 V_{rms}$ 10 Hz to 1.0 kHz, $m=1.0, V_Y=V_Z=0V$ $V_X=10V$ $V_X=0.1V$		10			10		kHz
Noise			100			100		$\mu V/rms$
			300			300		$\mu V/rms$
EXPONENT								
m		0.2 to 5.0	0.1 to 10		0.2 to 5.0	0.1 to 10		
INPUT CHARACTERISTICS								
Input Voltage	(For Rated Performance)	0	10		0	10		V
Input Impedance	(All Inputs)	98	100		98	100		k Ω
OUTPUT CHARACTERISTICS								
Output Swing	($R_L \leq 10k$)	10	12		10	12		V
Output Impedance			1.0			1.0		Ω
Supply Current	($V_S = \pm 15V$) (Note 1)		3.0	5.0		3.0	5.0	mA

Note 1: Refer to RETS0094D drawing for specifications of the military LH0094D version.

5

T-73-31

LH0094

Applications Information

GENERAL INFORMATION

Power supply bypass capacitors (0.1 μ F) are recommended for all applications.

The LH0094 series is designed for positive input signals only. However, negative input up to the supply voltage will not damage the device.

A clamp diode (Figure 1) is recommended for those applications in which the inputs may be subjected to open circuit or negative input signals.

For basic applications (multiply, divide, square, square root) it is possible to use the device without any external adjustments or components. Two matched resistors are provided internally to set m for square or square root.

When using external resistors to set m , such resistors should be as close to the device as possible.

SELECTION OF RESISTORS TO SET m

Internal Matched Resistors

R_A and R_B are matched internal resistors. They are $100\Omega \pm 10\%$, but matched to 0.1%.

(a) $m = 2^*$

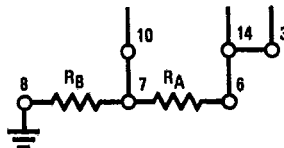

(b) $m = 0.5^*$

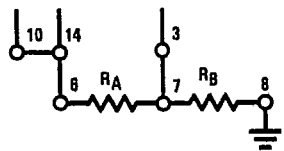

TL/H/5695-2

*No external resistors required, strap as indicated

External Resistors

The exponent is set by 2 external resistors or it may be continuously varied by a single trim pot. ($R_1 + R_2 \leq 500\Omega$).

(a) $m = 1$



TL/H/5695-3

(b) $m < 1$

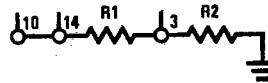

$$m = \frac{R_2}{R_1 + R_2} \quad R_1 + R_2 \approx 200\Omega$$

(c) $m > 1$

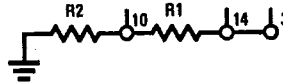

$$m = \frac{R_1 + R_2}{R_2}$$

TL/H/5695-4

ACCURACY (ERROR)

The accuracy of the LH0094 is specified for both externally adjusted and unadjusted cases.

Although it is customary to specify the errors in percent of full-scale (10V), it is seen from the typical performance curves that the actual errors are in percent of reading. Thus, the specified errors are overly conservative for small input voltages. An example of this is the LH0094 used in the multiplication mode. The specified typical error is 0.25% of full-scale (25 mV). As seen from the curve, the unadjusted error is ≈ 25 mV at 10V input, but the error is less than 10 mV for inputs up to 1V. Note also that if either the multiplicand or the multiplier is at less than 10V, (5V for example) the unadjusted error is less. Thus, the errors specified are at full-scale—the worst case.

The LH0094 is designed such that the user is able to externally adjust the gain and offset of the device—thus trim out all of the errors of conversion. In most applications, the gain adjustment is the only external trim needed for super accuracy—except in division mode, where a denominator offset adjust is needed for small denominator voltages.

EXPONENTS

The LH0094 is capable of performing roots to 0.1 and powers up to 10. However, care should be taken when applying these exponent—otherwise, results may be misinterpreted. For example, consider the $1/10$ th power of a number: i.e., 0.001 raised to 0.1 power is 0.5011; 0.1 raised to the 0.1 power is 0.7943; and 10 raised to the 0.1 power is 1.2589. Thus, it is seen that while the input has changed 4 decades, the output has only changed a little more than a factor of 2. It is also seen that with as little as 1 mV of offset, the output will also be greater than zero with zero input.

Applications Information (Continued)

T-73-31

1. CLAMP DIODE CONNECTION

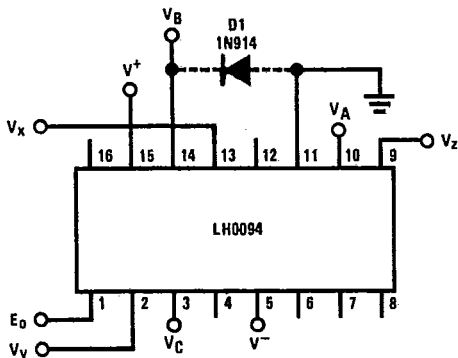

$$E_o = V_y \left(\frac{V_z}{V_x} \right)^m$$

$$0.1 \leq m \leq 10$$

Note: This clamp diode connection is recommended for those applications in which the inputs may be subject to open circuit or negative signals.

FIGURE 1. Clamp Diode Connection

2. MULTIPLY

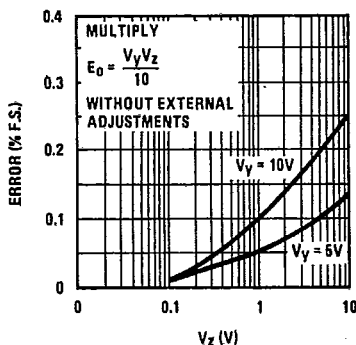
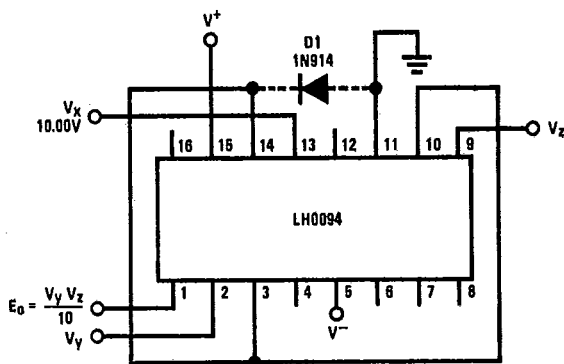
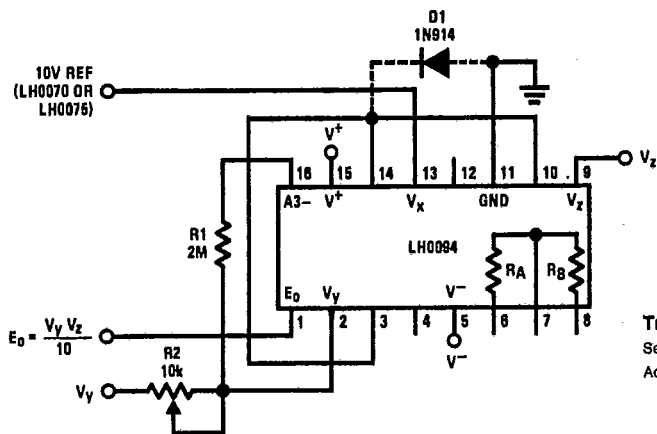

FIGURE 2a. LH0094 Used to Multiply (No External Adjustment)

FIGURE 2b. Typical Performance of LH0094 in Multiply Mode Without External Adjustment



$$E_o = \frac{V_y V_z}{10} \quad m=1$$

Trim Procedure

Set $V_z = V_y = 10V$
Adjust R2 until output = 10.000V

TL/H/5685-5

FIGURE 3. Precision Multiplier (0.02% Typ) with 1 External Adjustment

5

LH0094

T-73-31

Applications Information (Continued)

3. DIVIDE

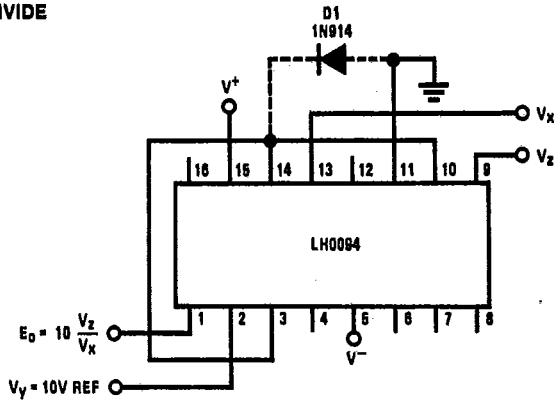

FIGURE 4a. LH0094 Used to Divide (No External Adjustment)

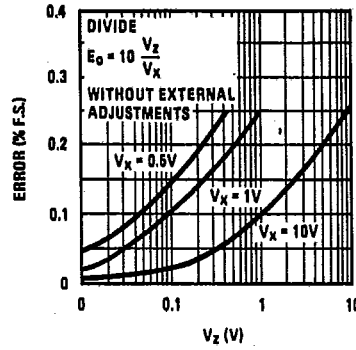

FIGURE 4b. Typical Performance, Divide Mode, Without External Adjustments

Trim Procedures

Apply 10V to V_Y , 0.1V to V_X and V_Z .
Adjust R3 until $E_O \approx 10.000V$.
Apply 10.000V to all inputs.
Adjust R2 until $E_O \approx 10.000V$.
Repeat procedure.

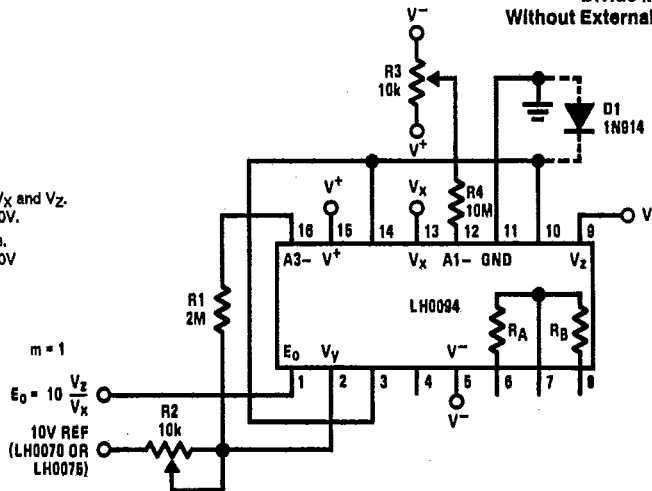

FIGURE 5. Precision Divider (0.05% Typ)

4. SQUARE

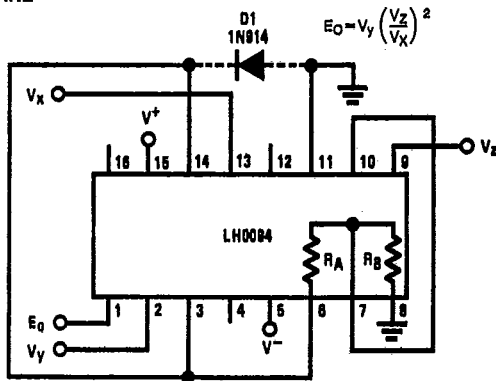

FIGURE 6a. Basic Connection of LH0094 (m = 2) without External Adjustment Using Internal Resistors to Set m

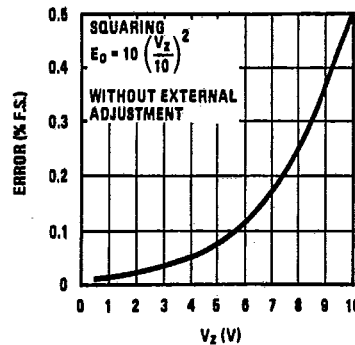

FIGURE 6b. Squaring Mode without External Adjustment

TL/H/5695-8

T-73-31

Applications Information (Continued)

6. LOW LEVEL SQUARE ROOT

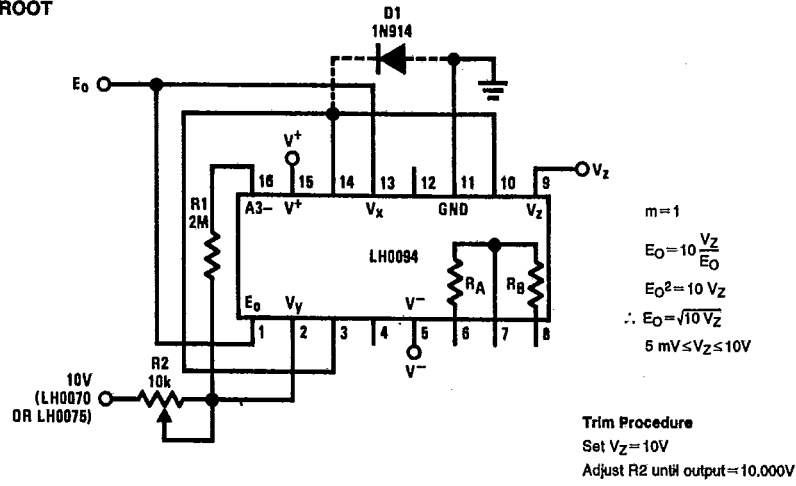

FIGURE 10. 3-Decade Precision Square Root Circuit Using the LH0094 with $m = 1$

Typical Applications

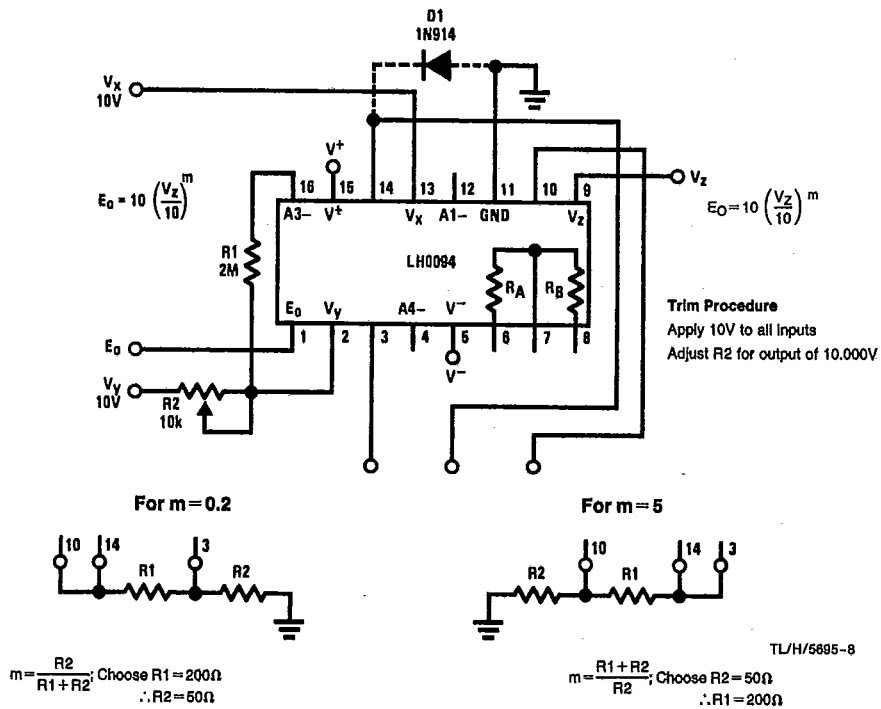
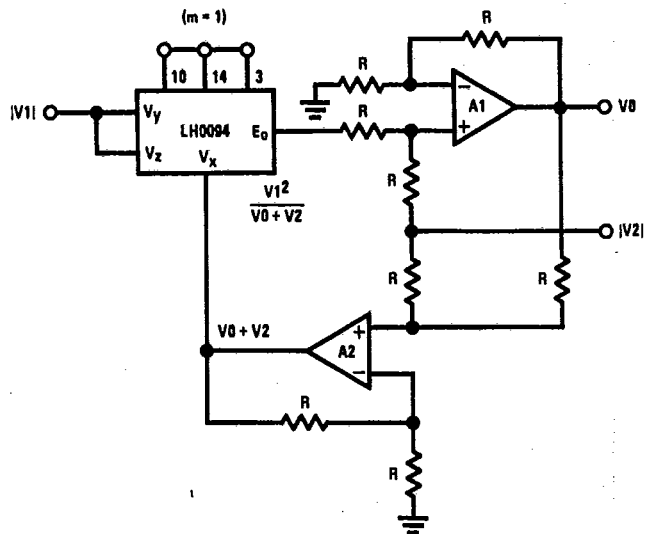

FIGURE 11. Precision Exponentiator ($m = 0.2$ to 5)

LH0094

Typical Applications (Continued)

T-73-31



Note. The LH0094 may be used to generate a voltage equivalent to:

$$V_0 = \sqrt{V_1^2 + V_2^2}$$

$$V_0 = V_2 + \frac{V_1^2}{V_0 + V_2}$$

$$V_0^2 + V_0 V_2 = V_2 V_0 + V_2^2 + V_1^2$$

$$V_0^2 = V_1^2 + V_2^2$$

$$\therefore V_0 = \sqrt{V_1^2 + V_2^2} \quad V_1, V_2 \rightarrow 0 \rightarrow 10V$$

R ≈ 10k

National Semiconductor resistor array RA08—10k is recommended

FIGURE 12. Vector Magnitude Function

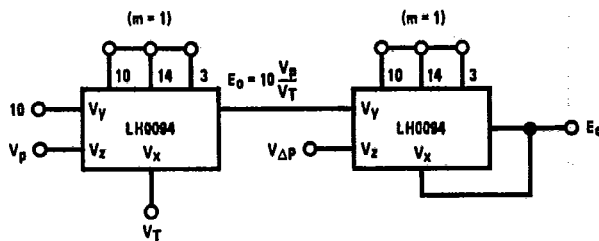

Note. The LH0094 may be used in direct measurement of gas flow.

$$\text{Flow} = k \sqrt{\frac{\Delta P}{T}}$$

$$E_0 = 10 \frac{V_P}{V_T} \times \frac{V_{\Delta P}}{E_0}$$

$$E_0^2 = 10 \frac{V_P V_{\Delta P}}{V_T}$$

$$E_0 = \sqrt{10 \frac{V_P V_{\Delta P}}{V_T}}$$

P = Absolute pressure

T = Absolute temperature

ΔP = Pressure drop

TL/H/5685-8

FIGURE 13. Mass Gas Flow Circuit

5

T-73-31

LH0094

Typical Applications (Continued)

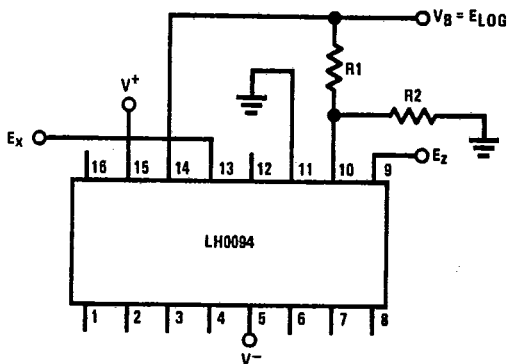
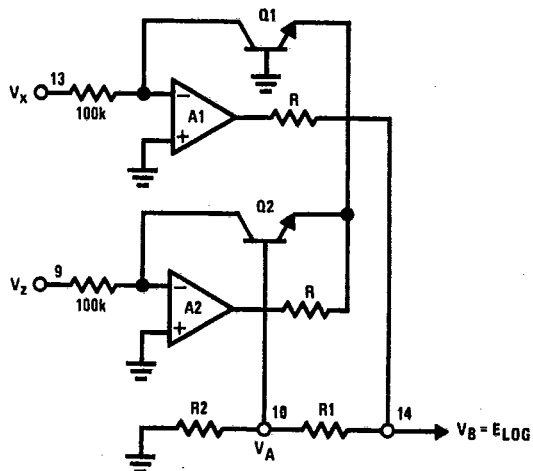

Note. The LH0094 may also be used to generate the Log of a ratio of 2 voltages. The output is taken from pin 14 of the LH0094 for the Log application.

$$E_{LOG} = K1 \frac{KT}{q} \ln \frac{V_z}{V_x}$$

$$\text{where } K1 = \frac{R1 + R2}{R2}$$

$$\text{If } K1 = \frac{1}{KT/q \ln 10}$$

$$\text{then } E_{LOG} = \text{Log}_{10} \frac{V_z}{V_x}$$

$$R1 = 15.9 R2$$

$$R2 \approx 400\Omega$$

R2 must be a thermistor with a tempco of $\approx 0.33\%/^{\circ}\text{C}$ to be compensated over temperature.

FIGURE 14. Log Amp Application

TL/H/5695-10