

SYNCHRONOUS DRAM MODULE

MT4LSDT464A, MT4LSDT864A
MT4LSDT1664A

For the latest data sheet, please refer to the Micron
Web site: www.micron.com/mtl/msp/html/datasheet.html

FEATURES

- PC66-*, PC100- and PC133-compliant
- JEDEC-standard, 168-pin, dual in-line memory module (DIMM)
- Utilizes 100 MHz*, 125 MHz and 133 MHz SDRAM components
- Unbuffered
- 32MB (4 Meg x 64), 64MB (8 Meg x 64), 128MB (16 Meg x 64)
- Single +3.3V ±0.3V power supply
- Fully synchronous; all signals registered on positive edge of system clock
- Internal pipelined operation; column address can be changed every clock cycle
- Internal SDRAM banks for hiding row access/precharge
- Programmable burst lengths: 1, 2, 4, 8 or full page
- Auto Precharge, includes CONCURRENT AUTO PRECHARGE, and Auto Refresh Modes
- Self Refresh Mode
- 64ms, 4,096-cycle refresh
- LVTTTL-compatible inputs and outputs
- Serial Presence-Detect (SPD)

OPTIONS

- Package
168-pin DIMM (gold)
 - Frequency/CAS Latency
133 MHz/CL = 2 (7.5ns, 133 MHz SDRAM) -13E
133 MHz/CL = 3 (7.5ns, 133 MHz SDRAMs) -133
100 MHz/CL = 2 (8ns, 125 MHz SDRAMs) -10E
66 MHz/CL = 2 (10ns, 100 MHz SDRAMs) -662*
- *32MB only

MARKING

G

KEY SDRAM COMPONENT TIMING PARAMETERS

MODULE MARKING	SPEED GRADE	CAS LATENCY	ACCESS TIME	SETUP TIMES	HOLD TIMES
-13E	-7E	2	5.4ns	1.5ns	0.8ns
-133	-75	3	5.4ns	1.5ns	0.8ns
-10E	-8E	2	6ns	2ns	1ns
-662	-10	2	9ns	3ns	1ns

PIN ASSIGNMENT (Front View) 168-Pin DIMM

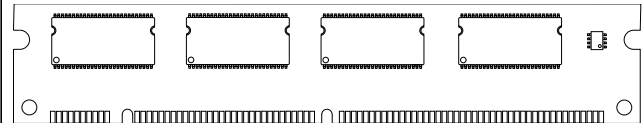

PIN	SYMBOL	PIN	SYMBOL	PIN	SYMBOL	PIN	SYMBOL
1	V _{SS}	43	V _{SS}	85	V _{SS}	127	V _{SS}
2	DQ0	44	DNU	86	DQ32	128	CKE0
3	DQ1	45	S2#	87	DQ33	129	NC (S3#)
4	DQ2	46	DQMB2	88	DQ34	130	DQMB6
5	DQ3	47	DQMB3	89	DQ35	131	DQMB7
6	V _{DD}	48	DNU	90	V _{DD}	132	NC (A13)
7	DQ4	49	V _{DD}	91	DQ36	133	V _{DD}
8	DQ5	50	NC	92	DQ37	134	NC
9	DQ6	51	NC	93	DQ38	135	NC
10	DQ7	52	NC	94	DQ39	136	NC
11	DQ8	53	NC	95	DQ40	137	NC
12	V _{SS}	54	V _{SS}	96	V _{SS}	138	V _{SS}
13	DQ9	55	DQ16	97	DQ41	139	DQ48
14	DQ10	56	DQ17	98	DQ42	140	DQ49
15	DQ11	57	DQ18	99	DQ43	141	DQ50
16	DQ12	58	DQ19	100	DQ44	142	DQ51
17	DQ13	59	V _{DD}	101	DQ45	143	V _{DD}
18	V _{DD}	60	DQ20	102	V _{DD}	144	DQ52
19	DQ14	61	NC	103	DQ46	145	NC
20	DQ15	62	NC	104	DQ47	146	NC
21	NC	63	NC (CKE1)	105	NC	147	NC
22	NC	64	V _{SS}	106	NC	148	V _{SS}
23	V _{SS}	65	DQ21	107	V _{SS}	149	DQ53
24	NC	66	DQ22	108	NC	150	DQ54
25	NC	67	DQ23	109	NC	151	DQ55
26	V _{DD}	68	V _{SS}	110	V _{DD}	152	V _{SS}
27	WE#	69	DQ24	111	CAS#	153	DQ56
28	DQMB0	70	DQ25	112	DQMB4	154	DQ57
29	DQMB1	71	DQ26	113	DQMB5	155	DQ58
30	S0#	72	DQ27	114	NC (S1#)	156	DQ59
31	DNU	73	V _{DD}	115	RAS#	157	V _{DD}
32	V _{SS}	74	DQ28	116	V _{SS}	158	DQ60
33	A0	75	DQ29	117	A1	159	DQ61
34	A2	76	DQ30	118	A3	160	DQ62
35	A4	77	DQ31	119	A5	161	DQ63
36	A6	78	V _{SS}	120	A7	162	V _{SS}
37	A8	79	CK2	121	A9	163	CK3
38	A10	80	NC	122	BA0	164	NC
39	BA1	81	NC/WP**	123	A11	165	SA0
40	V _{DD}	82	SDA	124	V _{DD}	166	SA1
41	V _{DD}	83	SCL	125	CK1	167	SA2
42	CK0	84	V _{DD}	126	NC (A12)	168	V _{DD}

**-133/-10E version only

NOTE: Pin symbols in parentheses are not used on these modules but may be used for other modules in this product family. They are for reference only.

PART NUMBERS

PART NUMBER	CONFIGURATION	SYSTEM BUS SPEED
MT4LSDT464AG-13E__	4 Meg x 64	133MHz
MT4LSDT464AG-133__	4 Meg x 64	133 MHz
MT4LSDT464AG-10E__	4 Meg x 64	100 MHz
MT4LSDT464AG-662__	4 Meg x 64	66 MHz
MT4LSDT864AG-13E__	8 Meg x 64	133 MHz
MT4LSDT864AG-133__	8 Meg x 64	133 MHz
MT4LSDT864AG-10E__	8 Meg x 64	100 MHz
MT4LSDT1664AG-13E__	16 Meg x 64	133 MHz
MT4LSDT1664AG-133__	16 Meg x 64	100 MHz
MT4LSDT1664AG-10E	16 Meg x 64	133 MHz

NOTE: All part numbers end with a two-place code (not shown), designating component and PCB revisions. Consult factory for current revision codes. Example: MT4LSDT464AG-10EB2.

GENERAL DESCRIPTION

The MT4LSDT464A, MT4LSDT864A and MT4LSDT1664A are high-speed CMOS, dynamic random-access, 32MB, 64MB and 128MB memories organized in a x64 configuration. These modules use internally configured quad-bank SDRAMs with a synchronous interface (all signals are registered on the positive edge of the clock signals CK0,CK2).

Read and write accesses to the SDRAM modules are burst oriented; accesses start at a selected location and continue for a programmed number of locations in a programmed sequence. Accesses begin with the registration of an ACTIVE command, which is then followed by a READ or WRITE command. The address bits registered coincident with the ACTIVE command are used to select the bank and row to be accessed (BA0, BA1 select the bank, A0-A11 select the row). The address bits registered coincident with the READ or WRITE command are used to select the starting column location for the burst access.

The modules provide for programmable READ or WRITE burst lengths of 1, 2, 4 or 8 locations, or the full page, with a burst terminate option. An auto precharge function may be enabled to provide a self-timed row precharge that is initiated at the end of the burst sequence.

These modules use an internal pipelined architecture to achieve high-speed operation. This architecture is compatible with the $2n$ rule of prefetch architectures, but it also allows the column address to be changed on every clock cycle to achieve a high-speed, fully random access. Precharging one bank while accessing one of the other three banks will hide the precharge cycles and provide seamless, high-speed, random-access operation.

These modules are designed to operate in 3.3V, low-power memory systems. An auto refresh mode is provided, along with a power-saving, power-down mode. All inputs and outputs are LVTTTL-compatible.

SDRAM modules offer substantial advances in DRAM operating performance, including the ability to syn-chronously burst data at a high data rate with automatic column-address generation, the ability to interleave between internal banks in order to hide precharge time and the capability to randomly change column addresses on each clock cycle during a burst access. For more information regarding SDRAM operation, refer to the 64Mb or 128Mb x4, x8, x16 SDRAM data sheets.

SERIAL PRESENCE-DETECT OPERATION

These modules incorporate serial presence-detect (SPD). The SPD function is implemented using a 2,048-bit EEPROM. This nonvolatile storage device contains 256 bytes. The first 128 bytes can be programmed by Micron to identify the module type and various SDRAM organization and timing parameters. The remaining 128 bytes of storage are available for use by the customer. System READ/WRITE operations between the master (system logic) and the slave EEPROM device (DIMM) occur via a standard IIC bus using the DIMM's SCL (clock) and SDA (data) signals, together with SA(2:0), which provide eight unique DIMM/EEPROM addresses.

**FUNCTIONAL BLOCK DIAGRAM
MT4LSDT464A (32MB)/MT4LSDT864A (64MB)/MT4LSDT1664A (128MB)**

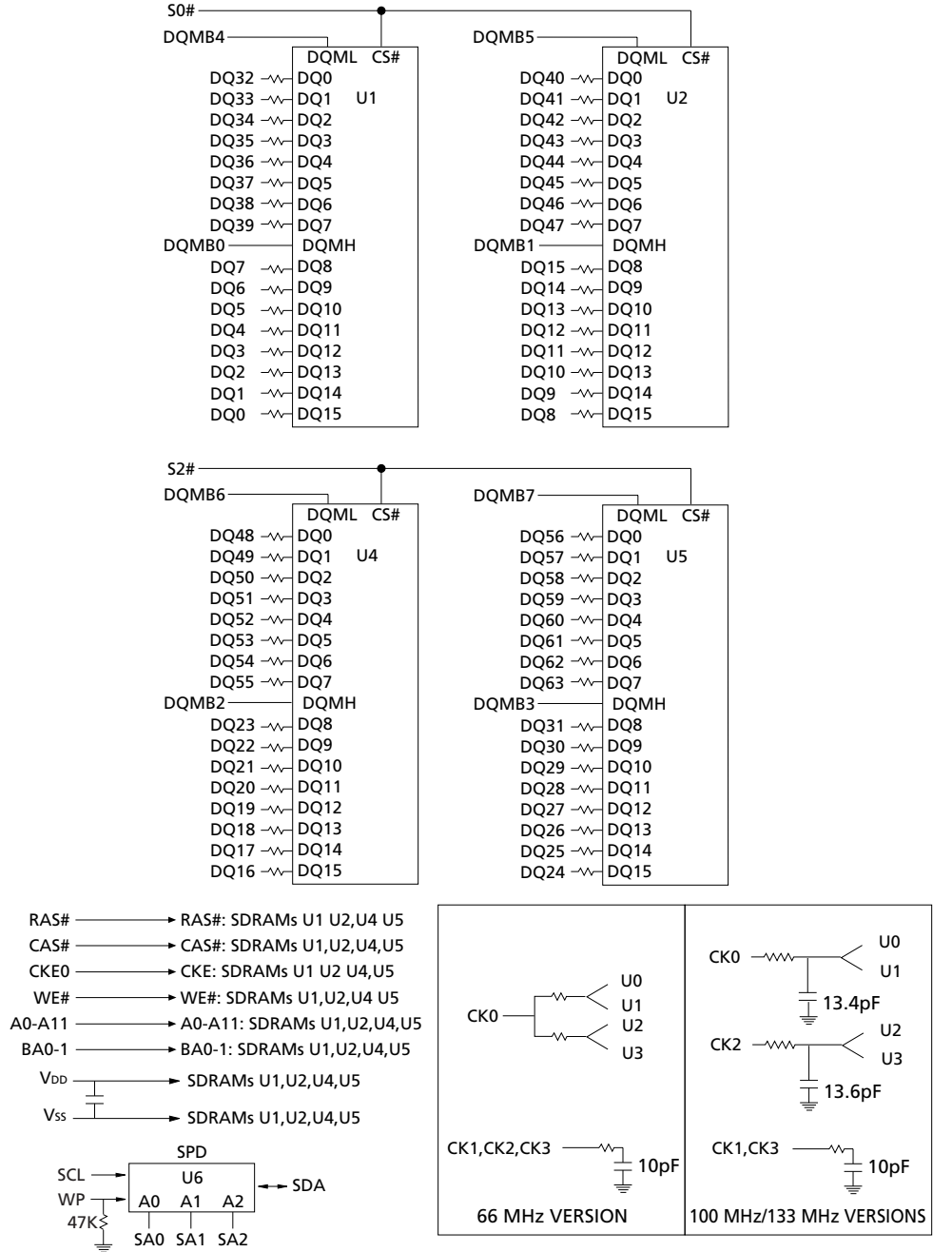

U1, U2, U4, U5 = MT48LC4M16A2TG SDRAMs for 32MB
 U1, U2, U4, U5 = MT48LC8M16A2TG SDRAMs for 64MB
 U1, U2, U4, U5 = MT48LC16M16A2TG SDRAMs for 128MB

NOTE: All resistor values are 10 ohms.

PIN DESCRIPTIONS

PIN NUMBERS	SYMBOL	TYPE	DESCRIPTION
115, 111, 27	RAS#, CAS#, WE#	Input	Command Inputs: RAS#, CAS# and WE# (along with S0#, S2#) define the command being entered.
42, 125, 79, 163	CK0-CK3	Input	Clock: CK0-CK3 are driven by the system clock. All SDRAM input signals are sampled on the positive edge of CK. CK also increments the internal burst counter and controls the output registers.
128	CKE0	Input	Clock Enable: CKE0 activates (HIGH) and deactivates (LOW) the CK0-CK3 signals. Deactivating the clock provides PRECHARGE POWER-DOWN and SELF REFRESH operation (all banks idle), ACTIVE POWER-DOWN (row ACTIVE in any bank), or CLOCK SUSPEND operation (burst access in progress). CKE0 is synchronous except after the device enters power-down and self refresh modes, where CKE0 becomes asynchronous until after exiting the same mode. The input buffers, including CK0-CK3, are disabled during power-down and self refresh modes, providing low standby power.
30, 45	S0#, S2#	Input	Chip Select: S0# and S2# enable (registered LOW) and disable (registered HIGH) the command decoder. All commands are masked when S0# and S2# are registered HIGH. S0# and S2# are considered part of the command code.
28-29, 46-47, 112-113, 130-131	DQMB0-DQMB7	Input	Input/Output Mask: DQMB is an input mask signal for write accesses and an output enable signal for read accesses. Input data is masked when DQMB is sampled HIGH during a WRITE cycle. The output buffers are placed in a High-Z state (two-clock latency) when DQMB is sampled HIGH during a READ cycle.
122, 39	BA0, BA1	Input	Bank Address: BA0 and BA1 define to which bank the ACTIVE, READ, WRITE or PRECHARGE command is being applied.
33, 117, 34, 118, 35, 119, 36, 120, 37, 121, 38, 123, 126	A0-A12	Input	Address Inputs: A0-A12 are sampled during the ACTIVE command (row-address A0-A12) and READ/WRITE command (column-address A0-A7/A8 with A10 defining auto precharge) to select one location out of the memory array in the respective bank. A10 is sampled during a PRECHARGE command to determine if all banks are to be precharged (A10 HIGH) or bank selected by BA0, BA1 (LOW). The address inputs also provide the op-code during a LOAD MODE REGISTER command.
81	WP	Input	Write Protect: Serial presence-detect hardware write protect. Applies to -13E/-133/-10E versions only.
83	SCL	Input	Serial Clock for Presence-Detect: SCL is used to synchronize the presence-detect data transfer to and from the module.

PIN DESCRIPTIONS (continued)

PIN NUMBERS	SYMBOL	TYPE	DESCRIPTION
165-167	SA0-SA2	Input	Presence-Detect Address Inputs: These pins are used to configure the presence-detect device.
2-5, 7-11, 13-17, 19-20, 55-58, 60, 65-67, 69-72, 74-77, 86-89, 91-95, 97-101, 103-104, 139-142, 144, 149-151, 153-156, 158-161	DQ0-DQ63	Input/ Output	Data I/Os: Data bus.
82	SDA	Input/ Output	Serial Presence-Detect Data: SDA is a bidirectional pin used to transfer addresses and data into and data out of the presence-detect portion of the module.
6, 18, 26, 40, 41, 49, 59, 73, 84, 90, 102, 110, 124, 133, 143, 157, 168	V _{DD}	Supply	Power Supply: +3.3V ±0.3V.
1, 12, 23, 32, 43, 54, 64, 68, 78, 85, 96, 107, 116, 127, 138, 148, 152, 162	V _{SS}	Supply	Ground.
31, 44, 48	DNU	–	Do Not Use: These pins are not connected on this module but are assigned pins on the compatible DRAM version.

SPD CLOCK AND DATA CONVENTIONS

Data states on the SDA line can change only during SCL LOW. SDA state changes during SCL HIGH are reserved for indicating start and stop conditions (Figures 1 and 2).

SPD START CONDITION

All commands are preceded by the start condition, which is a HIGH-to-LOW transition of SDA when SCL is HIGH. The SPD device continuously monitors the SDA and SCL lines for the start condition and will not respond to any command until this condition has been met.

SPD STOP CONDITION

All communications are terminated by a stop condition, which is a LOW-to-HIGH transition of SDA when SCL is HIGH. The stop condition is also used to place the SPD device into standby power mode.

SPD ACKNOWLEDGE

Acknowledge is a software convention used to indicate successful data transfers. The transmitting device, either master or slave, will release the bus after transmitting eight bits. During the ninth clock cycle, the receiver will pull the SDA line LOW to acknowledge that it received the eight bits of data (Figure 3).

The SPD device will always respond with an acknowledge after recognition of a start condition and its slave address. If both the device and a WRITE operation have been selected, the SPD device will respond with an acknowledge after the receipt of each subsequent eight bit word. In the read mode the SPD device will transmit eight bits of data, release the SDA line and monitor the line for an acknowledge. If an acknowledge is detected and no stop condition is generated by the master, the slave will continue to transmit data. If an acknowledge is not detected, the slave will terminate further data transmissions and await the stop condition to return to standby power mode.

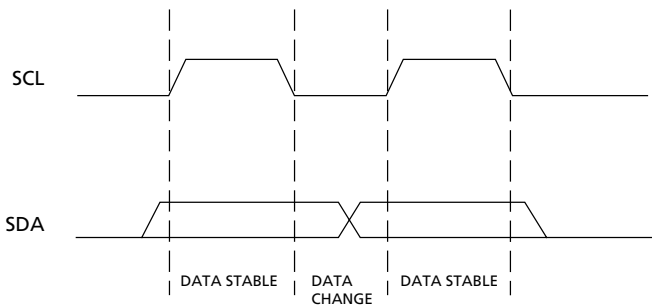

**Figure 1
Data Validity**

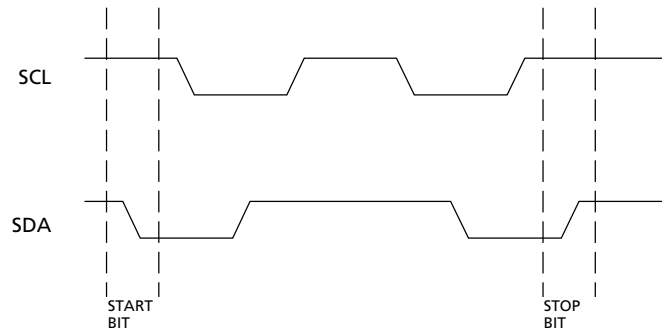

**Figure 2
Definition of Start and Stop**

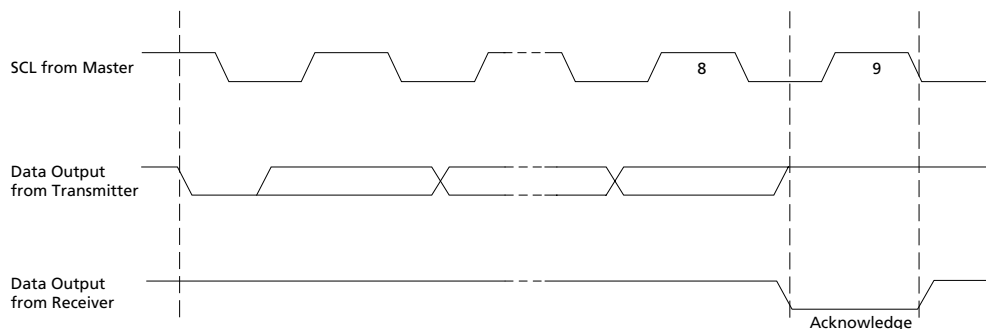

**Figure 3
Acknowledge Response From Receiver**

SERIAL PRESENCE-DETECT MATRIX

BYTE	DESCRIPTION	ENTRY (VERSION)	MT4LSDT464A	MT4LSDT864A	MT4LSDT1664A
0	NUMBER OF BYTES USED BY MICRON	128	80	80	80
1	TOTAL NUMBER OF SPD MEMORY BYTES	256	08	08	08
2	MEMORY TYPE	SDRAM	04	04	04
3	NUMBER OF ROW ADDRESSES	12 or 13	0C	0C	0D
4	NUMBER OF COLUMN ADDRESSES	8 or 9	08	09	09
5	NUMBER OF BANKS	1	01	01	01
6	MODULE DATA WIDTH	64	40	40	40
7	MODULE DATA WIDTH (continued)	0	00	00	00
8	MODULE VOLTAGE INTERFACE LEVELS	LVTTL	01	01	01
9	SDRAM CYCLE TIME, t_{CK} (CAS LATENCY = 3)	7 (-13E) 7.5 (-133) 8 (-10E) 10 (-662)	70 75 80 A0	70 75 80 A0	70 75 80 A0
10	SDRAM ACCESS FROM CLOCK, t_{AC} (CAS LATENCY = 3)	5.4 (-13E/-133) 6 (-10E) 7.5 (-662)	54 60 75	54 60 75	54 60 75
11	MODULE CONFIGURATION TYPE	UNPARITY	00	00	00
12	REFRESH RATE/TYPE	15.6 μ s/SELF	80	80	80
13	SDRAM WIDTH (PRIMARY SDRAM)	16	10	10	10
14	ERROR-CHECKING SDRAM DATA WIDTH	NONE	00	00	00
15	MINIMUM CLOCK DELAY, t_{CCD}	1	01	01	01
16	BURST LENGTHS SUPPORTED	1, 2, 4, 8, PAGE	8F	8F	8F
17	NUMBER OF BANKS ON SDRAM DEVICE	4	04	04	04
18	CAS LATENCIES SUPPORTED	2, 3	06	06	06
19	CS LATENCY	0	01	01	01
20	WE LATENCY	0	01	01	01
21	SDRAM MODULE ATTRIBUTES	UNBUFFERED	00	00	00
22	SDRAM DEVICE ATTRIBUTES: GENERAL	0E	0E	0E	0E
23	SDRAM CYCLE TIME, t_{CK} (CAS LATENCY = 2)	7.5 (-13E) 10 (-133/-10E) 15 (-662)	75 A0 F0	75 A0 F0	75 A0 F0
24	SDRAM ACCESS FROM CK, t_{AC} (CAS LATENCY = 2)	5.4 (-13E) 6 (-133/-10E) 9 (-662)	54 60 90	54 60 90	54 60 90
25	SDRAM CYCLE TIME, t_{CK} (CAS LATENCY = 1)	-	00	00	00
26	SDRAM ACCESS FROM CK, t_{AC} (CAS LATENCY = 1)	-	00	00	00
27	MINIMUM ROW PRECHARGE TIME, t_{RP}	15 (-13E) 20 (-133/-10E) 30 (-662)	0F 14 1E	0F 14 1E	0F 14 1E
28	MINIMUM ROW ACTIVE TO ROW ACTIVE, t_{RRD}	14 (-13E) 15 (-133) 20 (-10E/-662)	0E 0F 14	0E 0F 14	0E 0F 14
29	MINIMUM RAS# TO CAS# DELAY, t_{RCD}	15 (-13E) 20 (-133/-10E) 30 (-662)	0F 14 1E	0F 14 1E	0F 14 1E

NOTE: "1"/"0": Serial Data, "driven to HIGH"/"driven to LOW."

SERIAL PRESENCE-DETECT MATRIX (continued)

BYTE	DESCRIPTION	ENTRY (VERSION)	MT4LSDT464A	MT4LSDT864A	MT4LSDT1664A
30	MINIMUM RAS# PULSE WIDTH, ^t RAS	37 (-13E)	25	25	25
		44 (-133)	2C	2C	2C
		50 (-10E)	32	32	32
		60 (-662)	3C	3C	3C
31	MODULE BANK DENSITY	32MB, 64MB or 128MB	08	10	20
32	COMMAND AND ADDRESS SETUP TIME	1.5 (-13E/-133)	15	15	15
		2 (-10E/-662_2)	20	20	20
		0 (-662_1)	00	00	00
33	COMMAND AND ADDRESS HOLD TIME	0.8 (-13E/-133)	08	08	08
		1 (-10E/-662_2)	10	10	10
		0 (-662_1)	00	00	00
34	DATA SIGNAL INPUT SETUP TIME	1.5 (-13E/-133)	15	15	15
		2 (-10E/-662_2)	20	20	20
		0 (-662_1)	00	00	00
35	DATA SIGNAL INPUT HOLD TIME	0.8 (-13E/-133)	08	08	08
		1 (-10E/-662_2)	10	10	10
		0 (-662_1)	00	00	00
36-61	RESERVED		00	00	00
62	SPD REVISION	1.2 (-13E/-133/-10E/-662_2)	12	12	12
		1.0 (-662_1)	01	01	01
63	CHECKSUM FOR BYTES 0-62	-13E	4E	57	68
		-133	9C	A5	B6
		-10E	E4	ED	FE
		-662_2	B7	C0	D1
		-662_1	46	4F	60
64	MANUFACTURER'S JEDEC ID CODE	MICRON	2C	2C	2C
65-71	MANUFACTURER'S JEDEC ID CODE (continued)		FF	FF	FF
72	MANUFACTURING LOCATION		01	01	01
			02	02	02
			03	03	03
			04	04	04
			05	05	05
			06	06	06
			07	07	07
			08	08	08
			09	09	09
		73-90	MODULE PART NUMBER (ASCII)		x
91	PCB IDENTIFICATION CODE	1	01	01	01
		2	02	02	02
		3	03	03	03
		4	04	04	04
		5	05	05	05
		6	06	06	06
		7	07	07	07
		8	08	08	08
		9	09	09	09
92	IDENTIFICATION CODE (continued)	0	00	00	00
93	YEAR OF MANUFACTURE IN BCD		x	x	x
94	WEEK OF MANUFACTURE IN BCD		x	x	x
95-98	MODULE SERIAL NUMBER		x	x	x

NOTE: 1. "1"/"0": Serial Data, "driven to HIGH"/"driven to LOW."
2. x = Variable Data.

SERIAL PRESENCE-DETECT MATRIX (continued)

BYTE	DESCRIPTION	ENTRY (VERSION)	MT4LSDT464A	MT4LSDT864A	MT4LSDT1664A
99-125	MANUFACTURER-SPECIFIC DATA (RSVD)		–	–	–
126	SYSTEM FREQUENCY	100 MHz (-13E/-133/-10E) 66 MHz (-662)	64 66	64 66	64 66
127	SDRAM COMPONENT AND CLOCK DETAIL	-13E/-133/-10E -662_2 -662_1	AF 8F 06	AF 8F 06	AF 8F 06

- NOTE:** 1. "1"/"0": Serial Data, "driven to HIGH"/"driven to LOW."
2. x = Variable Data.

COMMANDS

Truth Table 1 provides a general reference of available commands. For a more detailed description of commands and operations, refer to the 64Mb,128Mb or 256Mb x4, x8, x16 SDRAM data sheet.

TRUTH TABLE 1 – COMMANDS AND DQMB OPERATION

(Note: 1)

NAME (FUNCTION)	CS#	RAS#	CAS#	WE#	DQMB	ADDR	DQs	NOTES
COMMAND INHIBIT (NOP)	H	X	X	X	X	X	X	
NO OPERATION (NOP)	L	H	H	H	X	X	X	
ACTIVE (Select bank and activate row)	L	L	H	H	X	Bank/Row	X	3
READ (Select bank and column, and start READ burst)	L	H	L	H	L/H ⁸	Bank/Col	X	4
WRITE (Select bank and column, and start WRITE burst)	L	H	L	L	L/H ⁸	Bank/Col	Valid	4
BURST TERMINATE	L	H	H	L	X	X	Active	
PRECHARGE (Deactivate row in bank or banks)	L	L	H	L	X	Code	X	5
AUTO REFRESH or SELF REFRESH (Enter self refresh mode)	L	L	L	H	X	X	X	6, 7
LOAD MODE REGISTER	L	L	L	L	X	Op-Code	X	2
Write Enable/Output enable	–	–	–	–	L	–	Active	8
Write Inhibit/Output High-Z	–	–	–	–	H	–	High-Z	8

- NOTE:**
1. CKE is HIGH for all commands shown except SELF REFRESH.
 2. A0-A12 define the op-code written to the Mode Register.
 3. A0-A12 provide row address, and BA0, BA1 determine which bank is made active.
 4. A0-A7/A8 provide column address; A10 HIGH enables the auto precharge feature (nonpersistent), while A10 LOW disables the auto precharge feature; BA0, BA1 determine which bank is being read from or written to.
 5. A10 LOW: BA0, BA1 determine which bank is being precharged. A10 HIGH: all banks are precharged and BA0, BA1 are "Don't Care."
 6. This command is AUTO REFRESH if CKE is HIGH, SELF REFRESH if CKE is LOW.
 7. Internal refresh counter controls row addressing; all inputs and I/Os are "Don't Care" except for CKE.
 8. Activates or deactivates the DQs during WRITES (zero-clock delay) and READs (two-clock delay).

**Table 1
Burst Definition**

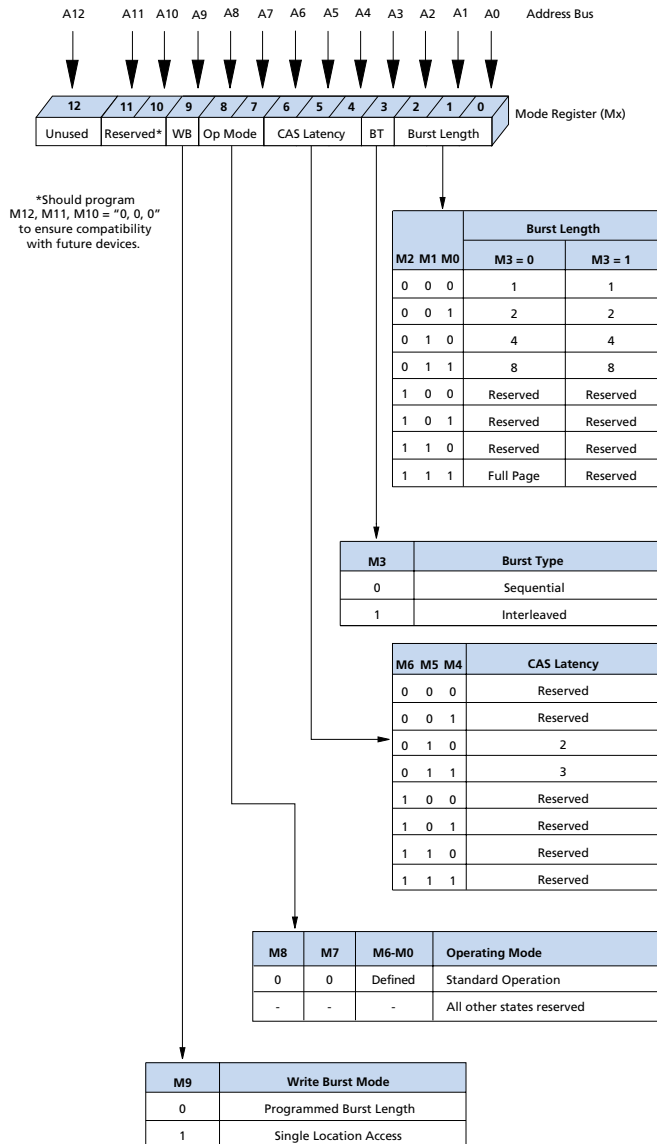

**Figure 4
Mode Register Definition**

Burst Length	Starting Column Address	Order of Accesses Within a Burst	
		Type = Sequential	Type = Interleaved
2	A0		
	0	0-1	0-1
	1	1-0	1-0
4	A1 A0		
	0 0	0-1-2-3	0-1-2-3
	0 1	1-2-3-0	1-0-3-2
	1 0	2-3-0-1	2-3-0-1
	1 1	3-0-1-2	3-2-1-0
8	A2 A1 A0		
	0 0 0	0-1-2-3-4-5-6-7	0-1-2-3-4-5-6-7
	0 0 1	1-2-3-4-5-6-7-0	1-0-3-2-5-4-7-6
	0 1 0	2-3-4-5-6-7-0-1	2-3-0-1-6-7-4-5
	0 1 1	3-4-5-6-7-0-1-2	3-2-1-0-7-6-5-4
	1 0 0	4-5-6-7-0-1-2-3	4-5-6-7-0-1-2-3
	1 0 1	5-6-7-0-1-2-3-4	5-4-7-6-1-0-3-2
	1 1 0	6-7-0-1-2-3-4-5	6-7-4-5-2-3-0-1
1 1 1	7-0-1-2-3-4-5-6	7-6-5-4-3-2-1-0	
Full Page (y)	n = A0-A8/A7 (location 0-y)	Cn, Cn + 1, Cn + 2 Cn + 3, Cn + 4... ...Cn - 1, Cn...	Not supported

- NOTE:**
1. For full-page accesses: y = 512 (64MB/128MB); y = 256 (32MB)
 2. For a burst length of two, A1-A7/A8 select the block-of-two burst; A0 selects the starting column within the block.
 3. For a burst length of four, A2-A7/A8 select the block-of-four burst; A0-A1 select the starting column within the block.
 4. For a burst length of eight, A3-A7/A8 select the block-of-eight burst; A0-A2 select the starting column within the block.
 5. For a full-page burst, the full row is selected, and A0-A7/A8 select the starting column.
 6. Whenever a boundary of the block is reached within a given sequence above, the following access wraps within the block.
 7. For a burst length of one, A0-A7/A8 select the unique column to be accessed, and Mode Register bit M3 is ignored.

ABSOLUTE MAXIMUM RATINGS*

Voltage on V_{DD} Supply Relative to V_{SS} .. -1V to +4.6V
 Voltage on Inputs, NC or I/O Pins
 Relative to V_{SS} -1V to +4.6V
 Operating Temperature, T_A (ambient) .. 0°C to +70°C
 Storage Temperature (plastic) -55°C to +125°C
 Power Dissipation 4W

*Stresses greater than those listed under “Absolute Maximum Ratings” may cause permanent damage to the device. This is a stress rating only, and functional operation of the device at these or any other conditions above those indicated in the operational sections of this specification is not implied. Exposure to absolute maximum rating conditions for extended periods may affect reliability.

DC ELECTRICAL CHARACTERISTICS AND OPERATING CONDITIONS

 (Notes: 1, 2) (V_{DD} = +3.3V ±0.3V)

PARAMETER/CONDITION	SYMBOL	MIN	MAX	UNITS	NOTES	
SUPPLY VOLTAGE	V _{DD}	3	3.6	V		
INPUT HIGH VOLTAGE: Logic 1; All inputs	V _{IH}	2	V _{DD} + 0.3	V	3	
INPUT LOW VOLTAGE: Logic 0; All inputs	V _{IL}	-0.5	0.8	V	3	
INPUT LEAKAGE CURRENT: Any input 0V ≤ V _{IN} ≤ V _{DD} (All other pins not under test = 0V)	DQMB0-DQMB7	I _{I1}	-5	5	μA	
	CK0, CK2, S0#, S2#	I _{I2}	-10	10	μA	4
	CKE0, RAS#, CAS#, A0-A2, BA0-BA1, WE#	I _{I3}	-20	20	μA	
OUTPUT LEAKAGE CURRENT: DQs are disabled; 0V ≤ V _{OUT} ≤ V _{DD}	DQ0-DQ63	I _{OZ}	-5	5	μA	
OUTPUT LEVELS: Output High Voltage (I _{OUT} = -4mA) Output Low Voltage (I _{OUT} = 4mA)	V _{OH}	2.4	-	V		
	V _{OL}	-	0.4	V		

- NOTE:**
- All voltages referenced to V_{SS}.
 - An initial pause of 100μs is required after power-up, followed by two AUTO REFRESH commands, before proper device operation is ensured. The two AUTO REFRESH command wake-ups should be repeated any time the 'REF refresh requirement is exceeded.
 - V_{IH} overshoot: V_{IH} (MAX) = V_{DD} + 2V for a pulse width ≤ 10ns, and the pulse width cannot be greater than one third of the cycle rate. V_{IL} undershoot: V_{IL} (MIN) = -2V for a pulse width ≤ 10ns, and the pulse width cannot be greater than one third of the cycle rate.
 - CK0 = 20mA for 66 MHz versions.

I_{DD} SPECIFICATIONS AND CONDITIONS

 (Notes: 1-4) ($V_{DD} = +3.3V \pm 0.3V$)

PARAMETER/CONDITION	SYMBOL	SIZE	MAX				UNITS	NOTES	
			-13E	-133	-10E	-662			
OPERATING CURRENT: Active Mode; Burst = 2; READ or WRITE; $t_{RC} = t_{RC}(\text{MIN})$; CAS latency = 3	I _{DD1} 64MB	32MB	500	460	380	360	mA	5, 6, 7, 8	
		64MB	600	560	n/a				
		128MB	TBD	TBD	TBD	n/a			
STANDBY CURRENT: Power-Down Mode; CKE = LOW; All banks idle	I _{DD2}	32MB	8	8	8	12	mA	8	
		64MB	8	8	8	n/a			
		128MB	8	8	8	n/a			
STANDBY CURRENT: Active Mode; S0#, S2# = HIGH; CKE = HIGH; All banks active after t_{RCD} met; No accesses in progress	I _{DD3}	32MB	180	180	140	120	mA	5, 7, 8, 9	
		64MB	200	200	160	n/a			
		128MB	220	200	160	n/a			
OPERATING CURRENT: Burst Mode; Continuous burst; READ or WRITE; All banks active; CAS latency = 3	I _{DD4}	32MB	600	560	480	420	mA	5, 6, 7, 8	
		64MB	660	600	560	n/a			
		128MB	TBD	TBD	TBD	n/a			
AUTO REFRESH CURRENT: CKE = HIGH; S0#, S2# = HIGH	I _{DD5}	$t_{RC} = t_{RC}(\text{MIN})$; CL = 3	32MB	920	840	760	680	mA	5, 6, 7, 9
			64MB	1,320	1,240	1,080	n/a		
			128MB	TBD	TBD	TBD	n/a		
	I _{DD6}	$t_{RC} = 15.625\mu\text{s}$; CL = 3	32MB	12	12	12	12	mA	8 10
			64MB	12	12	12	n/a		
			128MB	16	16	16	n/a		
SELF REFRESH CURRENT: CKE $\leq 0.2V$	I _{DD7}	32MB	4	4	4	8	mA	11	
		64MB	8	8	8	n/a			
		128MB	TBD	8	8	n/a			

- NOTE:**
- All voltages referenced to V_{SS} .
 - An initial pause of 100 μs is required after power-up, followed by two AUTO REFRESH commands, before proper device operation is ensured. The two AUTO REFRESH command wake-ups should be repeated any time the t_{REF} refresh requirement is exceeded.
 - AC timing and I_{DD} tests have $V_{IL} = 0V$ and $V_{IH} = 3V$, with timing referenced to 1.5V crossover point.
 - I_{DD} specifications are tested after the device is properly initialized.
 - I_{DD} is dependent on output loading and cycle rates. Specified values are obtained with minimum cycle time and the outputs open.
 - The I_{DD} current will decrease as the CAS latency is reduced. This is due to the fact that the maximum cycle rate is slower as the CAS latency is reduced.
 - Address transitions average one transition every two clocks.
 - $t_{CK} = 7.5\text{ns}$ for -13E/-133; $t_{CK} = 10\text{ns}$ for -10E; $t_{CK} = 15\text{ns}$ for -662.
 - Other input signals are allowed to transition no more than once in any two-clock period and are otherwise at valid V_{IH} or V_{IL} levels.
 - CKE is HIGH during refresh command period ($t_{RFC}[\text{MIN}]$) else CKE is LOW. The I_{DD_g} limit is actually a nominal value and does not result in a fail value.
 - Enables on-chip refresh and address counters.

CAPACITANCE

(Note: 1)

PARAMETER	SYMBOL	MIN	MAX	UNITS	NOTES
Input Capacitance: A0-A12, BA0, BA1, RAS#, CAS#, WE#, CKE0	C _{i1}	12	18	pF	
Input Capacitance: CK0-CK3	C _{i2}	25	29	pF	2
Input Capacitance: S0#, S2#	C _{i3}	6	10	pF	
Input Capacitance: DQMB0#-DQMB7#	C _{i4}	4	6	pF	
Input Capacitance: SCL, SA0-SA2, SDA, WP	C _{i01}	–	10	pF	
Input/Output Capacitance: DQ0-DQ63	C _{i02}	6	8	pF	

- NOTE:**
1. This parameter is sampled. $V_{DD} = +3.3V$; $f = 1$ MHz.
 2. Values shown include added loading capacitance for 66 MHz, CK0 = 12pF (MIN), 16pF (MAX).

SDRAM COMPONENT* AC ELECTRICAL CHARACTERISTICS

(Notes: 1-5)

AC CHARACTERISTICS			-13E (PC133)		-133 (PC133)		-10E (PC100)		-662 (PC66)			
PARAMETER		SYMBOL	MIN	MAX	MIN	MAX	MIN	MAX	MIN	MAX	UNITS	NOTES
Access time from CK (pos. edge)	CL = 3	t_{AC}		5.4		5.4		6		7.5	ns	
	CL = 2	t_{AC}		5.4		6		6		9	ns	
Address hold time		t_{AH}	0.8		0.8		1		1		ns	
Address setup time		t_{AS}	1.5		1.5		2		2		ns	
CK high-level width		t_{CH}	2.5		2.5		3		3		ns	
CK low-level width		t_{CL}	2.5		2.5		3		3		ns	
Clock cycle time	CL = 3	t_{CK}	7		7.5		8		10		ns	6
	CL = 2	t_{CK}	7.5		10		10		15		ns	6
CKE hold time		t_{CKH}	0.8		0.8		1		1		ns	
CKE setup time		t_{CKS}	1.5		1.5		2		2		ns	
CS#, RAS#, CAS#, WE#, DQM hold time		t_{CMH}	0.8		0.8		1		1		ns	
CS#, RAS#, CAS#, WE#, DQM setup time		t_{CMS}	1.5		1.5		2		2		ns	
Data-in hold time		t_{DH}	0.8		0.8		1		1		ns	
Data-in setup time		t_{DS}	1.5		1.5		2		2		ns	
Data-out high-impedance time	CL = 3	t_{HZ}		5.4		5.4		6		8	ns	7
	CL = 2	t_{HZ}		5.4		6		7		10	ns	7
Data-out low-impedance time		t_{LZ}	1		1		1		2		ns	
Data-out hold time (load)		t_{OH}	2.7		2.7		3		3		ns	
Data-out hold time (no load)		t_{OH_N}	1.8		1.8		1.8		n/a		ns	8
ACTIVE to PRECHARGE command		t_{RAS}	37	120,000	44	120,000	50	120,000	60	120,000	ns	
ACTIVE to ACTIVE command period		t_{RC}	60		66		70		90		ns	
ACTIVE to READ or WRITE delay		t_{RCD}	15		20		20		30		ns	
Refresh period (4,096 cycles)		t_{REF}		64		64		64		64	ms	
AUTO REFRESH period		t_{RFC}	66		66		70		90		ns	
PRECHARGE command period		t_{RP}	15		20		20		30		ns	
ACTIVE bank A to ACTIVE bank B command		t_{RRD}	14		15		20		20		ns	
Transition time		t_T	0.3	1.2	0.3	1.2	0.3	1.2	1	1.2	ns	9
WRITE recovery time		t_{WR}	CK + 7ns		1 CK + 7.5ns		1 CK + 7ns		1 CK + 7ns		-	10
			14		15		15		15		ns	11
Exit SELF REFRESH to ACTIVE command		t_{XSR}	67		75		80		90		ns	12

*Specifications for the SDRAM components used on the module.

- NOTE:**
- The minimum specifications are used only to indicate cycle time at which proper operation over the full temperature range ($0^{\circ}\text{C} \leq T_A \leq +70^{\circ}\text{C}$) is ensured.
 - An initial pause of 100 μs is required after power-up, followed by two AUTO REFRESH commands, before proper device operation is ensured. The two AUTO REFRESH command wake-ups should be repeated any time the t_{REF} refresh requirement is exceeded.
 - In addition to meeting the transition rate specification, the clock and CKE must transit between V_{IH} and V_{IL} (or between V_{IL} and V_{IH}) in a monotonic manner.
 - Outputs measured at 1.5V with equivalent load:

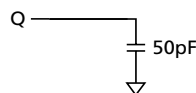

- AC timing and I_{DD} tests have $V_{IL} = 0\text{V}$ and $V_{IH} = 3\text{V}$, with timing referenced to 1.5V crossover point.

NOTES: (continued)

6. The clock frequency must remain constant during access or precharge states (READ, WRITE, including ^tWR, and PRECHARGE commands). CKE may be used to reduce the data rate.
7. ^tHZ defines the time at which the output achieves the open circuit condition; it is not a reference to V_{OH} or V_{OL}. The last valid data element will meet ^tOH before going High-Z.
8. Parameter guaranteed by design.
9. AC characteristics assume ^tT = 1ns.
10. Auto precharge mode only. The precharge timing budget (^tRP) begins 7.5ns/7ns after the first clock delay, after the last WRITE is executed.
11. Precharge mode only.
12. CK must be toggled a minimum of two times during this period.

AC FUNCTIONAL CHARACTERISTICS

(Notes: 1-5)

PARAMETER	SYMBOL	-133	-13E/-10E	-662	UNITS	NOTES
READ/WRITE command to READ/WRITE command	t_{CCD}	1	1	1	t_{CK}	6
CKE to clock disable or power-down entry mode	t_{CKED}	1	1	1	t_{CK}	7
CKE to clock enable or power-down exit setup mode	t_{PED}	1	1	1	t_{CK}	7
DQM to input data delay	t_{DQD}	0	0	0	t_{CK}	6
DQM to data mask during WRITES	t_{DQM}	0	0	0	t_{CK}	6
DQM to data high-impedance during READs	t_{DQZ}	2	2	2	t_{CK}	11
WRITE command to input data delay	t_{DWD}	0	0	0	t_{CK}	6
Data-in to ACTIVE command	t_{DAL}	5	4	4	t_{CK}	8, 9
Data-in to PRECHARGE command	t_{DPL}	2	2	2	t_{CK}	9, 10
Last data-in to burst STOP command	t_{BDL}	1	1	1	t_{CK}	6
Last data-in to new READ/WRITE command	t_{CDL}	1	1	1	t_{CK}	6
Last data-in to PRECHARGE command	t_{RDL}	2	2	2	t_{CK}	9, 10
LOAD MODE REGISTER command to ACTIVE or REFRESH command	t_{MRD}	2	2	2	t_{CK}	12
Data-out to high-impedance from PRECHARGE command	CL = 3	t_{ROH}	3	3	t_{CK}	6
	CL = 2	t_{ROH}	2	2	t_{CK}	6

- NOTE:**
1. The minimum specifications are used only to indicate cycle time at which proper operation over the full temperature range ($0^{\circ}\text{C} \leq T_A \leq +70^{\circ}\text{C}$) is ensured.
 2. An initial pause of 100 μs is required after power-up, followed by two AUTO REFRESH commands, before proper device operation is ensured. The two AUTO REFRESH command wake-ups should be repeated any time the 'REF refresh requirement is exceeded.
 3. In addition to meeting the transition rate specification, the clock and CKE must transit between V_{IH} and V_{IL} (or between V_{IL} and V_{IH}) in a monotonic manner.
 4. Outputs measured at 1.5V with equivalent load:

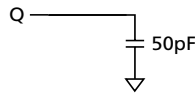

5. AC timing and I_{DD} tests have $V_{IL} = 0\text{V}$ and $V_{IH} = 3\text{V}$, with timing referenced to 1.5V crossover point.
6. Required clocks are specified by JEDEC functionality and are not dependent on any timing parameter.
7. Timing actually specified by t_{CKS} ; clock(s) specified as a reference only at minimum cycle rate.
8. Timing actually specified by t_{WR} plus t_{RP} ; clock(s) specified as a reference only at minimum cycle rate.
9. Based on $t_{CK} = 133\text{ MHz}$ for -13E/-133, 100 MHz for -10E and 66 MHz for -662.
10. Timing actually specified by t_{WR} .
11. Required clocks are specified by JEDEC functionality and are not dependent on any timing parameter.
12. JEDEC and PC100 specify three clocks.

SERIAL PRESENCE-DETECT EEPROM DC OPERATING CONDITIONS

 (Note: 1) ($V_{DD} = +3.3V \pm 0.3V$)

PARAMETER/CONDITION	SYMBOL	MIN	MAX	UNITS	NOTES
SUPPLY VOLTAGE	V_{DD}	3	3.6	V	
INPUT HIGH VOLTAGE: Logic 1; All inputs	V_{IH}	$V_{DD} \times 0.7$	$V_{DD} + 0.5$	V	
INPUT LOW VOLTAGE: Logic 0; All inputs	V_{IL}	-1	$V_{DD} \times 0.3$	V	
OUTPUT LOW VOLTAGE: $I_{OUT} = 3mA$	V_{OL}	-	0.4	V	
INPUT LEAKAGE CURRENT: $V_{IN} = GND$ to V_{DD}	I_{LI}	-	10	μA	
OUTPUT LEAKAGE CURRENT: $V_{OUT} = GND$ to V_{DD}	I_{LO}	-	10	μA	
STANDBY CURRENT: SCL = SDA = $V_{DD} - 0.3V$; All other inputs = GND or $3.3V + 10\%$	I_{SB}	-	30	μA	
POWER SUPPLY CURRENT: SCL clock frequency = 100 KHz	I_{DD}	-	2	mA	

NOTE: 1. All voltages referenced to V_{SS} .

SERIAL PRESENCE-DETECT EEPROM AC OPERATING CONDITIONS

 (Notes: 1) ($V_{DD} = +3.3V \pm 0.3V$)

PARAMETER/CONDITION	SYMBOL	MIN	MAX	UNITS	NOTES
SCL LOW to SDA data-out valid	t_{AA}	0.3	3.5	μs	
Time the bus must be free before a new transition can start	t_{BUF}	4.7		μs	
Data-out hold time	t_{DH}	300		ns	
SDA and SCL fall time	t_F		300	ns	
Data-in hold time	$t_{HD:DAT}$	0		μs	
Start condition hold time	$t_{HD:STA}$	4		μs	
Clock HIGH period	t_{HIGH}	4		μs	
Noise suppression time constant at SCL, SDA inputs	t_I		100	ns	
Clock LOW period	t_{LOW}	4.7		μs	
SDA and SCL rise time	t_R		1	μs	
SCL clock frequency	t_{SCL}		100	KHz	
Data-in setup time	$t_{SU:DAT}$	250		ns	
Start condition setup time	$t_{SU:STA}$	4.7		μs	
Stop condition setup time	$t_{SU:STO}$	4.7		μs	
WRITE cycle time	t_{WRC}		10	ms	2

NOTE: 1. All voltages referenced to V_{SS} .

 2. The SPD EEPROM WRITE cycle time (t_{WRC}) is the time from a valid stop condition of a WRITE sequence to the end of the EEPROM internal erase/program cycle. During the WRITE cycle, the EEPROM bus interface circuit is disabled, SDA remains HIGH due to pull-up resistor, and the EEPROM does not respond to its slave address.

SPD EEPROM

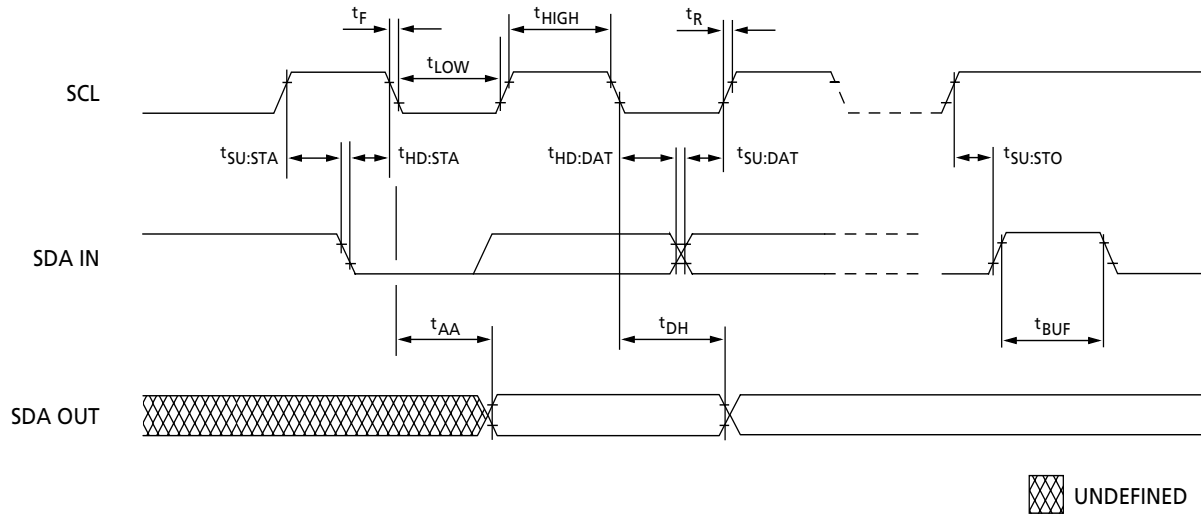

**SERIAL PRESENCE-DETECT EEPROM
TIMING PARAMETERS**

SYMBOL	MIN	MAX	UNITS
t_{AA}	0.3	3.5	μs
t_{BUF}	4.7		μs
t_{DH}	300		ns
t_F		300	ns
$t_{HD:DAT}$	0		μs
$t_{HD:STA}$	4		μs

SYMBOL	MIN	MAX	UNITS
t_{HIGH}	4		μs
t_{LOW}	4.7		μs
t_R		1	μs
$t_{SU:DAT}$	250		ns
$t_{SU:STA}$	4.7		μs
$t_{SU:STO}$	4.7		μs

168-PIN DIMM

FRONT VIEW

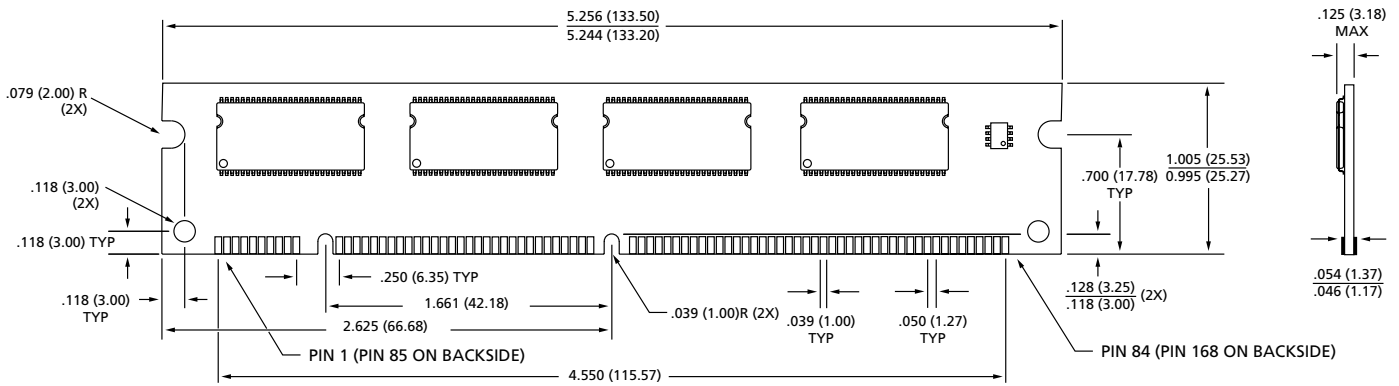

NOTE: All dimensions in inches (millimeters) $\frac{\text{MAX}}{\text{MIN}}$ or typical where noted.



8000 S. Federal Way, P.O. Box 6, Boise, ID 83707-0006, Tel: 208-368-3900

E-mail: prodmtg@micron.com, Internet: <http://www.micron.com>, Customer Comment Line: 800-932-4992

Micron is a registered trademark of Micron Technology, Inc.



| PART SELECTOR | PART NUMBERING GUIDES | ORDER INFORMATION |

DRAM Modules

SDRAM Modules

DDR SDRAM Modules

RIMM™ Modules

| ORDER INFORMATION |

For more information about our high-quality Micron® Modules, visit our Web site or phone us today.



www.micron.com/mti



208.368.3900

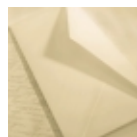

Micron Semiconductor Products, Inc.

8000 S. Federal Way, P.O. Box 6 • Boise, Idaho 83707-0006 • Tel: 208-368-3900 • Fax: 208-368-4617
Internet: www.micron.com/mti • E-mail: prodmtg@micron.com
Customer Comment Line: 800-932-4992 • Customer Comment Fax Line: 01-208-368-5018

Micron Europe Limited

Micron House, Wellington Business Park • Dukes Ride, Crowthorne • Berkshire RG45 6LS • United Kingdom
Tel: 44-1344-750750 • Fax: 44-1344-750710

Micron Semiconductor (Deutschland) GmbH

Sternstrasse 20 • D-85609 Aschheim • Germany • Tel: 49-89-904-8720 • Fax: 49-89-904-87250

Micron Semiconductor Asia, Pte. Ltd.

5 Upper Aljunied Link #06-06 • Quartz Industrial Bldg. • Singapore 367903 • Tel: 65-287-6006 • Fax: 65-287-6556

Micron Technology Asia Pacific, Inc., Taiwan Branch

Suite 1010, 10th Floor • 333 Keelung Road, Sec 1 • Taipei, 110 Taiwan, ROC • Tel: 886-2-2757-6622 • Fax: 886-2-2757-6656

Micron Technology Italia, Srl

Via Antonio Pacinotti 5/7 • Nucleo Industriale (AQ), Building 2 • Avezzano (AQ) Italia 67051 • Tel: 39-0863-423206 • Fax: 39-0863-423283

Micron Technology Japan, K.K.

4-30 Shiba-Koen 3-chome • 32 Mori Building 8F • Minato-ku • Tokyo 105, Japan • Tel: 81-3-3436-5666 • Fax: 81-3-3436-1444



©2000, Micron Technology, Inc.

Micron is a registered trademark of Micron Technology, Inc.
Intel is a registered trademark of Intel Corporation. Rambus and RDRAM are registered trademarks and RIMM is a trademark of Rambus Inc. Products and specifications are subject to change without notice.

Rev. 3/00



DRAM MODULE NUMBERING

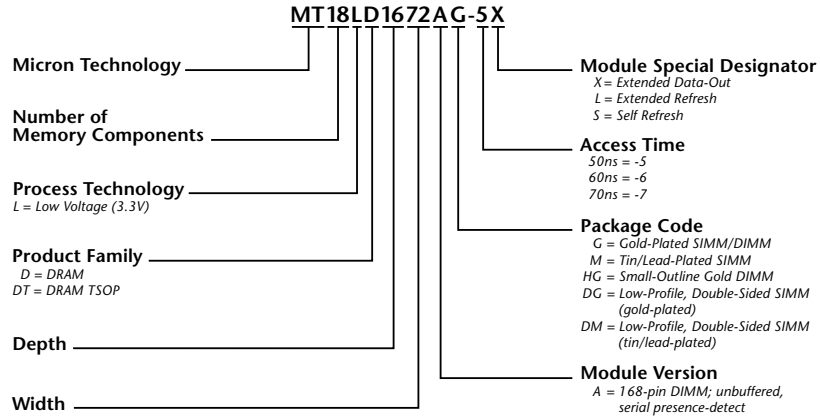

SDRAM/RDRAM® MODULE NUMBERING

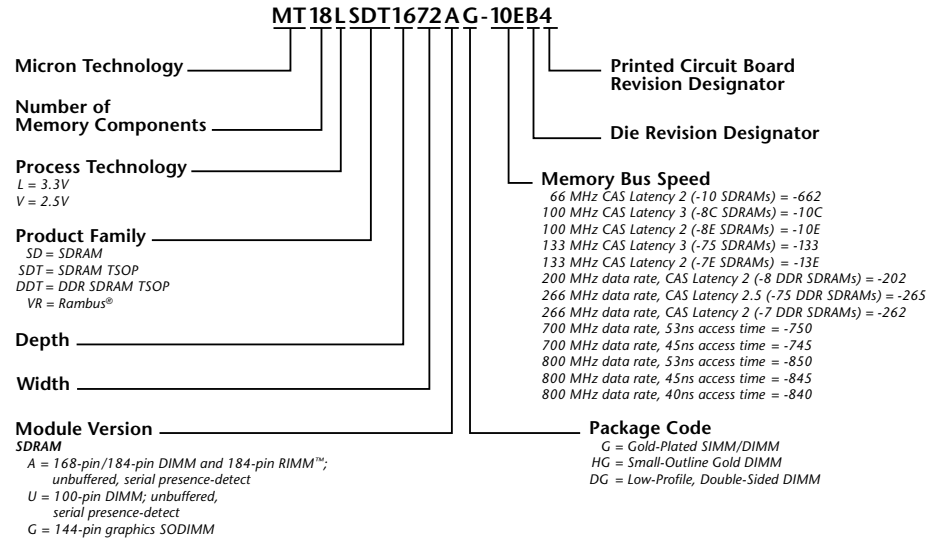

DRAM MODULE PART SELECTOR

Data sheets are available at
www.micron.com/mti/msp/html/modds.html.



MODULE KEY

DS = Double Sided, **SS** = Single Sided; **M** = Tin Plated, **G** = Gold Plated; **U** = 100-pin DIMM, **H** = Small-Outline DIMM (SODIMM), **(A)** = see footnote references below, **(X)** = EDO, no **X** = FPM version

DRAM MODULES

Family	Density	Description	Module Components	Module Part Number	Speed	Height	Sample	Prod.
72-pin SODIMM	4MB	SS 1 Meg x 32 3.3V Gold	(2) 1 Meg x 16 TSOP	MT2LDT132HG (X)	60	1.000"	Now	Now
	8MB	SS 2 Meg x 32 3.3V Gold	(4) 1 Meg x 16 TSOP	MT4LDT232HG (X)	60	1.000"	Now	Now
	16MB	SS 4 Meg x 32 3.3V Gold	(2) 4 Meg x 16 TSOP	MT2LDT432HG (X)	60	1.000"	Now	Now
	16MB	DS 4 Meg x 32 3.3V Gold	(8) 4 Meg x 4 TSOP	MT8LDT432HG (X)	60	1.000"	Now	Now
	32MB	DS 8 Meg x 32 3.3V Gold	(4) 4 Meg x 16 TSOP	MT4LDT832HG (X)	60	1.000"	Now	Now
72-pin SIMM	4MB	SS 1 Meg x 32 Gold/Tin	(2) 1 Meg x 16	MT2D132G/M (X)	50, 60	.800"	Now	Now
	8MB	DS 2 Meg x 32 Gold/Tin	(4) 1 Meg x 16	MT4D232DG/M (X)	50, 60	.800"	Now	Now
	16MB	SS 4 Meg x 32 Gold/Tin	(8) 4 Meg x 4	MT8D432G/M (X)	50, 60	1.000"	Now	Now
	16MB	SS 4 Meg x 36 ECC Gold/Tin	(9) 4 Meg x 4	MT9D436G/M (X)	50, 60	1.000"	Now	Now
	32MB	DS 8 Meg x 36 ECC Gold/Tin	(18) 4 Meg x 4	MT18D836G/M (X)	50, 60	1.000"	Now	Now
	32MB	DS 8 Meg x 32 Gold/Tin	(16) 4 Meg x 4	MT16D832G/M (X)	50, 60	1.000"	Now	Now
100-pin DIMM	4MB	SS 1 Meg x 32 3.3V Gold	(2) 1 Meg x 16	MT2LD132UG (X)	60	1.000"	Now	Now
	8MB	SS 2 Meg x 32 3.3V Gold	(4) 1 Meg x 16	MT4LD232UG (X)	60	1.000"	Now	Now
	16MB	SS 4 Meg x 32 3.3V Gold	(2) 4 Meg x 16 TSOP	MT2LDT432UG (X)	60	1.000"	Now	Now
	32MB	DS 8 Meg x 32 3.3V Gold	(4) 4 Meg x 16 TSOP	MT4LDT832UG (X)	60	1.000"	Now	Now
144-pin SODIMM	32MB	DS 4 Meg x 64 3.3V Gold	(4) 4 Meg x 16 TSOP	MT4LDT464HG (X)(S)	50, 60	1.000"	Now	Now
	64MB	DS 8 Meg x 64 3.3V Gold	(8) 8 Meg x 8 TSOP	MT8LDT864HG (X)(S)	60	1.050"	Now	Now
168-pin DIMM	8MB	DS 1 Meg x 64 3.3V Gold	(4) 1 Meg x 16 TSOP	MT4LDT164AG (X)	60	1.000"	Now	Now
	32MB	SS 4 Meg x 64 3.3V Gold	(4) 4 Meg x 16 TSOP	MT4LDT464AG (X)	50, 60	1.000"	Now	Now
	32MB	DS 4 Meg x 64 3.3V Gold	(16) 4 Meg x 4	MT16LD464AG (X)	60	1.000"	Now	Now
	32MB	DS 4 Meg x 72 3.3V ECC Gold	(18) 4 Meg x 4	MT18LD472(A)G (X)	60	UB = 1.000" B = 1.000"	Now	Now
	32MB	SS 4 Meg x 72 3.3V ECC Gold	(5) 4 Meg x 16 TSOP	MT5LDT472(A)G (X)	60	UB = 1.000" B = 1.050"	Now	Now
	64MB	SS 8 Meg x 64 3.3V Gold	(8) 8 Meg x 8	MT8LD864AG (X)	50, 60	1.100"	Now	Now
	64MB	DS 8 Meg x 72 3.3V ECC Gold	(36) 4 Meg x 4	MT36LD872(A)G (X)	60	UB = 1.500" B = 1.500"	Now	Now
	64MB	SS 8 Meg x 72 3.3V ECC Gold	(9) 8 Meg x 8	MT9LD872(A)G (X)	50, 60	UB = 1.100" B = 1.250"	Now	Now
	64MB	SS 8 Meg x 72 3.3V ECC Gold	(9) 8 Meg x 8 TSOP	MT9LDT872G (X)	50, 60	1.350"	Now	Now
	128MB	DS 16 Meg x 64 3.3V Gold	(16) 16 Meg x 4	MT16LD1664AG (X)	50, 60	1.250"	Now	Now
	128MB	DS 16 Meg x 72 3.3V ECC Gold	(18) 16 Meg x 4	MT18LD1672(A)G (X)	50, 60	UB = 1.250" B = 1.100"	Now	Now
	128MB	DS 16 Meg x 72 3.3V ECC Gold	(18) 16 Meg x 4 TSOP	MT18LDT1672G (X)	50, 60	2.000"	Now	Now
	256MB	DS 32 Meg x 72 3.3V ECC Gold	(36) 16 Meg x 4	MT36LD3272G (X)	50, 60	2.000"	Now	Now
	256MB	DS 32 Meg x 72 3.3V ECC Gold	(36) 16 Meg x 4 TSOP	MT36LDT3272G (X)	50, 60	2.000"	Now	Now

(A) = 8 CAS, SPD version, unbuffered; no **A** = Buffered version for x72 DIMMs. **UB** = Unbuffered; **B** = Buffered. *Highlighted parts are not recommended for new designs.*



MODULE KEY

DS = Double Sided, **SS** = Single Sided; **M** = Tin Plated, **G** = Gold Plated; **U** = 100-pin DIMM, **UDG** = Double-sided, dual-bank 100-pin DIMM, **H** = Small-Outline DIMM (SODIMM), **(A)** = see footnote references below

SDRAM MODULES

Family	Density	Description	Module Components	Module Part Number	Speed	Die Rev.	PCB (Height)	MHz	Samp.	Prod.	Note*
100-pin DIMM	4MB	SS 1 Meg x 32 3.3V Gold	(2) 1 Meg x 16 TSOP	MT2LSDT132UG	-10E1 -8E1	E = Y72G	1 = 6649 (1")	100 125	Now Now	Now Now	
	8MB	DS 2 Meg x 32 3.3V Gold	(4) 1 Meg x 16 TSOP	MT4LSDT232UDG	-10E1 -8E1	E = Y72G	1 = 6649 (1")	100 125	Now Now	Now Now	
	16MB	SS 4 Meg x 32 3.3V Gold	(2) 4 Meg x 16 TSOP	MT2LSDT432UG	-10C1 -8C1	C = Y84	1 = 6660 (1")	100 125	Now Now	Now Now	
	32MB	DS 8 Meg x 32 3.3V Gold	(4) 4 Meg x 16 TSOP	MT4LSDT832UDG	-10C1 -8C1	C = Y84	1 = 6660 (1")	100 125	Now Now	Now Now	
	64MB	DS 16 Meg x 32 3.3V Gold	(4) 16 Meg x 8 TSOP	MT4LSDT1632UG	-10B1 -8B1	B = Y85B	1 = 6692 (1.15")	100 125	Now Now	Now Now	
	128MB	DS 32 Meg x 32 3.3V Gold	(8) 16 Meg x 8 TSOP	MT8LSDT3232UG	-10B1 -8B1	B = Y85B	1 = 6692 (1.15")	100 125	Now Now	Now Now	
144-pin SODIMM	32MB	DS 4 Meg x 64 3.3V Gold	(4) 4 Meg x 16 TSOP	MT4LSDT464(L)HG	-662C1 -662C2 -10EC3	C = Y84	1 = 6645 (1.15") 2 = 6669 (1")	66 66	Now Now	Now Now	PC100
	64MB	DS 8 Meg x 64 3.3V Gold	(8) 8 Meg x 8 TSOP 4 Meg x 16 TSOP	MT8LSDT864(L)HG MT8LSDT864(L)HG	-662C3 -10EC5	C = Y84	3 = 6678 (1.05") 5 = 0115C (1.25")	66 100	Now Now	Now Now	PC100
	64MB	DS 8 Meg x 64 3.3V Gold	(4) 8 Meg x 16 TSOP	MT4LSDT864(L)HG	-10EB1 -133B1	B = Y85B	1 = 0118B (1")	100 133	Now Now	Now Now	
	128MB	DS 16 Meg x 64 3.3V Gold	(8) 16 Meg x 8 TSOP (8) 8 Meg x 16 TSOP	MT8LSDT1664(L)HG	-662B2 -10EB1	B = Y85B	1 = 0115C (1.25") 2 = 6678 (1.05")	66 100	Now Now	Now Now	PC100
168-pin DIMM	32MB	SS 4 Meg x 64 3.3V Gold	(4) 4 Meg x 16 TSOP	MT4LSDT464AG	-662C1 -662C6 -10EC6 -133C6	C = Y84	1 = 6652 (1") 6 = 0134 (1")	66 100	Now Now	Now Now	
	64MB	SS 8 Meg x 64 3.3V Gold	(8) 8 Meg x 8 TSOP	MT8LSDT864AG	-662C7 -10EC7 -133C7	C = Y84	7 = 0104B (1.375")	66 100	Now Now	Now Now	
	64MB	SS 8 Meg x 64 3.3V Gold	(4) 8 Meg x 16 TSOP	MT4LSDT864AG	-662B1 -10EB1 -133B1	B = Y85B	1 = 0134 (1")	66 100	Now Now	Now Now	
	64MB	SS 8 Meg x 72 3.3V ECC Gold	(9) 8 Meg x 8 TSOP	MT9LSDT872AG	-662C7 -10EC7 -133C7	C = Y84	7 = 0104B (1.375")	66 100	Now Now	Now Now	
	64MB	SS 8 Meg x 72 3.3V ECC Gold	(9) 8 Meg x 8 TSOP	MT9LSDT872G	-10CC3 -10EC3 -133C3	C = Y84	3 = 0144 (1.5")	100 100	Now Now	Now Now	
	128MB	DS 16 Meg x 64 3.3V Gold	(16) 8 Meg x 8 TSOP	MT16LSDT1664AG	-662C7 -10EC7 -133C7	C = Y84	7 = 0104B (1.375")	66 100	Now Now	Now Now	
	128MB	SS 16 Meg x 64 3.3V Gold	(8) 16 Meg x 8 TSOP	MT8LSDT1664AG	-662B1 -10EB1 -133B1	B = Y85D	1 = 0104 (1.375")	66 100	Now Now	Now Now	
	128MB	DS 16 Meg x 72 3.3V ECC Gold	(18) 8 Meg x 8 TSOP	MT18LSDT1672AG	-662C7 -10EC7 -133C7	C = Y84	7 = 0104B (1.375")	66 100	Now Now	Now Now	
	128MB	DS 16 Meg x 72 3.3V ECC Gold	(18) 16 Meg x 4 TSOP	MT18LSDT1672G	-10CC2 -10EC2 -133C2	C = Y84	2 = 0129 (1.7")	100 100	Now Now	Now Now	
	128MB	SS 16 Meg x 72 3.3V Gold	(9) 16 Meg x 8 TSOP	MT9LSDT1672AG	-662B1 -10EB1 -133B1	B = Y85B	1 = 0104 (1.375")	66 100	Now Now	Now Now	
	128MB	SS 16 Meg x 72 3.3V Gold	(9) 16 Meg x 8 TSOP	MT9LSDT1672G	-10EB1 -133B1	B = Y85B	1 = 0144 (1.7")	100 133	Now Now	Now Now	
	256MB	DS 32 Meg x 64 3.3V Gold	(16) 16 Meg x 8 TSOP	MT16LSDT3264AG	-10EB1 -133B1	B = Y85B	1 = 0104B (1.375")	100 133	Now Now	Now Now	
	256MB	DS 32 Meg x 72 3.3V ECC Gold	(18) 16 Meg x 8 TSOP	MT18LSDT3272AG	-10EB1 -133B1	B = Y85B	1 = 0104B (1.375")	100 133	Now Now	Now Now	
	256MB	DS 32 Meg x 72 3.3V ECC Gold	(18) 32 Meg x 4 TSOP	MT18LSDT3272G	-10EB1 -133B1	B = Y85B	1 = 0129 (1.7")	100 133	Now Now	Now Now	
	512MB	DS 64 Meg x 72 3.3V ECC Gold	(36) 32 Meg x 4 FBGA	MT36LSDF6472G	-10EB1 -133B2	B = Y85B	1 = 0123 (1.6") 2 = TBD (1.6")	100 133	Now Now	Now Now	11x13 pkg.
	1GB	DS 128 Meg x 72 3.3V Gold	(36) 32 Meg x 4 TSOP	MT36LSDT12872G	-10EA1 -133A1	A = Y86	1 = TBD (1.7")	100 133	5/00 5/00	7/00 7/00	

(A) = SPD version, nonregistered; no A = registered version for x72 DIMMs. 144- and 168-pin DIMMs (66 MHz/100 MHz) adhere to Intel®'s 4-clock SDRAM module specs (66 MHz uses -10 components, 100 MHz uses -8, 133 MHz uses -75). For 100-pin DIMMs, 100 MHz uses -10 components; adheres to JEDEC standard.

DDR SDRAM MODULES

Family	Density	Description	Module Components	Module Part Number	Speed	Die Rev.	PCB (Height)	MHz	Sample	Production
184-pin DIMM	64MB	SS 8 Meg x 64 2.5V Gold	(8) 8 Meg x 8 TSOP	MT8VDDT864AG	-202A1	A = T84	1 = TBD (1.25")	200	Now	4/00
					-265A1			266	Now	4/00
					-262A1			266	Now	4/00
	64MB	SS 8 Meg x 72 2.5V Gold	(9) 8 Meg x 8 TSOP	MT9VDDT872AG	-202A1	A = T84	1 = TBD (1.25")	200	Now	4/00
					-265A1			266	Now	4/00
					-262A1			266	Now	4/00
	64MB	SS 8 Meg x 72 2.5V Gold	(9) 8 Meg x 8 TSOP	MT9VDDT872G	-202A1	A = T84	1 = TBD (1.80")	200	Now	4/00
					-265A1			266	Now	4/00
					-262A1			266	Now	4/00
	128MB	DS 16 Meg x 64 2.5V Gold	(16) 8 Meg x 8 TSOP	MT16VDDT1664AG	-202A1	A = T84	1 = TBD (1.25")	200	Now	4/00
					-265A1			266	Now	4/00
					-262A1			266	Now	4/00
	128MB	DS 16 Meg x 72 2.5V Gold	(18) 8 Meg x 8 TSOP	MT18VDDT1672AG	-202A1	A = T84	1 = TBD (1.25")	200	Now	4/00
					-265A1			266	Now	4/00
					-262A1			266	Now	4/00
	128MB	DS 16 Meg x 72 2.5V Gold	(18) 8 Meg x 8 TSOP	MT18VDDT1672DG	-202A1	A = T84	1 = TBD (1.80")	200	Now	4/00
-265A1					266			Now	4/00	
-262A1					266			Now	4/00	
128MB	DS 16 Meg x 72 2.5V Gold	(18) 16 Meg x 4 TSOP	MT18VDDT1672G	-202A1	A = T84	1 = TBD (1.80")	200	Now	4/00	
				-265A1			266	Now	4/00	
				-262A1			266	Now	4/00	
256MB	DS 32 Meg x 64 2.5V Gold	(16) 16 Meg x 8 TSOP	MT16VDDT3264AG	-202A1	A = T85	1 = TBD	200	4/00	3000	
				-265A1			266	4/00	3000	
				-262A1			266	TBD	TBD	
256MB	DS 32 Meg x 72 2.5V Gold	(18) 16 Meg x 8 TSOP	MT18VDDT3272AG	-202A1	A = T85	1 = TBD	200	4/00	3000	
				-265A1			266	4/00	3000	
				-262A1			266	TBD	TBD	
256MB	DS 32 Meg x 72 2.5V Gold	(18) 16 Meg x 8 TSOP	MT18VDDT3272DG	-202A1	A = T85	1 = TBD	200	4/00	3000	
				-265A1			266	4/00	3000	
				-262A1			266	TBD	TBD	
256MB	DS 32 Meg x 72 2.5V Gold	(18) 32 Meg x 4 TSOP	MT18VDDT3272G	-202A1	A = T85	1 = TBD	200	4/00	3000	
				-265A1			266	4/00	3000	
				-262A1			266	TBD	TBD	
512MB	DS 64 Meg x 72 2.5V Gold	(36) 32 Meg x 4 TSOP	MT36VDDT6472G	-202A1	A = T85	1 = TBD	200	TBD	TBD	
				-265A1			266	TBD	TBD	
				-262A1			266	TBD	TBD	

RIMM™ MODULES

Pins	Density	Description	Module Components	Module Part Number	Speed	Die Rev.	PCB (Height)	MHz	Sample	Prod.		
184-pin	64MB	SS 32 Meg x 16 non-ECC	(4) 8 Meg x 16	MT4VR3216AG	-750A1	A = R85A B = R85C	1 = TBD (1.25")	700	TBD	TBD		
					-850A1			800	TBD	TBD		
					-845A1			800	TBD	TBD		
					-750B1			700	TBD	TBD		
					-745B1			700	TBD	TBD		
					-850B1			800	TBD	TBD		
					-845B1			800	TBD	TBD		
					-840B1			800	TBD	TBD		
					-750A1			A = R85A	1 = TBD (1.25")	700	TBD	TBD
					-745A1					700	TBD	TBD
					-850A1					800	TBD	TBD
					-845A1					800	TBD	TBD
	-840A1	800	TBD	TBD								
	-840A1	800	TBD	TBD								
	96MB	SS 48 Meg x 16 non-ECC	(6) 8 Meg x 16	MT6VR4816AG	-750A1	A = R85A B = R85C	1 = TBD (1.25")	700		TBD	TBD	
					-850A1			800		TBD	TBD	
					-845A1			800		TBD	TBD	
					-750B1			700		TBD	TBD	
					-745B1			700		TBD	TBD	
					-850B1			800		TBD	TBD	
					-845B1			800	TBD	TBD		
					-840B1			800	TBD	TBD		
					-750A1			A = R85A	1 = TBD (1.25")	700	TBD	TBD
					-745A1					700	TBD	TBD
-850A1					800					TBD	TBD	
-845A1					800					TBD	TBD	
-840A1	800	TBD	TBD									
-840A1	800	TBD	TBD									
128MB	SS 64 Meg x 16 non-ECC	(8) 8 Meg x 16	MT8VR6416AG	-750A1	A = R85A B = R85C	1 = TBD (1.25")	700	4/00		3Q00		
				-850A1			800	4/00		3Q00		
				-845A1			800	4/00		3Q00		
				-750B1			700	8/00		4Q00		
				-745B1			700	8/00		4Q00		
				-850B1			800	8/00		4Q00		
				-845B1			800	8/00	4Q00			
				-840B1			800	TBD	TBD			

RIMM™ MODULES (continued)

Pins	Density	Description	Module Components	Module Part Number	Speed	Die Rev.	PCB (Height)	MHz	Sample	Prod.
184-pin	128MB	SS 64 Meg x 18 ECC	(8) 8 Meg x 18	MT8VR6418AG	-750A1	A = R85A	1 = TBD (1.25")	700	4/00	3Q00
					-745A1			700	4/00	3Q00
					-850A1			800	4/00	3Q00
					-845A1			800	4/00	3Q00
					-840A1			800	TBD	TBD
	256MB	SS 128 Meg x 18 non-ECC	(8) 8 Meg x 16 (8) 8 Meg x 16	MT16VR12816AG	-750A1	A = R85A B = R85C	1 = TBD (1.25")	700	6/00	4Q00
					-850A1			800	6/00	4Q00
					-845A1			800	6/00	4Q00
					-750B1			700	8/00	4Q00
					-745B1			700	8/00	4Q00
					-850B1			800	8/00	4Q00
					-845B1			800	8/00	4Q00
					-840B1			800	TBD	TBD
	256MB	SS 128 Meg x 18 ECC	(8) 8 Meg x 18 (8) 8 Meg x 18	MT16VR12818AG	-750A1	A = R85A	1 = TBD (1.25")	700	6/00	4Q00
					-745A1			700	6/00	4Q00
-850A1					800			6/00	4Q00	
-845A1					800			6/00	4Q00	
-840A1					800			TBD	TBD	