

PRODUCT DATA DRAWING

REVISION HISTORY			
REV	DESCRIPTION	DATE	APPROVED
A	DCN 41763	10/15	MAL

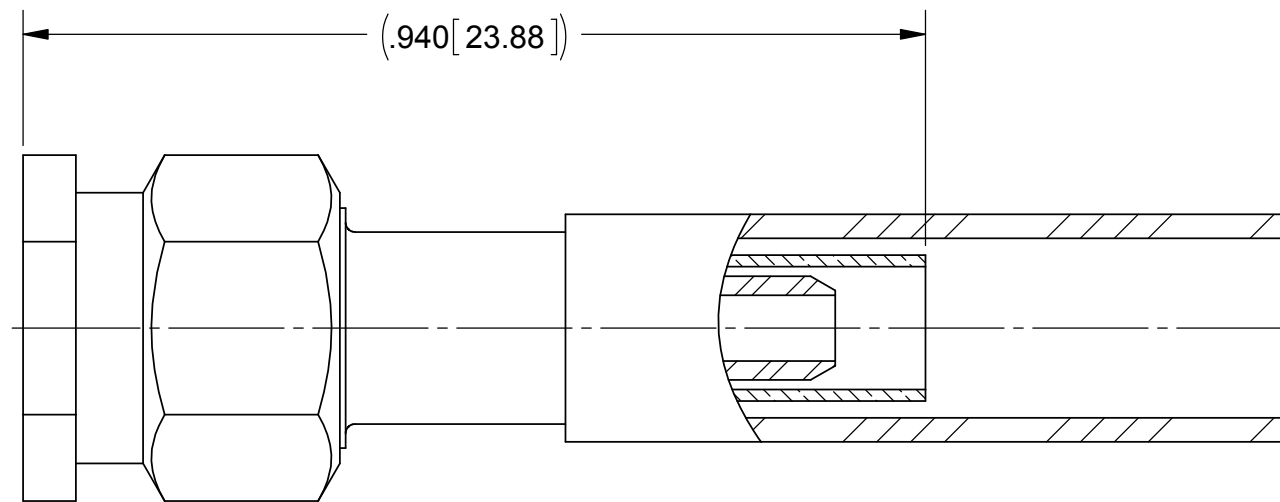
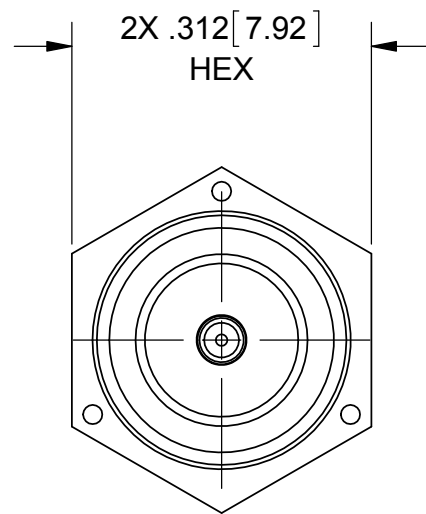
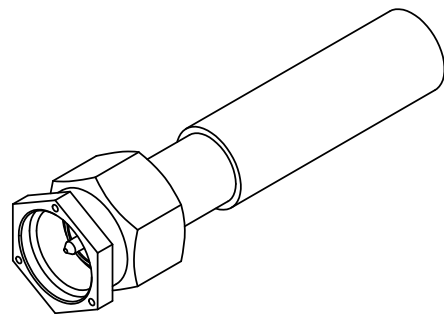

MATERIAL:

- BODY & COUPLING NUT: STAINLESS STEEL PER AMS-5640, ALLOY UNS S30300, TYPE 1
- LOCK RING: BERYLLIUM COPPER PER ASTM B196, ALLOY No. UNS C17300, TD04
- CONTACT & CRIMP RING: BRASS PER ASTM B16, ALLOY UNS No. C36000
- INSULATOR: PTFE PER ASTM D1710, TYPE I, GRADE 1, CLASS B
- GASKET: SILICONE RUBBER PER A-A-59588, CLASS 2B, GRADE 50/60
- TUBING: M23053/4

FINISH:

- BODY & COUPLING NUT: PASSIVATED PER AMS-2700
- CONTACT: GOLD PER ASTM B488, TYPE II, CODE C, CLASS 1.27, OVER NICKEL PER AMS-QQ-N-290, CLASS 1
- CRIMP RING: NICKEL PER AMS-QQ-N-290, CLASS 2

PERFORMANCE:

- IMPEDANCE: 50 OHMS
- FREQ. RANGE: DC TO 12.4 GHz
- VSWR: 1.15 + .02(F):1 DC TO 12.4 GHz
- INSERTION LOSS: .06 X SQRT(F(F IN GHz))

MATERIAL: SEE NOTES	DIMENSIONS ARE IN INCHES TOLERANCES: FRACTIONAL: ±1/64 ANGULAR: X° ±1°0' X'X' ±15'	UNLESS OTHERWISE SPECIFIED 1) ALL DIMENSIONS ARE IN INCHES (MILLIMETERS) 2) ALL DIMENSIONS ARE AFTER PLATING. 3) BREAK CORNERS & EDGES .005 R. MAX. 4) CHAM. 1ST & LAST THREADS. 5) SURFACE ROUGHNESS 63-MIL-STD-10. 6) DIA.'S ON COMMON CENTERS TO BE CONCENTRIC WITHIN .005 T.I.R. 7) REMOVE ALL BURRS	 2400 Centrepark West Drive, Suite 100 West Palm Beach, FL 33409 TITLE: SMA STRAIGHT CRIMP PLUG FOR RG-316 CABLE
FINISH: SEE NOTES	DECIMAL: X ±.030 .XX ±.010 .XXX ±.005	INTERPRET DIMENSIONS AND TOLERANCES PER ASME Y14.5M - 1994	
SURFACE AREA: N/A	THIRD ANGLE PROJECTION	DRAWN: DAL 10/12/15	SIZE: B
PROPRIETARY THE INFORMATION CONTAINED IN THIS DRAWING IS THE SOLE PROPERTY OF SV MICROWAVE, INC. ANY REPRODUCTION IN PART OR AS A WHOLE WITHOUT THE WRITTEN PERMISSION OF SV MICROWAVE, INC IS PROHIBITED.		CHECKED: MAL 10/12/15	DWG. NO. M39012/55-3026
		APPROVED: DGG 02/26/86	SCALE: 5:1 SHEET 1 OF 1