

Cable connector - RC-1RS1N121L0Y - 1603165

Please be informed that the data shown in this PDF Document is generated from our Online Catalog. Please find the complete data in the user's documentation. Our General Terms of Use for Downloads are valid (<http://phoenixcontact.com/download>)



Cable connector, RC, straight, shielded: no, Screw locking, M23, cable diameter range: 9 mm ... 13 mm

The figure shows the 12-pos. product version, with standard DIN cable gland

RoHS

Key Commercial Data

Packing unit	1
GTIN	 4 046356 243902
GTIN	4046356243902
Custom tariff number	85366990

Technical data

Housing data

Housing material	Metal
Type of locking	Screw locking
Degree of protection (when plugged in)	IP65
	IP67
	IP68
Thread type	M23

Cable seal data

Cable diameter	9 mm ... 13 mm
----------------	----------------

Environmental Product Compliance

	Lead 7439-92-1
--	----------------

Cable connector - RC-1RS1N121L0Y - 1603165

Technical data

Environmental Product Compliance

China RoHS	Environmentally Friendly Use Period = 50
	For details about hazardous substances go to tab "Downloads", Category "Manufacturer's declaration"

Drawings

Dimensional drawing

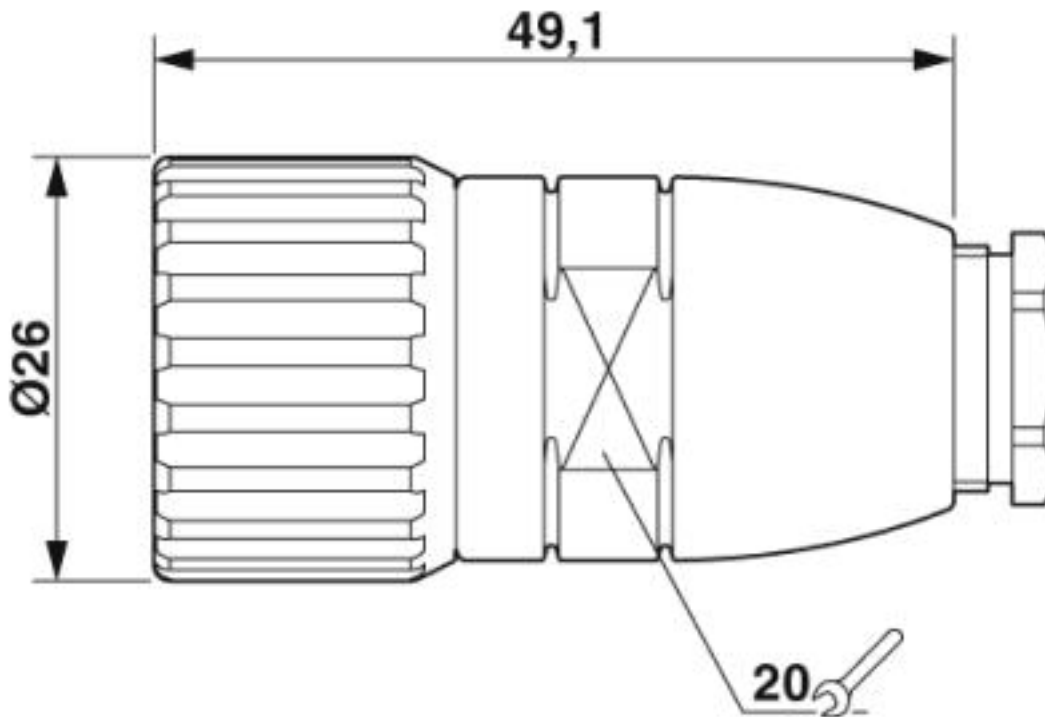

Classifications

eCl@ss

eCl@ss 4.0	272607xx
eCl@ss 4.1	272607xx
eCl@ss 5.0	27260701
eCl@ss 5.1	27260701
eCl@ss 6.0	27260708
eCl@ss 8.0	27440102
eCl@ss 9.0	27440103

Cable connector - RC-1RS1N121L0Y - 1603165

Classifications

ETIM

ETIM 3.0	EC001121
ETIM 4.0	EC001121
ETIM 5.0	EC002635
ETIM 6.0	EC002061

UNSPSC

UNSPSC 13.2	39121413
-------------	----------

Approvals

Approvals

Approvals

EAC

Ex Approvals

Approval details

EAC		B.01742
-----	-------------------------------------------------------------------------------------	---------