

Programmable Timer/Counter

GENERAL DESCRIPTION

The XR-2240 Programmable Timer/Counter is a monolithic controller capable of producing ultra-long time delays without sacrificing accuracy. In most applications, it provides a direct replacement for mechanical or electromechanical timing devices and generates programmable time delays from microseconds up to five days. Two timing circuits can be cascaded to generate time delays up to three years.

As shown in Figure 1, the circuit is comprised of an internal time-base oscillator, a programmable 8-bit counter and a control flip-flop. The time delay is set by an external R-C network and can be programmed to any value from 1 RC to 255 RC.

In stable operation, the circuit can generate 256 separate frequencies or pulse-patterns from a single RC setting and can be synchronized with external clock signals. Both the control inputs and the outputs are compatible with TTL and DTL logic levels.

FEATURES

- Timing from micro-seconds to days
- Programmable delays: 1 RC to 255 RC
- Wide supply range; 4V to 15V
- TTL and DTL compatible outputs
- High accuracy: 0.5%
- External Sync and Modulation Capability
- Excellent Supply Rejection: 0.2 %/N

APPLICATIONS

- Precision Timing
- Frequency Synthesis
- Long Delay Generation
- Pulse Counting/Summing
- Sequential Timing
- A/D Conversion
- Binary Pattern Generation
- Digital Sample and Hold

ABSOLUTE MAXIMUM RATINGS

Supply Voltage	18V
Power Dissipation	
Ceramic Package	750 mW
Derate above + 25°C	6 mw/°C
Operating Temperature XR-2240	-55°C to + 125°C
Storage Temperature	-65°C to + 150°C
Rev-B	

FUNCTIONAL BLOCK DIAGRAM

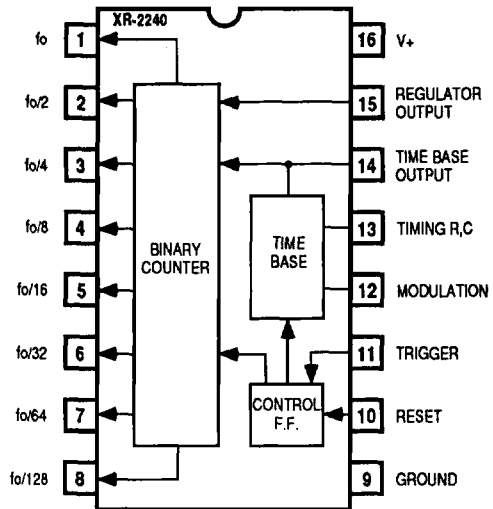

SYSTEM DESCRIPTION

The XR-2240 is a combination timer/counter capable of generating accurate timing intervals ranging from microseconds through several days. The time base works as an astable multivibrator with a period equal to RC. The eight bit counter can divide the time base output by any integer value from 1 to 255. The wide supply voltage range of 4.5 to 15 V, TTL and DTL logic compatibility, and 0.5% accuracy allow wide applicability. The counter may operate independently of the time base. Counter outputs are open collector and may be wire- OR connected.

The circuit is triggered or reset with positive going pulses. By connecting the reset pin (Pin 10) to one of the counter outputs, the time base will halt at timeout. If none of the outputs are connected to the reset, the circuit will continue to operate in the astable mode. Activating the trigger terminal (Pin 11) while the timebase is stopped will set all counter outputs to the low state and start the timebase.

XR-2240

ELECTRICAL PERFORMANCE CHARACTERISTICS - XR-2240

TEST	CONDITIONS	TEMPERATURE	LIMITS		UNIT	GROUP A SUBGROUP
			MIN	MAX		
Supply Current	V+ = 5V	TA = +25°C -55°C ≤ TA ≤ +125°C		6	mA	1
				8	mA	2, 3
Supply Current	V+ = 15V	TA = +25°C -55°C ≤ TA ≤ +125°C		16	mA	1
				20	mA	
Regulator Output	V+ = 5V	TA = +25°C -55°C ≤ TA ≤ +125°C	4.1		V	1
			3.7		V	2, 3
Regulator Output	V+ = 15V	TA = +25°C -55°C ≤ TA ≤ +125°C	6.0	6.6	V	1
			5.2	7.0	V	2, 3
Timing Accuracy	R = 10KΩ, C = 0.1μF	TA = +25°C -55°C ≤ TA ≤ +125°C		2.0	%	9
				6.0	%	10, 11
Supply Drift	8V ≤ V+ ≤ 15V	TA = +25°C -55°C ≤ TA ≤ +125°C		0.2	%/V	9
				0.4	%/V	10, 11
Maximum Frequency	R = 1 KΩ, C = 0.007μF	TA = +25°C -55°C ≤ TA ≤ +125°C	100		KHz	9
			85		KHz	10, 11
Modulation Voltage Level	V+ = 5V	TA = +25°C -55°C ≤ TA ≤ +125°C	3	4	V	1
			3	4	V	2, 3
Trigger Threshold		TA = +25°C -55°C ≤ TA ≤ +125°C		2.0	V	1
				2.3	V	2, 3
Reset Threshold		TA = +25°C -55°C ≤ TA ≤ +125°C		2.0	V	1
				2.3	V	2, 3
Max Toggle Rate		TA = +25°C	0.5		MHz	9
Input Threshold	V+ = 5V	TA = +25°C -55°C ≤ TA ≤ +125°C	1.0		V	1
			0.5		V	2, 3
Output Sink Threshold	VOL ≤ 0.4V VREG = V+ = 5V	TA = +25°C -55°C ≤ TA ≤ +125°C	3		mA	1
			2		mA	2, 3
Output Leakage Current	VOH = 15V	TA = +25°C -55°C ≤ TA ≤ +125°C		8	μA	1
				8	μA	2, 3