

This document, including the design, configuration and mechanical features revealed herein are the sole, confidential and proprietary property of TRU Corporation. Reproduction or use thereof, in whole or part, is prohibited without the prior written consent of TRU Corporation.

REV.	DESCRIPTION	DATE	APPROVED
-	ORIGINAL ISSUE	07/17/07	AM

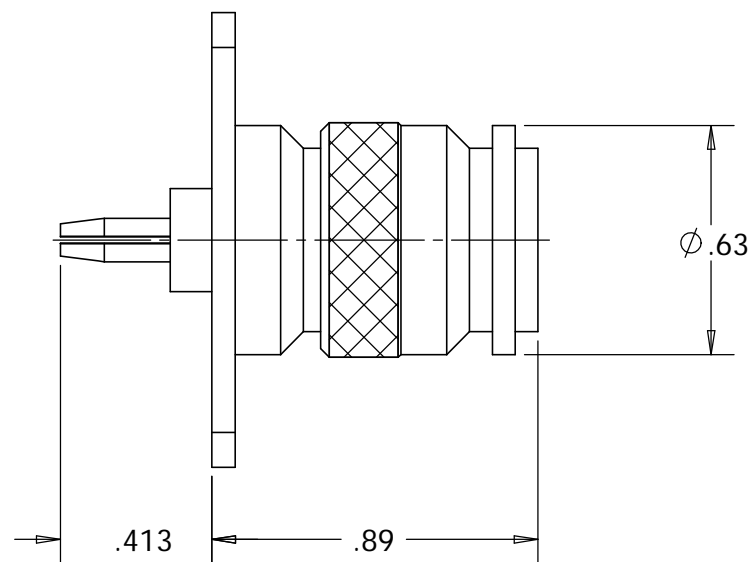
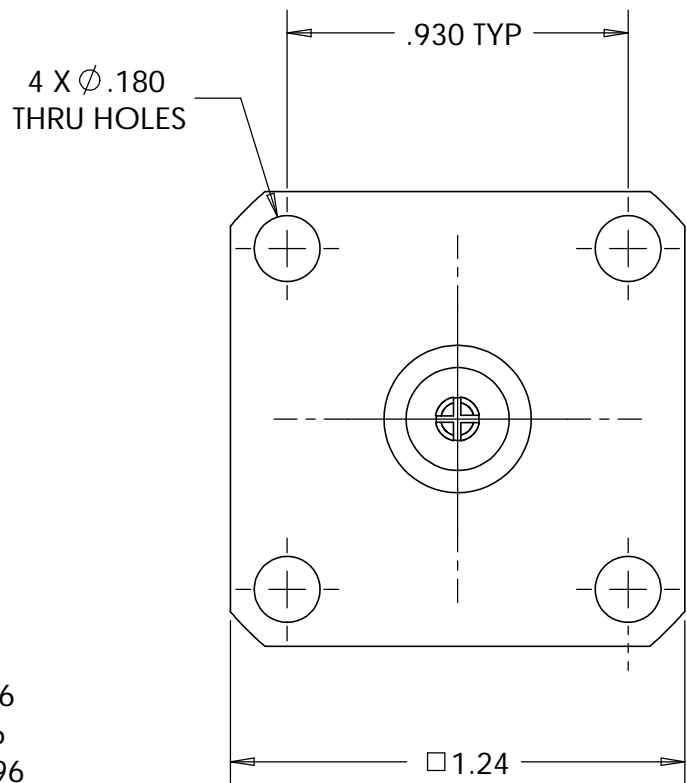
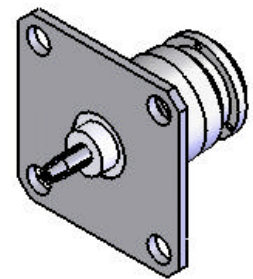

ENGINEERING DATA:

ELECTRICAL:
 IMPEDANCE: 50 OHMS NOMINAL

MECHANICAL:
 INTERFACE: TNC(m) PER MIL-STD-348 FIG.313.1
 QC(m) PER TRU SPEC

MATERIAL:
 GASKET: SILICONE RUBBER PER A-A-59588A, CLASS 2A, GRADE 50
 INSULATOR: TEFLON PER ASTM-D1710, I1A
 TNC(m) CONTACT: BERYLLIUM COPPER C17300, TD04 PER ASTM-B196
 QC(m) CONTACT: BERYLLIUM COPPER C17300, TD04 PER ASTM-B196
 CONTACT FINGERS: BERYLLIUM COPPER C17300, TD04 PER ASTM-B196
 OTHER METAL PARTS: BRASS C36000, H02 PER ASTM-B16

FINISH:
 CONTACTS: SILVER PLATED
 OTHER METAL PARTS: NICKEL PLATED

- NOTES:**
- UNLESS OTHERWISE SPECIFIED; ALL DIMENSIONS ARE REFERENCE ONLY.
 - PRODUCT COMPLIES WITH ROHS DIRECTIVE 2002/95/EC.

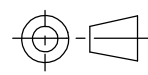
MATERIAL	DO NOT SCALE DRAWING	DRAWN AM	DATE 07/17/07	 TRU CORPORATION 245 LYNNFIELD STREET, PEABODY, MA 01960 The Custom Interconnect Leader™
	UNLESS OTHERWISE SPECIFIED: DIMENSIONS ARE IN INCHES	ENG APPR. AM	DATE 07/17/07	
COMMENTS:	TOLERANCES: FRACTIONS: ±1/64 .XX : ±.01 .XXX: ±.005 ANGLES: ±1/2° MACHINED SURFACES: 63/√	MFG APPR.	DATE	TITLE: CONNECTOR, COAXIAL, RF TNC(m) to QC(m) ADAPTER
		OTHER APPR. RMK	DATE 07/17/07	
surface area: sq inch	weight: 0.07 lbs	THIRD ANGLE PROJECTION		SIZE B DWG. NO. TRU-15030 REV -
				CAGE CODE: 92180 SCALE: 2:1 SHEET 1 OF 1