

GP2W1010YP0F

IrDA Compliant Transceiver Module
9.6 kb/s to 4 Mb/s (FIR)
Low Profile
Low Consumption Current



■ Description

The **GP2W1010YP0F** is an infrared transceiver module for IrDA ver. 1.4 (FIR).

The transceiver consists of a pin-photo diode, infrared emitter and control IC in a single package.

■ Features

1. Compliant with the IrDA 1.4 (FIR)
Transmission speed : 9.6 kb/s to 4 Mb/s
Transmission distance : 70 cm
2. Small package
L 7.9 × W 2.85 × H 2.15 mm
3. Peak emission wavelength : 870 nm
4. Side view type
5. Soldering reflow type
6. Shield type
7. Low consumption current due to shutdown function
(Consumption current at shutdown mode : Max. 1.0 μ A)
8. Operates from 2.7 to 3.3 V
9. With LP/HP mode switching function
10. With V_{IO} terminal

■ Agency approvals/Compliance

1. Compliant with IEC60825-1 class 1 eye safety standard
2. Compliant with RoHS directive (2002/95/EC)
3. **Content status of six substances specified in “Management Methods for Control of Pollution Caused by Electronic Information Products Regulation” (popular name : *China RoHS*) (Chinese : 电子信息产品污染控制管理办法)**
; refer to page 14
4. Lead (Pb) free device

■ Applications

1. Mobile equipment
(Cellular phone, Pager, Smart phone, PDAs, Portable printer, etc.)
2. Digital imaging equipment
(Digital camera, Photo imaging printer)
3. POS equipment
4. Personal computers
5. Personal information tools

Notice The content of data sheet is subject to change without prior notice.

In the absence of confirmation by device specification sheets, SHARP takes no responsibility for any defects that may occur in equipment using any SHARP devices shown in catalogs, data books, etc. Contact SHARP in order to obtain the latest device specification sheets before using any SHARP device.

Sheet No.: E3-A00701EN

Date Mar.01.2007

©SHARP Corporation

Block diagram

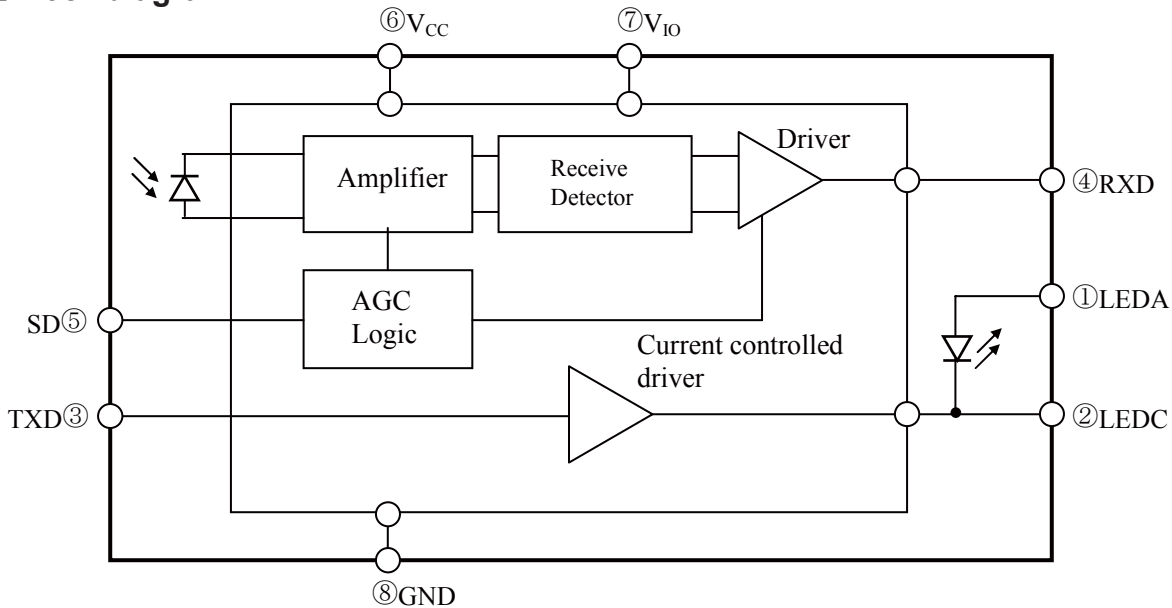

Outline Dimensions

(Unit : mm)

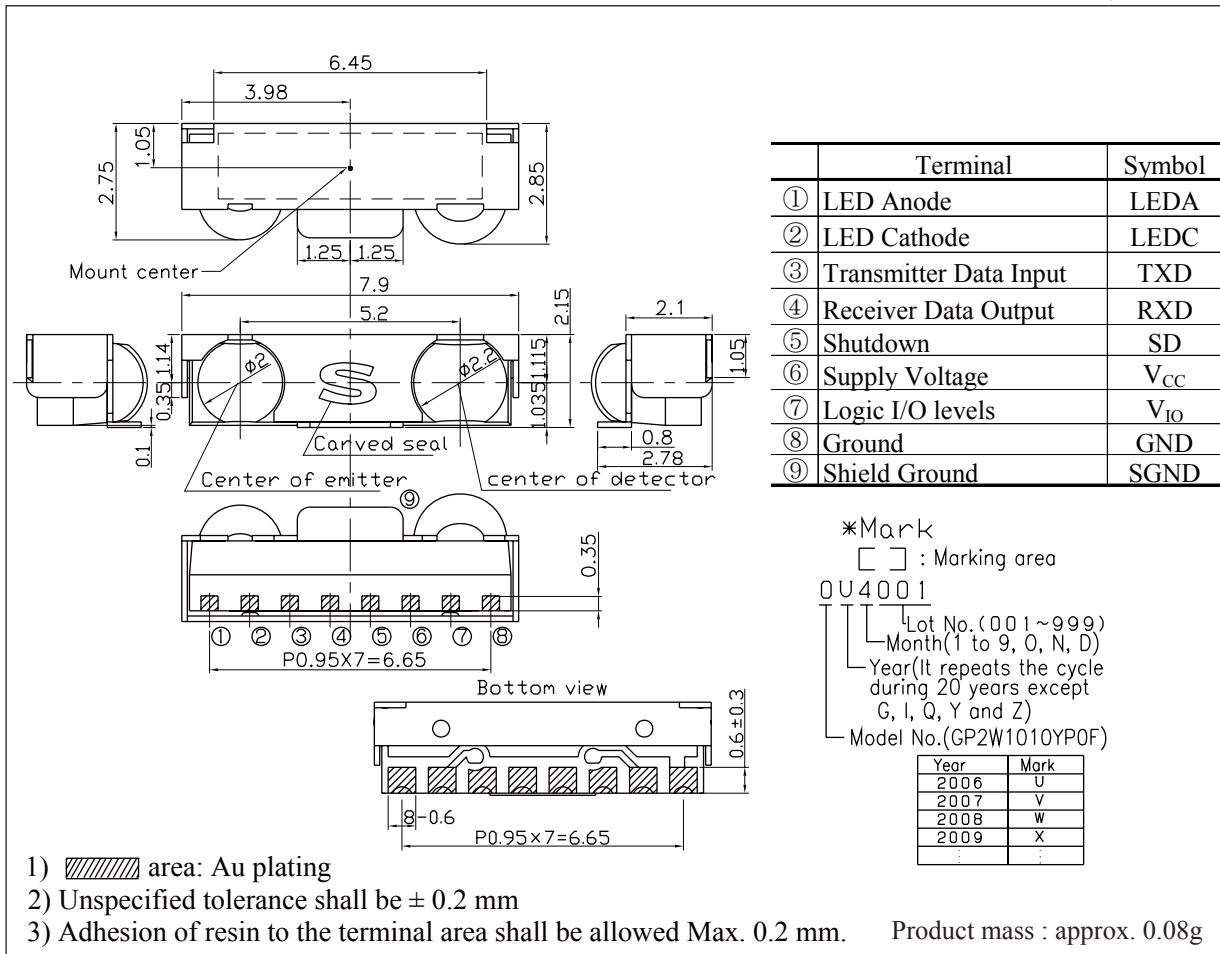

■ Absolute Maximum Ratings (T_a=25°C)

Parameter	Symbol	Rating	Unit
Supply voltage	V _{CC}	-0.3 to 6.0	V
LED Supply voltage	V _{LED}	-0.3 to 7.0	V
Transmission Data Input	TXD	-0.3 to V _{CC} +0.3	V
Shut down	SD	-0.3 to V _{CC} +0.3	V
Logic I/O levels	V _{IO}	-0.3 to V _{CC} +0.3	V
*1 Peak forward current	I _{FM}	600	mA
Operating temperature	T _{opr}	-25 to +85	°C
Storage temperature	T _{stg}	-25 to +85	°C
*2 Soldering temperature	T _{sol}	260	°C

*1 Pulse operation (FIR 4 Mb/s)

*2 Soldering reflow time : 10 seconds

■ Electro-optical Characteristics

($T_{opt}=25 \pm 5^{\circ}\text{C}$, $V_{CC}=3.0\text{V}$ Unless otherwise specified)

Parameter		Symbol	Rating	MIN.	TYP.	MAX.	Unit
Current consumption at no input signal	SIR mode	I_{CC-SIR}	No input signal, $V_{ILSD}=0\text{V}$	—	0.45	0.6	mA
	MIR/FIR mode	I_{CC-FIR}	Output terminal OPEN	—	1.2	1.55	mA
Current consumption at receiving	SIR mode	$I_{CC-RSIR}$	$V_{ILSD}=0\text{V}$	—	0.65	—	mA
	MIR/FIR mode	$I_{CC-RFIR}$	Output terminal OPEN	—	1.3	—	mA
Current consumption at Transmitting	All mode	I_{CC-T}	$V_{IHTXD}=\text{High}$, $V_{ILSD}=0\text{V}$	—	27	55	mA
Current consumption at Shutdown mode		I_{CC-S}	No input signal, $V_{IHSD}=V_{CC}-1.2\text{V}$ Output terminal OPEN	—	0.01	1.0	μA
Receiver	High level output voltage	V_{OH}	$I_{OH}=0.3\text{mA}^{*3}$	$V_{IO}-0.5$	$V_{IO}-0.3$	$V_{IO}+0.3$	V
	Low level output voltage	V_{OL}	$I_{OL}=1\text{mA}^{*3}$	—	—	0.6	V
	Rise time	t_r	BR=4Mb/s, $C_L=15\text{pF}$, $T_a=25^{\circ}\text{C}^{*5}$	—	—	50	ns
	Fall time	t_f		—	—	50	ns
	Low level pulse width	t_{w1}	$t_{w1}, E_{e1}; \text{BR}=9.6\text{kb/s}$, $\phi \leq 15^{\circ}$ $t_{w2}, E_{e1}; \text{BR}=115.2\text{kb/s}$, $\phi \leq 15^{\circ}$ $t_{w3}, E_{e2}; \text{BR}=4\text{Mb/s}(\text{single})$, $\phi \leq 15^{\circ}$ $t_{w4}, E_{e2}; \text{BR}=4\text{Mb/s}(\text{double})$, $\phi \leq 15^{\circ}$ $T_a=25^{\circ}\text{C}$	1	—	24	μs
		t_{w2}		1	—	4	μs
		t_{w3}		67	—	195	ns
		t_{w4}		190	—	320	ns
	Maximum reception distance	L		70	—	—	cm
	Input irradiance	E_{e1}	Except for pulse during a half of preamble	—	—	8.16	$\mu\text{W}/\text{cm}^2$
		E_{e2}		—	—	20.4	$\mu\text{W}/\text{cm}^2$
	Overload irradiance	E_{e3}		500	—	—	mW/cm^2
	Receiver Latency	t_l		—	—	500	μs
	Receiver wakeup time	t_{sdw}	No input signal	—	—	1	ms
	SD input current	I_{isd}	$V_{IHSD}=V_{CC}$, $V_{ILSD}=\text{GND}$	-0.1	0	+0.1	μA
SD terminal Input voltage Logic High	V_{IHSD}	Shutdown mode	$V_{CC}-1.2$	—	V_{CC}	V	
SD terminal Input voltage Logic Low	V_{ILSD}	Normal mode	—	—	0.5	V	
Jitter	t_j	BR=4Mb/s, $T_a=25^{\circ}\text{C}$	—	30	60	ns	
Transmitter	Radiant intensity	I_E	$V_{LED}=5\text{V}$, $R_{LED}=4.7\Omega$ $\phi \leq 15^{\circ}$, $T_a=25^{\circ}\text{C}^{*4}$	50	—	350	mW/sr
	LED peak current	I_{LED}	$V_{LED}=5\text{V}$, $R_{LED}=4.7\Omega$, $T_a=25^{\circ}\text{C}^{*4}$	—	450	550	mA
	Rise time	t_r	BR=4Mb/s, $V_{LED}=5\text{V}$, $T_a=25^{\circ}\text{C}^{*4}$	—	—	40	ns
	Fall time	t_f		—	—	40	ns
	Peak emission wave length	λ_p	$T_a=25^{\circ}\text{C}$	850	870	890	nm
	TXD high level input voltage	V_{IHTXD}	LED(ON), $1.5 \leq V_{IO} \leq 1.8\text{V}$	1.4	—	V_{CC}	V
			LED(ON), $1.8 < V_{IO} \leq V_{CC}$	1.6	—	V_{CC}	V
	TXD low level input voltage	V_{ILTxD}	LED(OFF)	—	—	0.6	V
	TXD high level input current	I_{IHTXD}	$T_a=25^{\circ}\text{C}$	—	—	20	μA
	TXD low level input current	I_{ILTxD}	$T_a=25^{\circ}\text{C}$	—	—	8	μA
Maximum optical pulse width	t_{OPWM}	TXD pin stuck high	30	—	300	μs	

*3 Refer to Fig. 2, 3

*4 Refer to Fig. 4,5,6

Recommended Operating Conditions

($T_a=25^{\circ}\text{C}$)

Parameter	Symbol	Conditions	Rating	Unit
Supply voltage	V_{CC}		2.7 to 3.3	V
LED Supply voltage	V_{LED}	$R_{LED}=4.7\Omega$	2.7 to 5.5	V
Operating temperature	T_{opr}	*5	-25 to +85	$^{\circ}\text{C}$
Data rate	BR		9.6k to 4M	b/s
Logic I/O levels	V_{IO}		15 to V_{CC}	V

*5 When you make Duty 25 % of signal emit light continuously,
please use continuation luminescence time in less than 10 seconds.

Truth Table

MODE	SD	SW1	SW2	TXD	LED	Receiver	TR1	TR2	RXD
Shutdown	H	On	Off	L	Off	Don't Care	Off	Off	H(Pull-up)
Transmitter	L	Off	On	H	On	Don't Care	Off	On	L(echo)
Receiver	L	Off	On	L	Off	IrDA Signal	Off	On	L
	L	Off	On	L	Off	No Signal	On	Off	H

H:high, L:Low

*RXD equivalent circuit

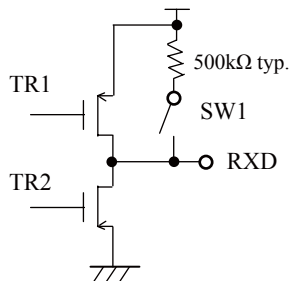

*TXD equivalent circuit

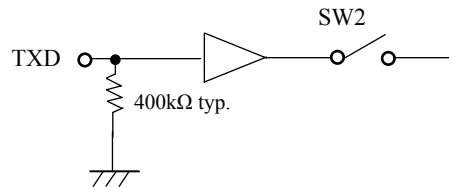
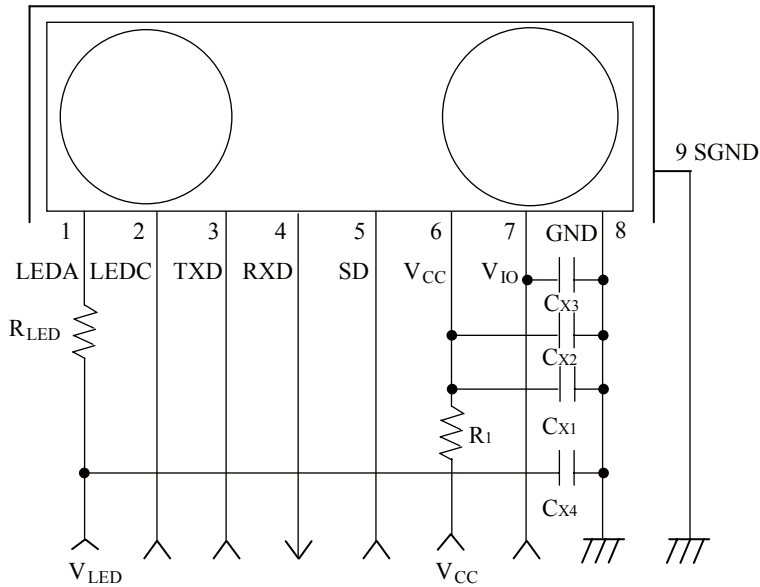

Fig.1 Recommended External Circuit



Components	Recommended values	
C _{X1}	4.7μF(Ceramic)(Note1)	
C _{X2}	0.47μF(Ceramic)(Note1)	
C _{X3}	0.47μF(Ceramic)(Note1)	
C _{X4}	10μF(Ceramic)	
R ₁ (1/16W)	4.7Ω	
R _{LED}	1/2W	4.7Ω(V _{LED} =5V)
	1/10W	0.9Ω(V _{LED} =3.3V)

(Note1) Components choose the most suitable C_{X1}, C_{X2}, C_{X3} according to the noise level and noise frequency of power supply.

Fig.2 Output Waveform Specification(Receiver side)

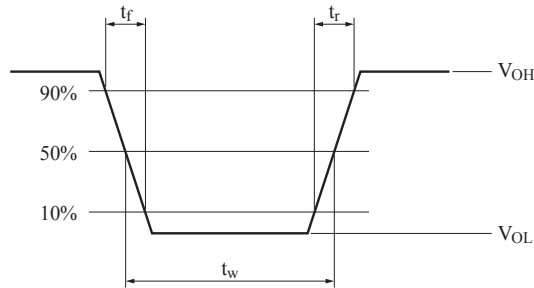
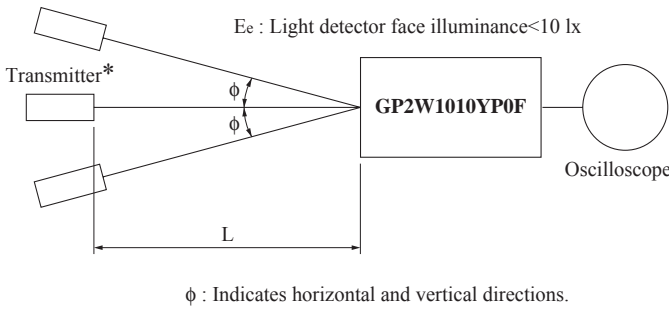

Fig.3 Standard Optical System(Receiver side)



Data rate	T ₁	T ₂	T ₂ /T ₁	Radiant intensity
9.6kb/s	104μs	19.5μs	3/16	40mW/sr
115.2kb/s	8.68μs	1.63μs	3/16	40mW/sr
1.152Mb/s	868ns	217ns	1/4	100mW/sr
4Mb/s	500ns	125ns	1/4	100mW/sr

φ : Indicates horizontal and vertical directions.

* Transmitter shall use the standard transmitter (λ_p = 870 nm TYP.) which is adjusted the radiation intensity at 40 mW/sr (at 9.6 to 115.2 kb/s), 100 mW/sr (at 4 Mb/s).

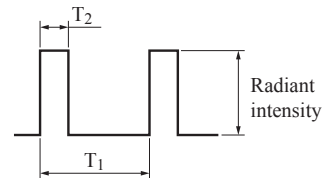

Fig.4 Output Waveform Specification(Transmitter side)

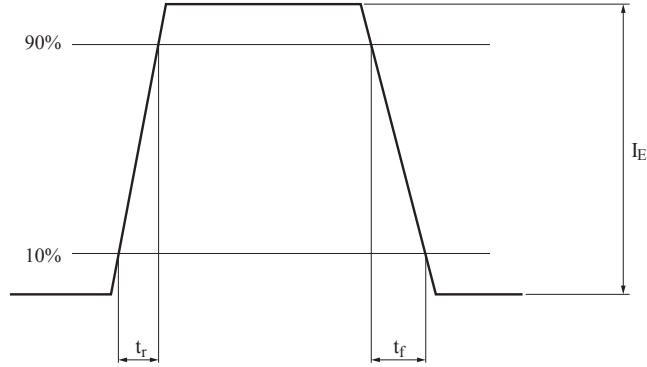

Fig.5 Standard Optical System(Transmitter side)

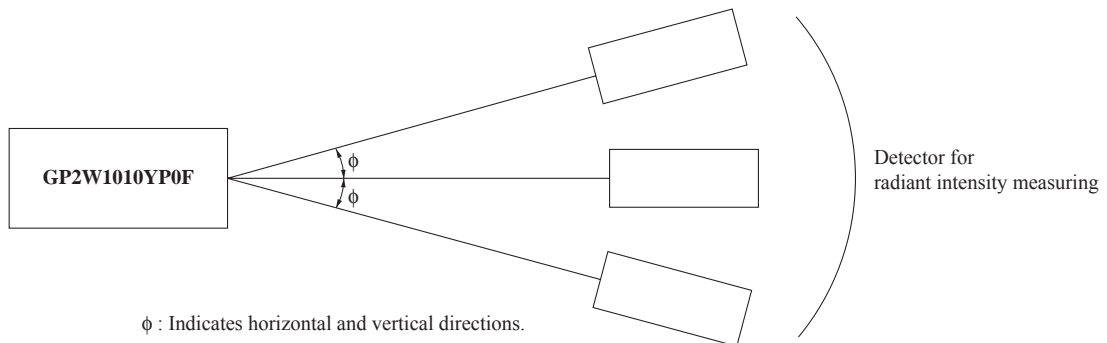

Fig.6 Recommended Circuit of Transmitter side

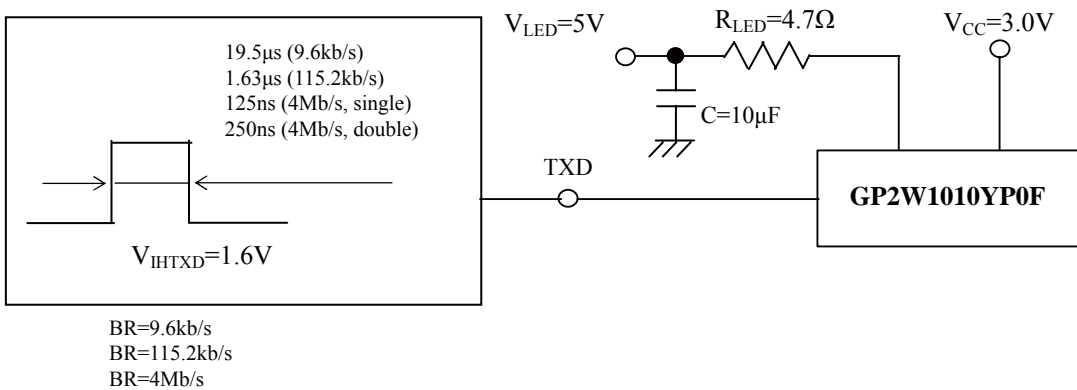
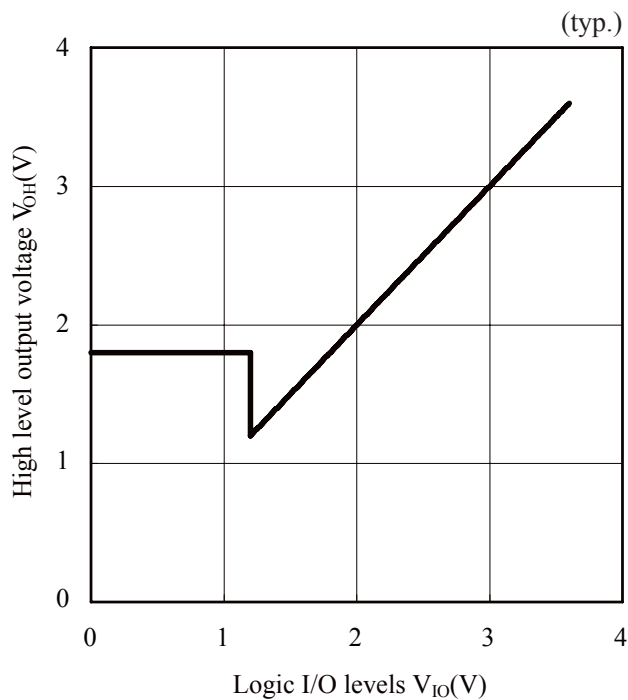

Fig.7 High level output voltage(V_{OH}) vs Logic I/O levels(V_{IO})

Notes

- (1) When the system (program) is designed, the Turn Around Time shall be secured by considering 500 μ s or more that is specified to IrDA.
Then, this Turn Around Time means the time when this device does not temporarily detect the signal light, since the transmitted light from the transceiver reaches the detector side of the transceiver.
- (2) As it is necessary 1 ms or more (at $T_a = 25^\circ\text{C}$, no input signal) to return from shut-down mode to ready-operation mode, please consider this point at the system (program) designing.
Also, please confirm thoroughly the operation in actual application.
- (3) When there is much external disturbing light source is located near this transceiver and the detector face receive much external disturbing light, there is case that the pulse other than signal output is generated as noise on output terminal of this transceiver. Please consider the lay-out and structure to reduce disturbing light on the detector face.
- (4) In case that this sensor is adopted in IR communication system, please use it according to the signal method which is specified by [Serial Infrared Physical Layer Link Specification Version 1.4] published by Infrared Data Association. False operation may happen if the different signal method is used.
- (5) In circuit designing, make allowance for the degradation of light emitting diode output that results from long continuous operation. (50 % degradation/5 years)

■ Soldering Method

1. In case of solder reflow

Please carry out only two times soldering at the temperature and the time within the temperature profile as shown in the figure below. Reflow interval shall be within 3 days under conditions, 10 to 30°C, 70%RH or less.

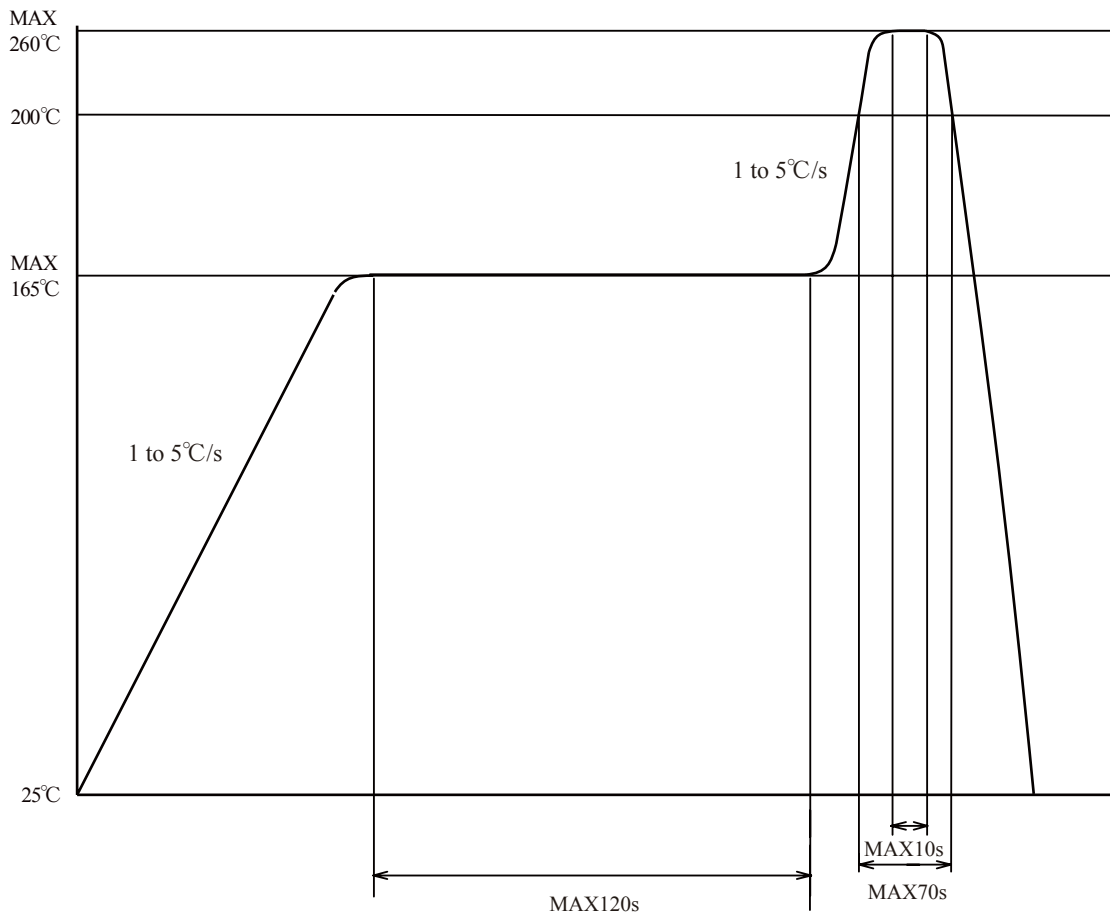

2. Other precautions

An infrared lamp used to heat up for soldering may cause a localized temperature rise in the resin. So keep the package temperature within that specified in Item 1. Also avoid immersing the resin part in the solder. Even if within the temperature profile above, there is the possibility that the gold wire in package is broken in case that the deformation of PCB gives the affection to lead pins. Please use after confirming the conditions fully by actual solder reflow machine.

3. Soldering

- Soldering iron shall be less than 25W, and temperature of point of soldering iron shall use at 300°C or less.
- Soldering time shall be within 5s.
- Soldered product shall treat at normal temperature.

■ Package specification

- Tape and Reel package
- 2000pcs/reel

Carrier tape structure and Dimensions

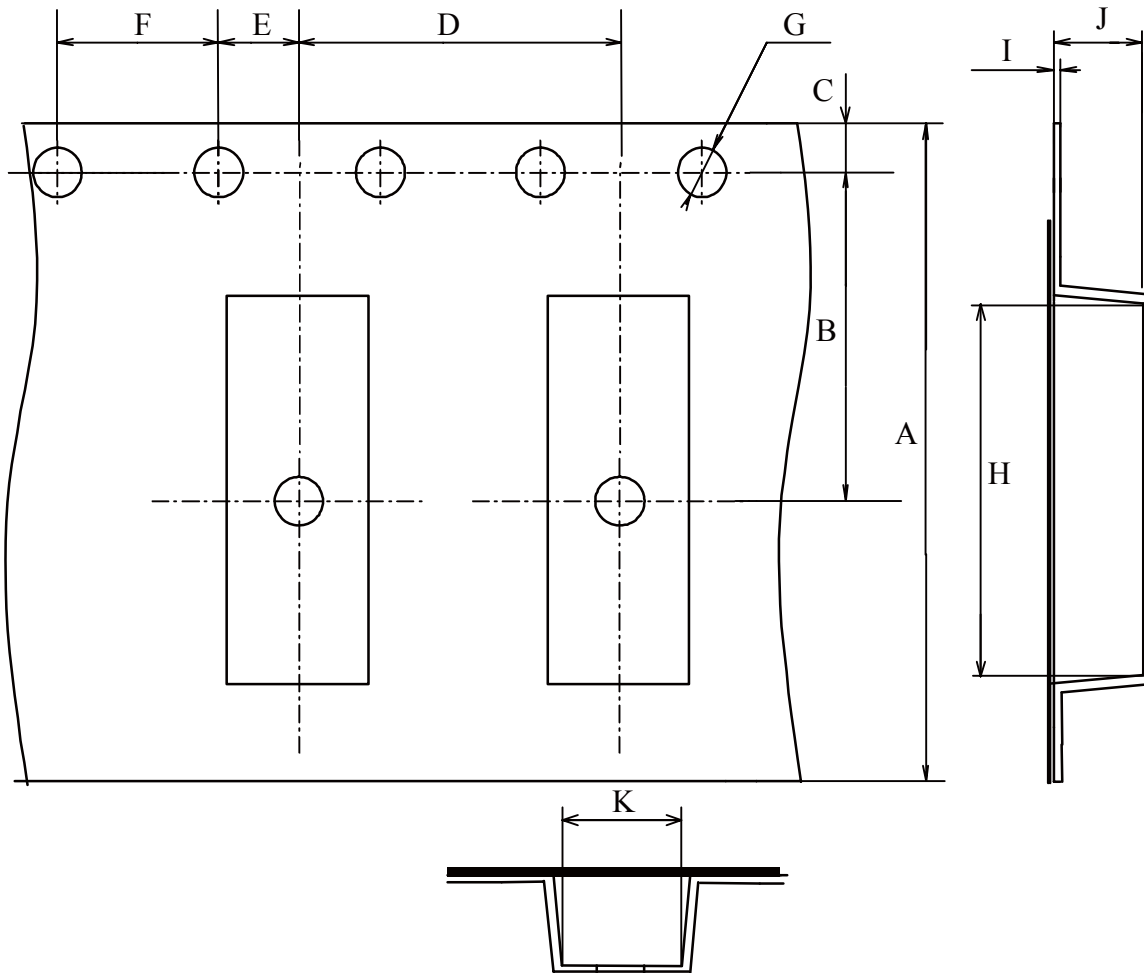

Dimension List

(Unit : mm)

A	B	C	D	E	F
16.0±0.3	7.5±0.1	1.75±0.1	8.0±0.1	2.0±0.1	4.0±0.1
G	H	I	J	K	
φ 1.5 ^{+0.1} _{-0.0}	8.25±0.1	0.32±0.05	2.5±0.1	3.15±0.1	

Reel structure and Dimensions

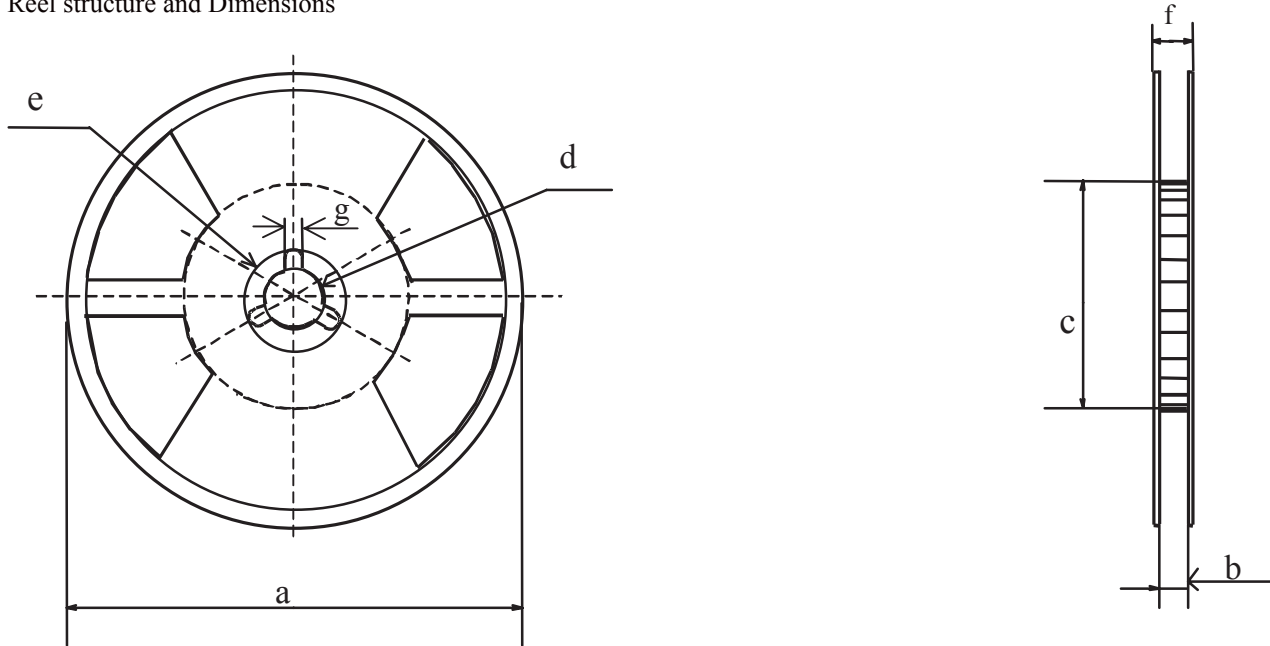

Dimension List (Unit : mm)

a	b	c	d
$\phi 330 \pm 2$	17.5 ± 1.0	$\phi 100 \pm 1$	$\phi 13 \pm 0.2$
e	f	g	
$\phi 21 \pm 0.8$	22.5 ± 1.0	2 ± 0.5	

Direction of product insertion

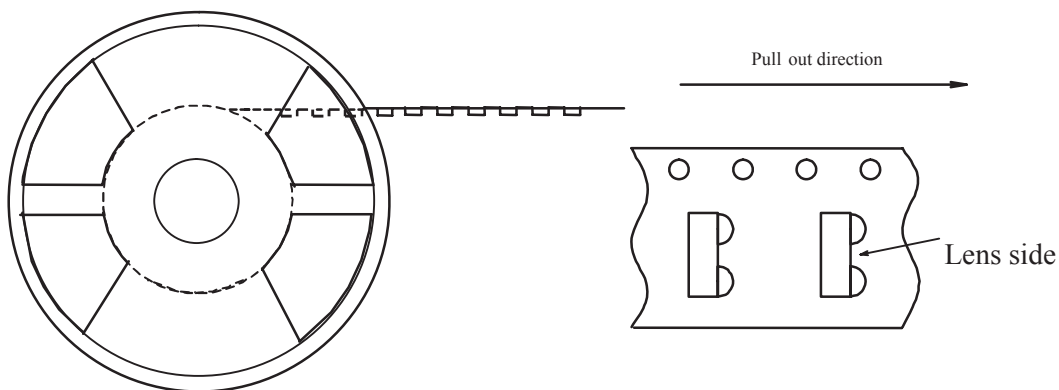

● **Cleaning Instructions**

Solvent cleaning :

Solvent temperature 45°C or less, Immersion for 3 min or less

Ultrasonic cleaning :

The effect to device by ultrasonic cleaning differs by cleaning bath size, ultrasonic power output, cleaning time, PCB size or device mounting condition etc.

Please test it in actual using condition and confirm that doesn't occur any defect before starting the ultrasonic cleaning. The cleaning shall be carried out with solvent below.

Recommended Solvent materials :

Ethyl alcohol, Methyl alcohol, Isopropyl alcohol

● **Presence of ODC etc.**

This product shall not contain the following materials.

And they are not used in the production process for this product.

Regulation substances : CFCs, Halon, Carbon tetrachloride, 1.1.1-Trichloroethane (Methylchloroform)

Specific brominated flame retardants such as the PBB and PBDE are not used in this product at all.

• **The RoHS directive (2002/95/EC)**

This product complies with the RoHS directive (2002/95/EC).

Object substances: lead, cadmium, hexavalent chromium, polybrominated biphenyls (PBB) and polybrominated diphenyl ethers (PBDE)

• **Content of six substances specified in “ Management Methods for Control of Pollution Caused by Electronic Information Products Regulation ” (Chinese : 电子信息产品污染控制管理办法)**

Category	Toxic and hazardous substances					
	Lead (Pb)	Mercury (Hg)	Cadmium (Cd)	Hexavalent chromium (Cr ⁶⁺)	Polybrominated biphenyls (PBB)	Polybrominated diphenyl ethers (PBDE)
Infrared data communication device	✓	✓	✓	✓	✓	✓

✓ : indicates that the content of the toxic and hazardous substance in all the homogeneous materials of the part is below the concentration limit requirement as described in SJ/T 11363-2006 standard.

■ Important Notices

· The circuit application examples in this publication are provided to explain representative applications of SHARP devices and are not intended to guarantee any circuit design or license any intellectual property rights. SHARP takes no responsibility for any problems related to any intellectual property right of a third party resulting from the use of SHARP's devices.

· Contact SHARP in order to obtain the latest device specification sheets before using any SHARP device. SHARP reserves the right to make changes in the specifications, characteristics, data, materials, structure, and other contents described herein at any time without notice in order to improve design or reliability. Manufacturing locations are also subject to change without notice.

· Observe the following points when using any devices in this publication. SHARP takes no responsibility for damage caused by improper use of the devices which does not meet the conditions and absolute maximum ratings to be used specified in the relevant specification sheet nor meet the following conditions:

(i) The devices in this publication are designed for use in general electronic equipment designs such as:

- Personal computers
- Office automation equipment
- Telecommunication equipment [terminal]
- Test and measurement equipment
- Industrial control
- Audio visual equipment
- Consumer electronics

(ii) Measures such as fail-safe function and redundant design should be taken to ensure reliability and safety when SHARP devices are used for or in connection

with equipment that requires higher reliability such as:

- Transportation control and safety equipment (i.e., aircraft, trains, automobiles, etc.)
- Traffic signals
- Gas leakage sensor breakers
- Alarm equipment
- Various safety devices, etc.

(iii) SHARP devices shall not be used for or in connection with equipment that requires an extremely high level of reliability and safety such as:

- Space applications
- Telecommunication equipment [trunk lines]
- Nuclear power control equipment
- Medical and other life support equipment (e.g., scuba).

· If the SHARP devices listed in this publication fall within the scope of strategic products described in the Foreign Exchange and Foreign Trade Law of Japan, it is necessary to obtain approval to export such SHARP devices.

· This publication is the proprietary product of SHARP and is copyrighted, with all rights reserved. Under the copyright laws, no part of this publication may be reproduced or transmitted in any form or by any means, electronic or mechanical, for any purpose, in whole or in part, without the express written permission of SHARP. Express written permission is also required before any use of this publication may be made by a third party.

· Contact and consult with a SHARP representative if there are any questions about the contents of this publication.