



NATIONAL HYBRID, INC.

2200 Smithtown Avenue, Ronkonkoma, NY 11779
(516) 981-2400 FAX 516-981-8888

Mil-Std-1553/1760 Products NHI-1579 Ceramic Package Series +5V Monolithic Dual Transceivers

Features:

- Compliant to Mil-Std-1553A & B, Mil-Std-1760
- Single +5V +/- 10% Supply !!
- 0.95 Watts Maximum Power Dissipation @ 100% Duty Cycle !!
- Output Driver Withstands Short Circuit Fault Indefinitely with Built-In Shutdown/Recovery Circuit !!
- Proprietary Monolithic Design Provides Superior Radiation Tolerance, Reliability, Noise Performance and Thermal Impedance !!
- Total Dose Radiation Tolerance 1 Meg Rad (Si) !!
- Direct Replacements for the Popular NHI-1559 Series!!

Description:

The NHI-1579 series of Mil-Std-1553/1760 monolithic dual transceivers are available in 1.850" x .600", 36 pin plug-in and flatpack ceramic packages. It operates off of a single +5V power supply with very low standby power dissipation.

Each receiver converts the 1553 bus bi-phase data to complementary RX and RX_L TTL digital outputs for use by the manchester decoder. The device provides independent receiver enables for each channel.

The transmitters will output bi-phase manchester to the coupling transformer when the TX and TX_L inputs are driven by complementary TTL digital data. The device provides an independent transmitter inhibit TXINH for each channel.

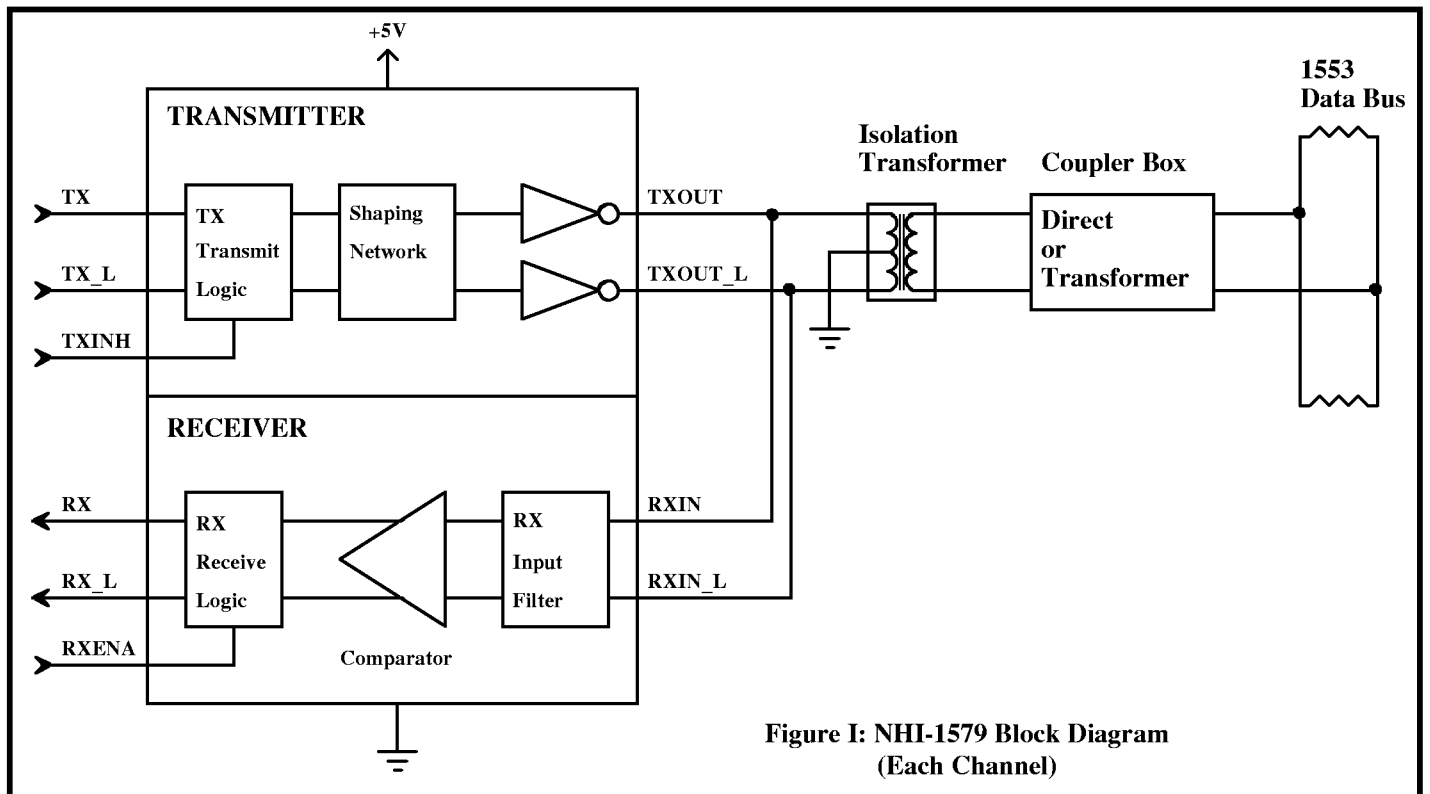

Figure I: NHI-1579 Block Diagram (Each Channel)

NHI-1579 Series

TABLE I: Electrical Specifications

Parameter	Condition	Symbol	Min	Typ	Max	Units
POWER SUPPLY REQUIREMENT		Vcc	4.5		5.5	V
TOTAL SUPPLY CURRENT	Vcc=5.0V, Not Transmitting	Icc1		70	80	mA
	Vcc=5.0V, Transmit one channel @ 50% duty cycle	Icc2		320	340	mA
	Vcc=5.0V, Transmit one channel @ 100% duty cycle	Icc3		570	615	mA
POWER DISSIPATION	Vcc=5.0V, Not Transmitting	Pd1			0.4	W
	Vcc=5.0V, Transmit one channel @ 100% duty cycle	Pd2			0.95	W
OPERATING TEMPERATURES	Junction	Tj	-55		165	°C
		Tc	-55		125	°C
	Storage	Ts	-55		165	°C
THERMAL IMPEDANCE	Junction to Case	qjc			4	°C/W
LOGIC I/O						
RXENA_A, TXA, TXA_L, TXINH_A, RXENA_B, TXB, TXB_L, TXINH_B	Vcc= 5.5V, Vil= 0.0V	Iil			-0.4	mA
	Vcc= 4.5V, Vih= 2.7V	Iih			20	uA
RXA, RXA_L, RXB, RXB_L	Vcc= 5.5V, Iol= -4mA	Vol			0.4	V
	Vcc= 4.5V, Ioh= 400 uA	Voh	2.7			V
RECEIVER						
Input Resistance	Differential	Rin	20			k W
Input Capacitance	Differential	Cin			5	pF
Common Mode Rejection Ratio		CMRR	40			dB
Input Level	Differential	Vin			40	Vpp
Receiver Delay	Zero crossing on bus to RX or RX_L	t _{RD}		250	350	nS
TRANSMITTER						
Output Voltage	Across 140 W load	V _{out}	29		36	Vpp
Rise/Fall Time	10% to 90% of peak to peak output	t _r , t _f	100	150	300	nS
Transmitter Delay	TX or TX_L edge to bus zero crossing	t _{TD}		125	150	nS
Output Dynamic Offset Voltage	Across 35 W load	V _{dyn}	-90		90	mV
Output Noise	Differential	V _{npp}			10	mVpp
Output Resistance	Differential, not transmitting	R _{out}	10			kΩ

NHI-1579 Series

Table II: Pin Functions

Pin#	Function	Pin#	Function
1	TXOUT_A	36	TXA_L
2	TXOUT_A_L	35	TXA
3	GND_A	34	TXINH_A
4	NC	33	+5V_A
5	RXA	32	NC
6	RXENA_A	31	GND_A
7	GND_A	30	RXIN_A_L
8	RXA_L	29	RXIN_A
9	NC	28	NC
10	TXOUT_B	27	TXB_L
11	TXOUT_B_L	26	TXB
12	GND_B	25	TXINH_B
13	NC	24	+5V_B
14	RXB	23	NC
15	RXENA_B	22	GND_B
16	GND_B	21	RXIN_B_L
17	RXB_L	20	RXIN_B
18	NC	19	NC

Transformer Requirements:

The NHI-1579 series requires a transformer with a turns ratio of 1:2.5 for Direct Coupling, and a turns ratio of 1:1.79 for Transformer Coupling to the Mil-Std-1553 Bus. Technitrol part number Q1553-45 or equivalent is recommended. The center tap on the transceiver side of the isolation transformer must be be grounded.

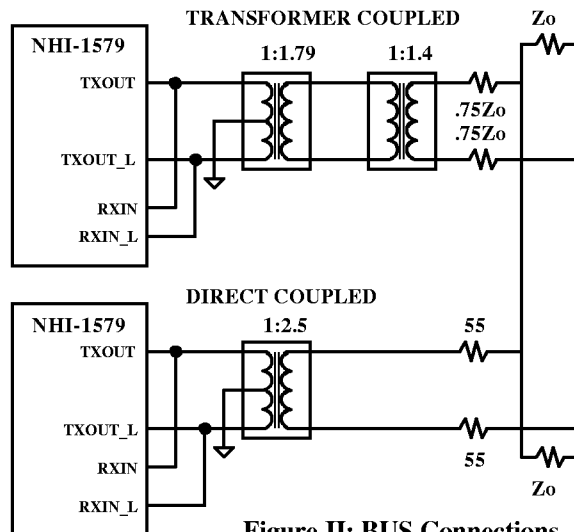
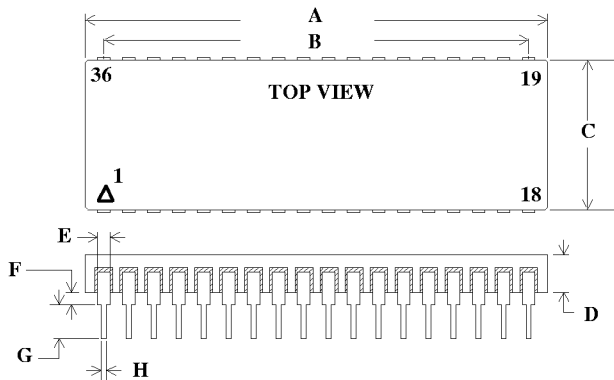
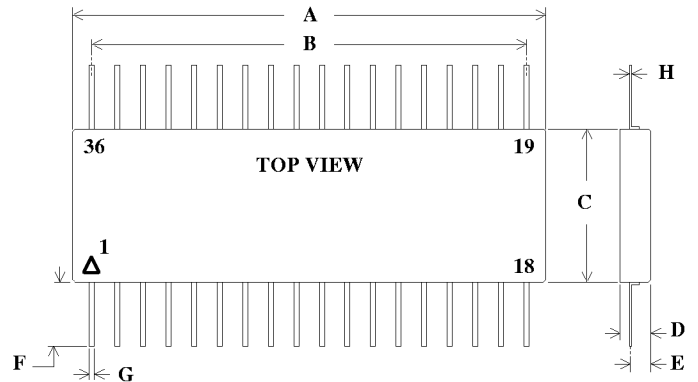

Figure II: BUS Connections



DIM	TYP (inches)	TOL (+/- inches)
A	1.850 SQ	0.015
B	17 EQ SP @	0.100 = 1.700
C	0.600	0.010
D	0.140	MAX
E	0.050	0.002
F	0.050	0.010
G	0.150	MIN
H	0.018	0.002

36 Pin Ceramic Plug-In Package Detail



DIM	TYP (inches)	TOL (+/- inches)
A	1.850 SQ	0.015
B	17 EQ SP @	0.100 = 1.700
C	0.600	0.010
D	0.120	0.012
E	0.080	0.010
F	0.500	MIN
G	0.018	0.002
H	0.010	0.002

36 Pin Ceramic Flatpack Package Detail

NHI-1579 Series

Transmit Waveforms

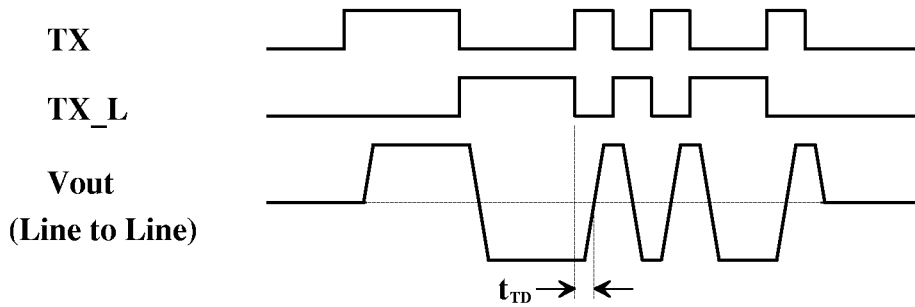

Transmitter Operation:

A high level input on TXINH will inhibit the transmitter outputs. If the TX & TX_L transmitter inputs are both high or both low, the transmitter is also inhibited. The output drivers are short circuit protected and the device will "fold back" to decrease power dissipation under this condition until the fault is removed.

Receive Waveforms

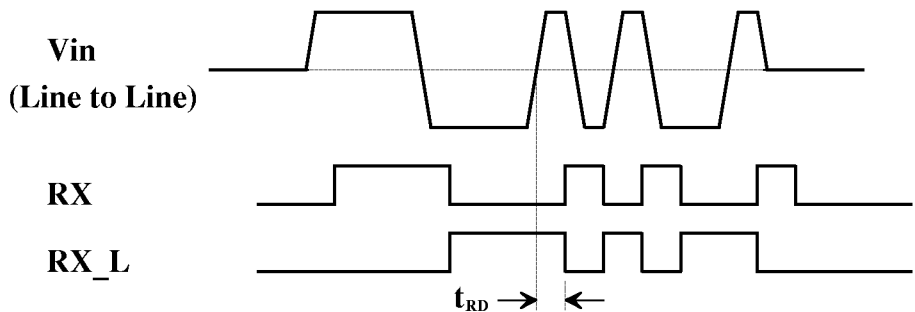

Receiver Operation:

A low level input on RXENA will disable the receiver outputs RX & RX_L regardless of bus activity. The receiver output compatibility may be specified as logic 0 or logic 1 when in standby mode.

** See Ordering Information

Ordering Information:

NHI-1579 FP / 883

Reliability Grade

883 = Fully Compliant with Mil-Std-883

M = Screened to Mil-Std-883, -55 to +125 °C

Blank = Industrial, -40 to +85 °C

Package Style

Blank = Plug-In

FP = Flatpack

Transceiver Type and Decoder Compatibility

78 = MacAir, RX & RX_L, Standby = Logic 0

79 = Mil-Std-1553, RX & RX_L, Standby = Logic 0

80 = Mil-Std-1553, RX & RX_L, Standby = Logic 1

81 = MacAir, RX & RX_L, Standby = Logic 1

** SMD Listing: DESC Drawing# 5962-92061

See QML-38534 for NHI's Manufacturer Qualification Under Mil-PRF-38534