

Low-Voltage Standard Telephone Circuit

Description

TEMIC Semiconductors' low-voltage telephone circuit, U3760MB-N, performs all the speech and line interface

functions required in an electronic telephone set tone ringer, pulse and DTMF dialing with redial.

Features

Speech Circuit

- Adjustable dc characteristic
- Symmetrical input of microphone amplifier
- Receiving amplifier for dynamic or piezo-electric earpieces
- Automatic line-loss compensation

- Selectable flashing duration by key pad
- Pause function
- Last number redial up to 32 digits
- Standard low-cost crystal 3.58 MHz or ceramic resonator

Dialer

- DTMF / pulse switchable
- Pulse dialing 66/33 or 60/40 for 10 ppS and 20 ppS or DTMF dialing selectable by pins
- Key tone

Tone Ringer

- Two-tone ringer
- Adjustable volume
- RC oscillator
- Adjustable threshold

Benefits

- Low number of external components
- High quality through one IC solution
- One IC for all standards

Ordering Information

Type	Package
U3760MB-NFN	SSO44
U3760MB-NFNG3	SSO44 tape and reel

Block Diagram / Applications

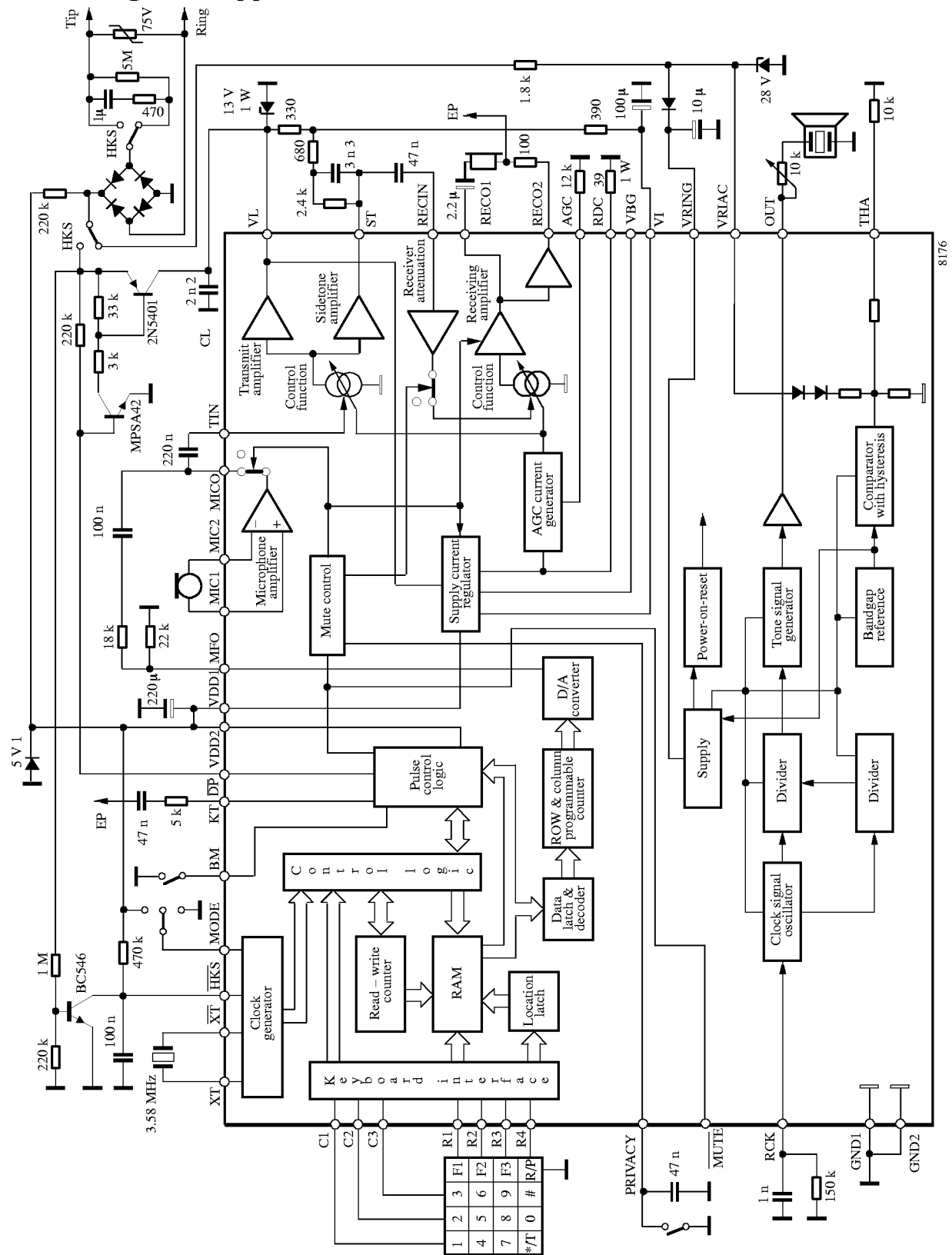
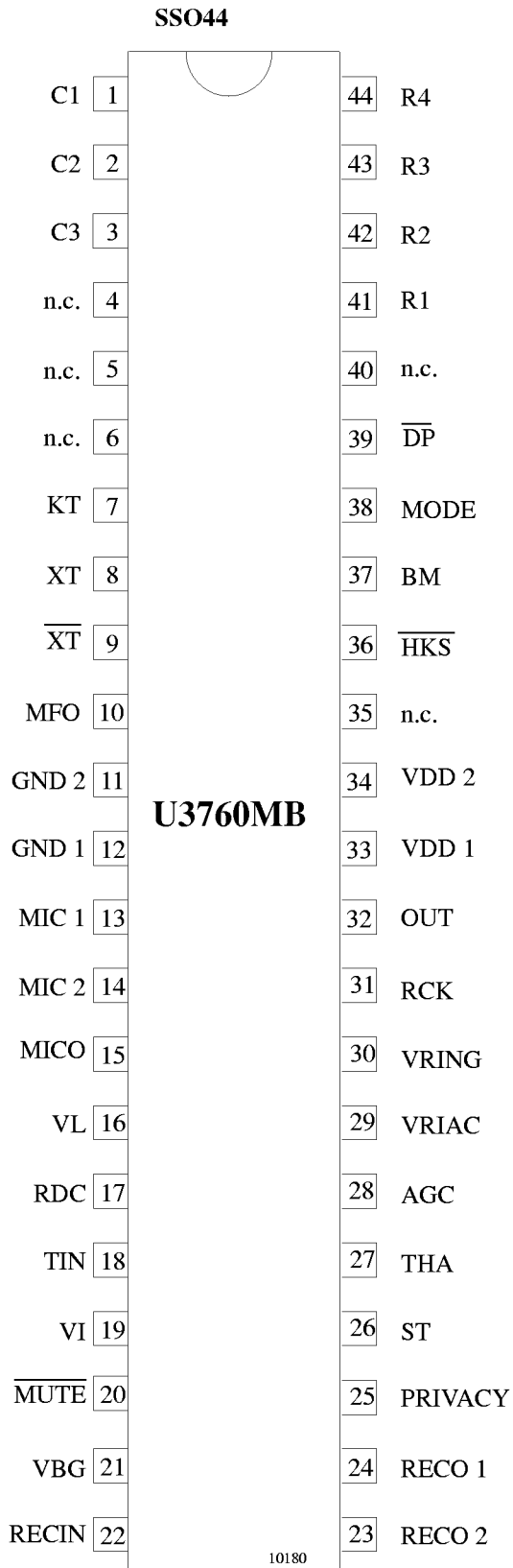

Figure 1.



Pin Description

SDIP40	SSO44	Symbol	Function	Configuration																																
1	1	C1	Keyboard input																																	
2	2	C2																																		
3	3	C3																																		
15	4, 5, 6, 35	NC	Not connected																																	
4	7	KT	Key tone signal output generated for all keys in pulse dialing mode (except Flash + Redial) with a frequency of about 1240 Hz and duration about 50 ms																																	
5	8	XT	A built-in inverter provides oscillation with an inexpensive 3.579545 MHz crystal or ceramic resonator																																	
6	9	$\overline{\text{XT}}$																																		
7	10	MFO	Output of DTMF DTMF output frequency <table border="1" style="margin-left: 20px;"> <thead> <tr> <th></th> <th>Specified (HZ)</th> <th>Actual (Hz)</th> <th>Error (%)</th> </tr> </thead> <tbody> <tr> <td>R1</td> <td>697</td> <td>699</td> <td>+0.28</td> </tr> <tr> <td>R2</td> <td>770</td> <td>766</td> <td>-0.52</td> </tr> <tr> <td>R3</td> <td>852</td> <td>848</td> <td>-0.47</td> </tr> <tr> <td>R4</td> <td>941</td> <td>948</td> <td>+0.74</td> </tr> <tr> <td>C1</td> <td>1209</td> <td>1216</td> <td>+0.57</td> </tr> <tr> <td>C2</td> <td>1336</td> <td>1332</td> <td>-0.30</td> </tr> <tr> <td>C3</td> <td>1477</td> <td>1472</td> <td>-0.34</td> </tr> </tbody> </table>		Specified (HZ)	Actual (Hz)	Error (%)	R1	697	699	+0.28	R2	770	766	-0.52	R3	852	848	-0.47	R4	941	948	+0.74	C1	1209	1216	+0.57	C2	1336	1332	-0.30	C3	1477	1472	-0.34	
	Specified (HZ)	Actual (Hz)	Error (%)																																	
R1	697	699	+0.28																																	
R2	770	766	-0.52																																	
R3	852	848	-0.47																																	
R4	941	948	+0.74																																	
C1	1209	1216	+0.57																																	
C2	1336	1332	-0.30																																	
C3	1477	1472	-0.34																																	
9	12	GND 1	Ground 1 connected with ground 2																																	
8	11	GND 2																																		

SDIP40	SSO44	Symbol	Function	Configuration
10	13	MIC 1	Inverting input of microphone amplifier	
11	14	MIC 2	Non-inverting input of microphone amplifier	
12	15	MICO	Transmit pre-amp output which is normally capacitively coupled to Pin TIN	
13	16	VL	Positive supply voltage input to the device. The current through this pin is modulated by the transmit signal.	
14	17	RDC	An external resistor (1 W) is required from this pin to GND to control the dc input impedance of the circuit. It has a nominal value of 39 Ω for low-voltage operation. Values up to 100 Ω may be used to increase the available transmit output voltage swing at the expense of low-voltage operation.	
16	18	TIN	Input to the line output driver amplifier. Transmit AGC applied to this stage.	
17	19	V _I	This internal voltage bias line must be connected to VL via an external resistor, R _B , which dominates the ac input impedance of the circuit and should be 680 Ω for an 600 Ω input impedance or 1.2 k Ω for a 900 Ω input impedance.	

SDIP40	SSO44	Symbol	Function	Configuration
18	20	MUTE	Pin for testing	
19	21	VBG	Pin for test mode	
20	22	RECIN	Receive amplifier input. The receiving amplification is regulated by an AGC.	
22	24	RECO1	Output of the receive amplifier. Dynamic transducers with a minimum impedance of 100 Ω can be directly driven by these outputs.	
21	23	RECO2		
23	25	PRIVACY	Input for handset mute	
24	26	ST	The output of the sidetone cancellation signal, which requires a balanced impedance of 8 to 10 times the subscribers line impedance to be connected to Pin VL.	
25	27	THA	Ringer threshold adjustment	
26	28	AGC	The range of transmit and receive gain variations between short and long loops may be adjusted by connecting a resistor R _{AGC} from this pin to (GND). This pin can be left open to set AGC out of action.	
27	29	VRIAC	Ringing supply	

SDIP40	SSO44	Symbol	Function	Configuration
28	30	VRING	DC supply voltage for the tone ringer is limited to 30 V with integrated Z-diode.	
29	31	RCK	RC clock oscillator for ringer	
30	32	OUT	Buzzer output	
31	33	VDD 1	Supply output for dialer part	
32	34	VDD 2	Supply input of dialer section	
33	36	$\overline{\text{HKS}}$	Hook switch input. $\overline{\text{HKS}} = 1$: On-hook state. Chip in sleep mode, no operation. $\overline{\text{HKS}} = 0$: Off-hook state. Chip enable for normal operation.	
34	37	BM	If BM = floating pulse dialing with 3:2 B/M ratio If BM is connected to ground pulse dialing with a B/M ratio of 2:1	
35	38	MODE	Pulling mode pin to V_{DD} places the dialer in tone mode. Pulling mode pin to GND places the dialer in pulse mode (20 ppS). If the mode pin is left floating, the dialer is in pulse mode (10 ppS)	
36	39	$\overline{\text{DP}}$	N-channel open drain pulse dialing output. Flash key will cause $\overline{\text{DP}}$ to be active in either DTMF mode or pulse mode.	

SDIP40	SSO44	Symbol	Function	Configuration
37	41	R1	Keyboard input	
38	42	R2		
39	43	R3		
40	44	R4		

Keyboard Operation

C1	C2	C3		
1	2	3	F1	R1
4	5	6	F2	R2
7	8	9	F3	R3
* / T	0	#	R / P	R4

┆

- * / T: * and pulse-to-tone key
- R / P: Redial and pause function key
- F1, F2, F3: Flash keys

Normal Dialing

OFF HOOK , D1 , D2 , ..., Dn

1. D1, D2, ..., Dn will be dialed out.
2. Dialing length is unlimited, but redial is inhibited if length oversteps 32 digits.

Redialing

OFF HOOK , D1 , D2 , ..., Dn BUSY, Come ON HOOK , OFF HOOK , R / P

The R / P key can execute the redial function only as the first key-in after off-hook; otherwise, it executes the pause function.

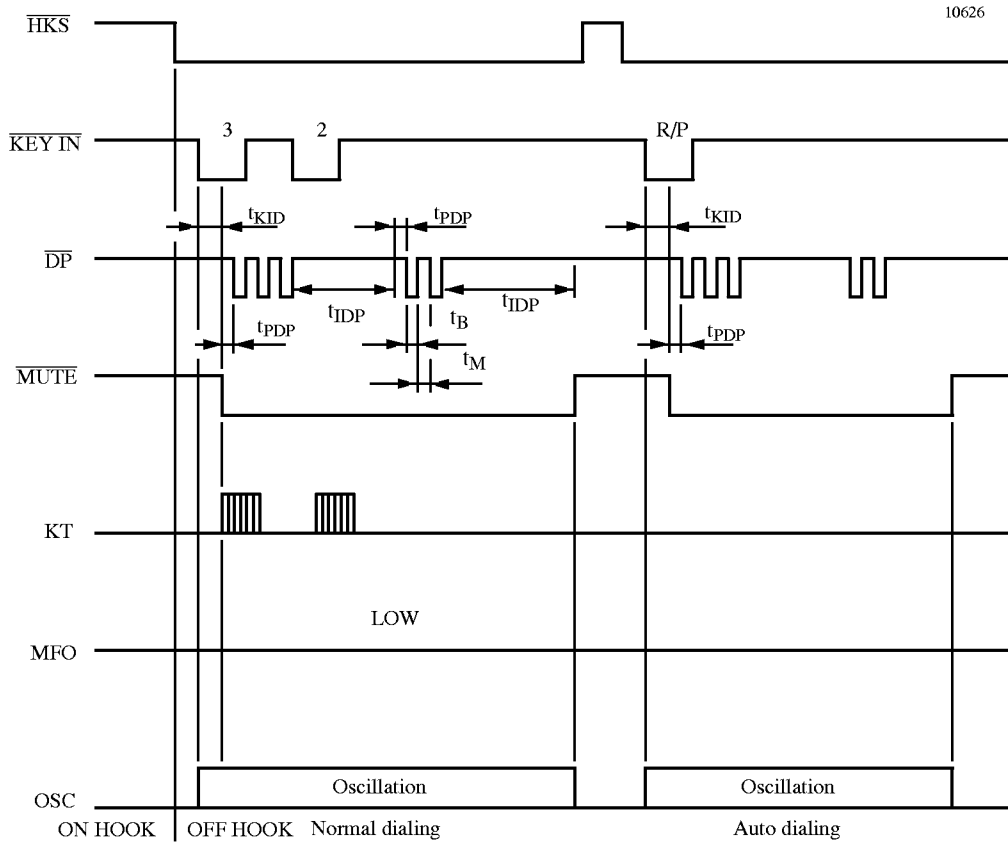

Figure 2. Pulse mode

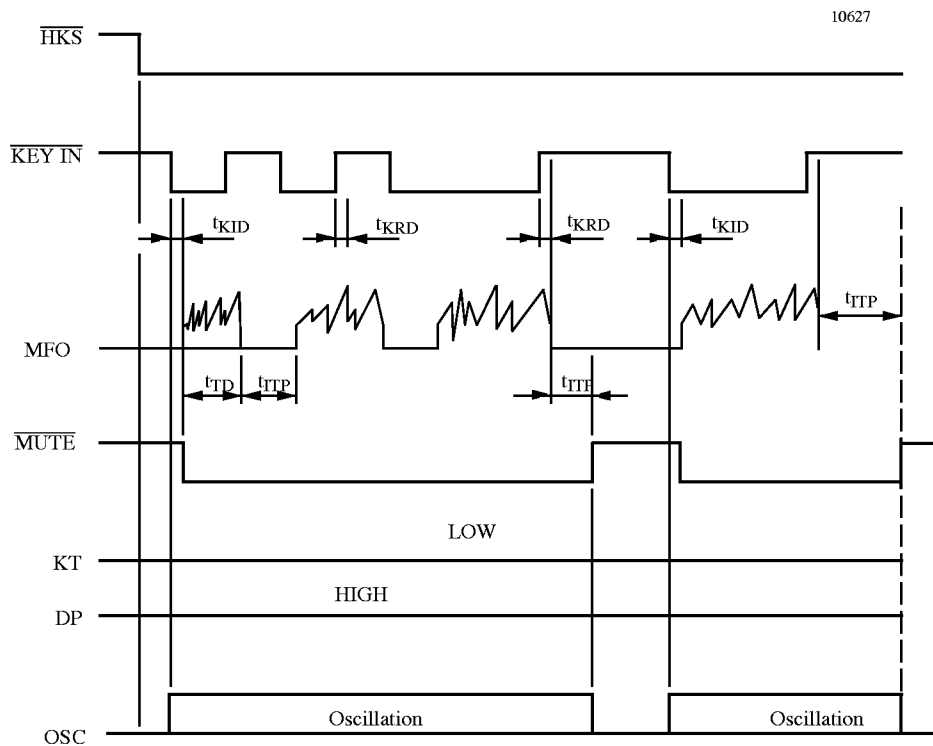

Figure 3. DTMF mode normal dialing

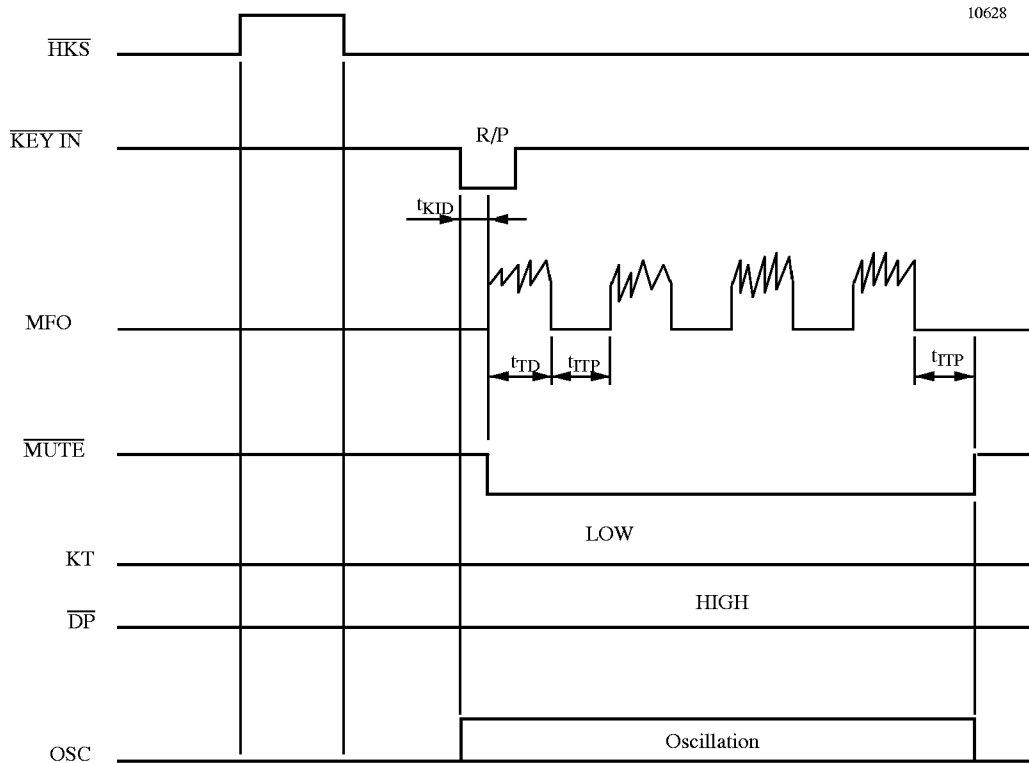

Figure 4. DTMF auto dialing

Access Pause

OFF HOOK , D1 , D2 , R/P , D3 , ..., Dn'

1. The pause function can be stored in memory.
2. The pause function is executed in normal dialing and redialing.

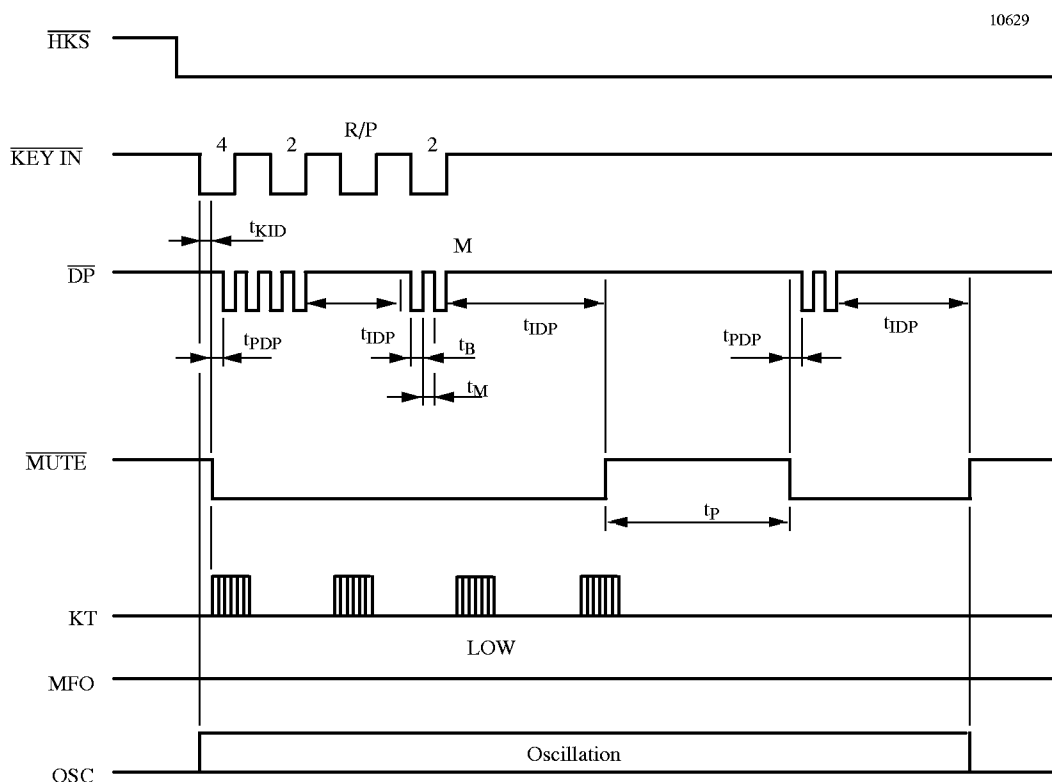

Figure 5. Pause function

Pulse-to-Tone (* / T)

OFF HOOK , D1 , D2 , ..., Dn , * / T , D1' , D2' , ..., Dn'

1. If the mode switch is set to pulse mode, then the output signal will be:

D1, D2, ..., Dn, Pause (3.6 s), D1', D2', ..., Dn'

(Pulse) (Tone)

2. If the mode switch is set to tone mode, then the output signal will be:

D1, D2, ..., Dn, * , D1', D2', ..., Dn'

(Tone) (Tone) (Tone)

3. The dialer remains in tone mode when the digits have been dialed out and can be reset to pulse mode only by going on-hook.

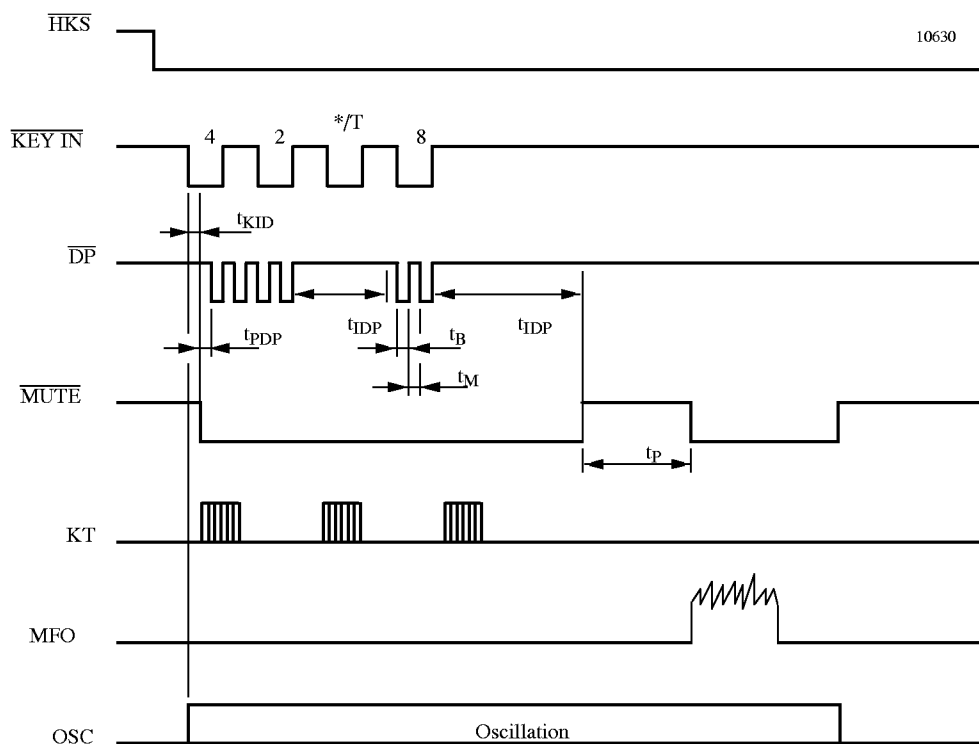

Figure 6. Pulse-to-tone operation

Flash (F1 or F2 or F3)

OFF HOOK , F_n

1. The flash key cannot be stored as a digit in memory. The flash key has first priority among the keyboard functions.
2. The system will return to the initial state after the flash pause time is finished.

OFF HOOK , F_n , D1 , D2 , D3 , ..., Dn

LNB = D1, D2, D3, ..., Dn

OFF HOOK , D1 , D2 , F_n , D3 , ..., Dn

LNB = D3, ..., Dn

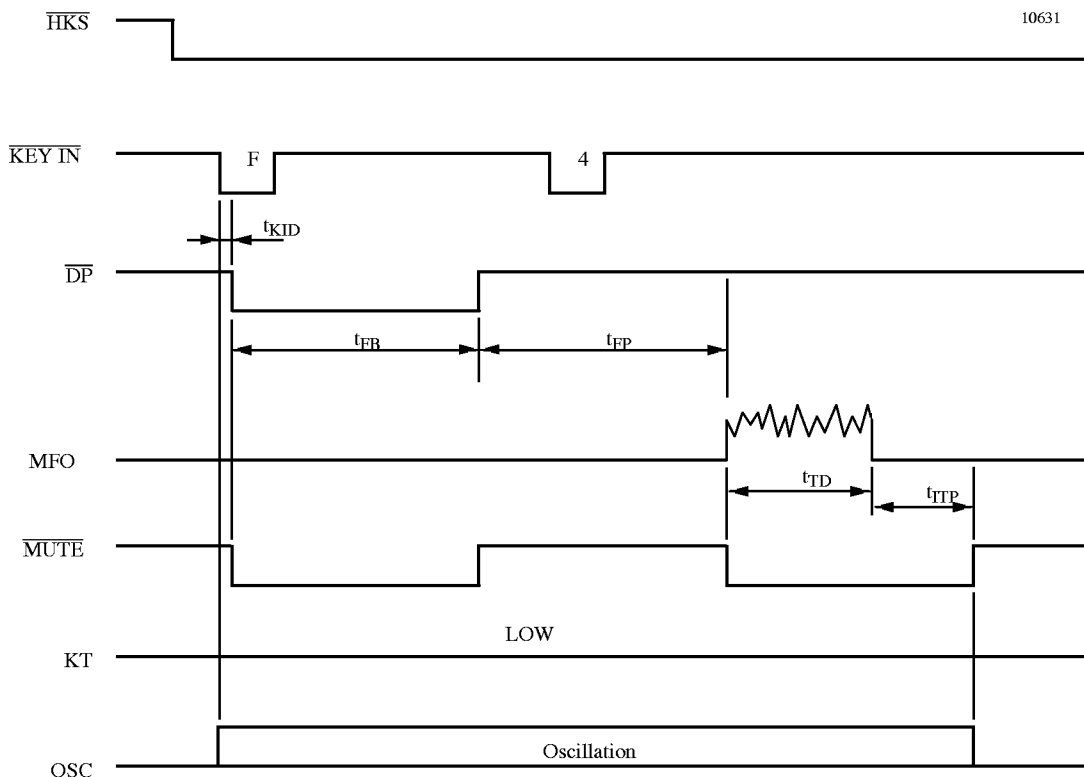

Figure 7. Flash operation

t_{KID} = key active in debounce
 t_{KRD} = key release debounce
 t_{PDP} = pre-digit pause
 t_{IDP} = inter-digit pause
 t_{TD} = DTMF output duration

t_{TP} = intertone pause
 t_{FB} = flash break time
 t_{FP} = flash pause time
 t_p = pause time

Absolute Maximum Ratings

Parameters	Symbol	Value	Unit	
Line current	I_L	140	mA	
DC line voltage	V_L	14	V	
Junction temperature	T_j	125	°C	
Ambient temperature	T_{amb}	-25 to +75	°C	
Storage temperature	T_{stg}	-55 to +150	°C	
Total power dissipation, $T_{amb} = 60^\circ\text{C}$	P_{tot}	SSO44	0.9	W
SDIP40		1.3		
Junction ambient	R_{thJA}	SSO44	70	k/W
SDIP40		50		

Electrical Characteristics Speech Circuit

Reference point Pin GND, $f = 1000\text{ Hz}$, $0\text{ dBm} = 775\text{ mV}_{rms}$, $R_{DC} = 39\ \Omega / 1\text{ W}$, $T_{amb} = 25^\circ\text{C}$, unless otherwise specified

Parameters	Test Conditions / Pin	Symbol	Min.	Typ.	Max.	Unit
Line voltage	$I_L = 5\text{ mA}$	V_L	1.2		1.5	V
	$I_L = 20\text{ mA}$			4.0		V
	$I_L = 30\text{ mA}$			4.5		V
	$I_L = 73\text{ mA}$			6.4		V
Transmit and sidetone						
Input resistance	R_i	R_i	45	80	120	k Ω
Gain	$I_L = 20\text{ mA}$, S5 = open	G_s	46.8	47.8	48.8	dB
Line-loss compensation	$R_{AGC} = 12\text{ k}\Omega$, $I_L = 73\text{ mA}$	ΔG_s	-4.8	-6	-7	dB
Noise at line weighted psophometrically	$I_L > 20\text{ mA}$, $G_s = 48\text{ dB}$	n_o			-72	dBmp
Sidetone reduction	$I_L \geq 20\text{ mA}$	G_{STA}	10	15	20	dB
DTMF amplifier						
Volume range $d < 5\%$	Single tone, $I_L \geq 20\text{ mA}$	V_L	1.3			dBm
DTMF output level low frequency group	$I_L = 20\text{ mA}$, S5 = closed	V_L	-8		-4	dBm
Pre-emphasis between high and low level frequency group	$P_{PRE} = P_{HLG} - P_{LLG}$, S5 = closed	P_{PRE}	1		3	dB
Receiving amplifier						
Gain	$I_L \geq 20\text{ mA}$	G_R	3		5	dB
Line-loss compensation	$I_L = 73\text{ mA}$	ΔG_R	-4.7	-6	-7	dB
Receiving noise at ear-phone weighted psophometrically	$I_L = 73\text{ mA}$	n_i		-77.5	-71	dBm
Gain change when muted	$I_L \geq 20\text{ mA}$	G_{RM}	24	29	34	dB
Output voltage push-pull	$I_L \geq 20\text{ mA}$, $Z_{ear} = 68\text{ nF}$, $100\ \Omega$ in series	V_{RECO}	0.8	0.9		V_{RMS}
Supply voltage (for internal use only)						
Output voltage	$I_L \geq 20\text{ mA}$ dialing mode	V_{DD1}	2.3		6.3	V

DC Characteristics Dialer

$V_{DD2} = 2.7$ V, $f_{OSC} = 3.58$ MHz, all outputs unloaded, S9b

Parameters	Test Conditions / Pins	Symbol	Min.	Typ.	Max.	Unit
Memory retention current	$\overline{HKS} = 1, V_{DD2} = 1.0$ V	I_{MR}			0.2	μ A
Pre-emphases	Column/Row		1	2	3	dB
DTMF distortion	$R_L = 5$ k Ω	d		-30	-23	dB
DP output sink current	$V_{PO} = 0.5$ V	I_{PL}	0.5			mA
Keyboard input drive current	$V_I = 0$ V	I_{KD}	30			μ A
Keyboard input sink current	$V_I = 2.7$ V	I_{KS}	200	400		μ A
Keyboard resistance					5	k Ω
Key tone output current				± 1		mA
Key tone frequency	$t = 50$ ms			1240		Hz

AC Characteristics Dialer

Parameters	Test Conditions / Pins	Symbol	Min.	Typ.	Max.	Unit
Keypad active in debounce		t_{KID}		20		ms
Key release debounce		t_{KRD}		20		ms
Pre-digit pause	B/M pin = floating	t_{PDP}		40		ms
	B/M pin = low	t_{PDP}		33.3		ms
Inter-digit pause (auto dialing)	10 ppS	t_{IDP}		800		ms
	20 ppS	t_{IDP}		500		ms
Make/break ratio	B/M pin = floating	M/B		40:60		%
	B/M pin = low			33:67		%
DTMF output duration	Auto dialing	t_{TD}		87		ms
Inter-tone pause	Auto dialing	t_{TTP}		87		ms
Flash break time	F1	t_{FB}		94		ms
	F2			250		ms
	F3			600		ms
Flash pause time	F1	t_{FP}		1.0		s
	F2					
	F3					
Pause time		t_p		3.6		

Electrical Characteristics Tone Ringer

$f_{RCK} = 4 \text{ kHz}$, $V_{RING} = 20 \text{ V}$, $T_{amb} = 25^\circ\text{C}$, reference point GND, unless otherwise specified

Parameters	Test Conditions / Pins	Symbol	Min.	Typ.	Max.	Unit
Supply current, outputs open	$V_{RIAC} = 20 \text{ V}$	I_{RING}	2.1		3.8	mA
Switch-on threshold	V_{RIAC}	V_{Ron}		23.5		V
Switch-off threshold	V_{RIAC}	V_{Roff}		5.6		V
Ringing frequency	$R = 150 \text{ k}\Omega$, $C = 1 \text{ nF}$ $V_{RIAC} > V_{RON}$	f_{1H}	937	1010	1083	Hz
		f_{1L}	752	808	868	Hz
Audio sequence frequency		f_2		12.5		Hz
Turn-off delay	See figure 8	t_{off}		65		ms

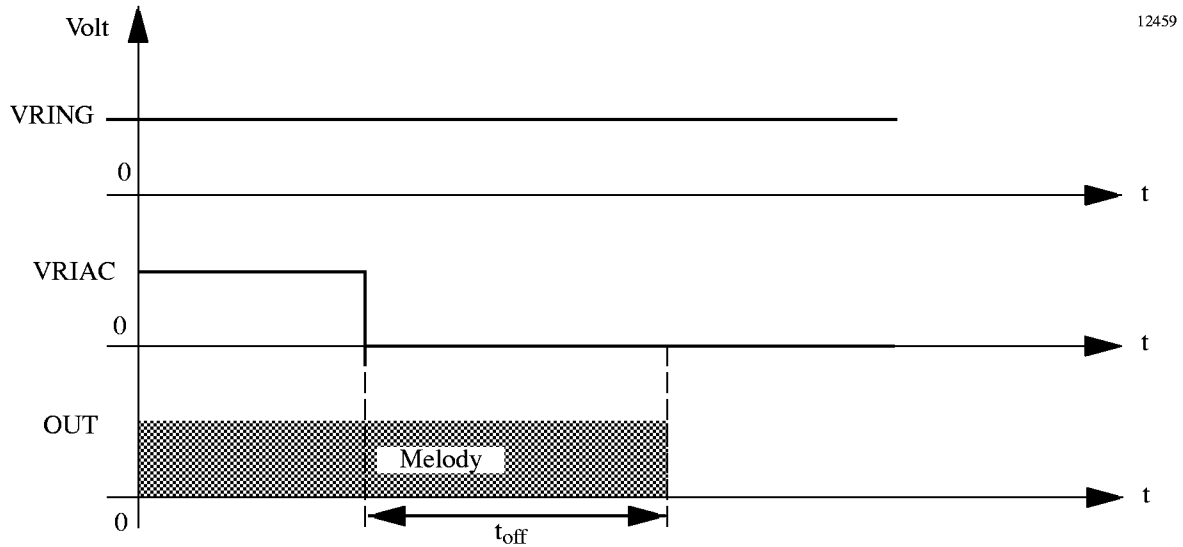

Figure 8. Turn off delay time

Formulas for Parameters of Electrical Characteristics of Speech Circuit

Formulas referred to the basic test circuit. If not otherwise specified switches in basic test circuit are inactive.

Transmit gain

$$GS = 20 \times \log \left(\frac{VL}{VMIC} \right)$$

VMIC = 3 mV/1 kHz, S5 = open

Receiving gain

$$GR = 20 \times \log \left(\frac{VRECO}{VL} \right)$$

RX-mode: VGEN = 300 mV/1 kHz, S7b

Line loss compensation transmit

$$\Delta GS = GS(\text{at IL} = 73 \text{ mA}) - GS(\text{at IL} = 20 \text{ mA})$$

TX-mode: VMIC = 3 mV/1 kHz, S5 = open

Sidetone reduction

$$GSTA = 20 \times \log \left(\frac{VL}{VRECO} \right) (\text{in TX-mode}) + GR$$

TX-mode: VMIC = 3 mV/1 kHz, S5 = open

Line loss compensation receive

$$\Delta GR = GR(\text{at IL} = 73 \text{ mA}) - GR(\text{at IL} = 20 \text{ mA})$$

RX-mode: VGEN = 300 mV/1 kHz, S7b

Gain change when muted

$$GRM = 20 \times \log \frac{VRECO}{VL} (\text{Mute} = \text{inactive}) - 20 \times \log \frac{VRECO}{VL} (\text{Mute} = \text{active})$$

VGEN = 100 mV/1 kHz, S5 = open, S8 = open

Input impedance of microphone amplifier

$$Ri = \frac{50 \text{ k}}{\left(\frac{VL_{(S6 = \text{closed})}}{VL_{(S6 = \text{open})}} - 1 \right)}$$

TX-mode: VMIC = 3 mV/1 kHz, S5 = open

Package Information

Package SSO44

Dimensions in mm

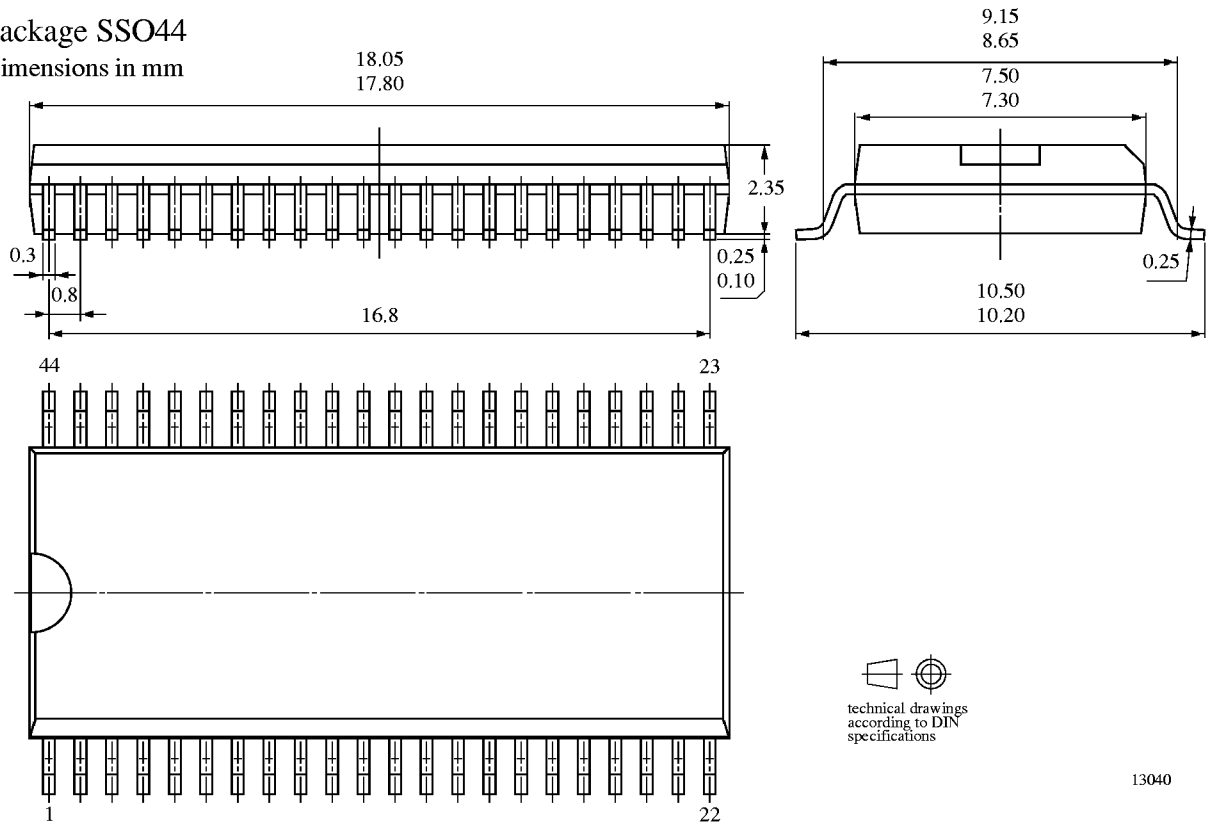

13040

Ozone Depleting Substances Policy Statement

It is the policy of **TEMIC Semiconductor GmbH** to

1. Meet all present and future national and international statutory requirements.
2. Regularly and continuously improve the performance of our products, processes, distribution and operating systems with respect to their impact on the health and safety of our employees and the public, as well as their impact on the environment.

It is particular concern to control or eliminate releases of those substances into the atmosphere which are known as ozone depleting substances (ODSs).

The Montreal Protocol (1987) and its London Amendments (1990) intend to severely restrict the use of ODSs and forbid their use within the next ten years. Various national and international initiatives are pressing for an earlier ban on these substances.

TEMIC Semiconductor GmbH has been able to use its policy of continuous improvements to eliminate the use of ODSs listed in the following documents.

1. Annex A, B and list of transitional substances of the Montreal Protocol and the London Amendments respectively
2. Class I and II ozone depleting substances in the Clean Air Act Amendments of 1990 by the Environmental Protection Agency (EPA) in the USA
3. Council Decision 88/540/EEC and 91/690/EEC Annex A, B and C (transitional substances) respectively.

TEMIC Semiconductor GmbH can certify that our semiconductors are not manufactured with ozone depleting substances and do not contain such substances.

We reserve the right to make changes to improve technical design and may do so without further notice.

Parameters can vary in different applications. All operating parameters must be validated for each customer application by the customer. Should the buyer use TEMIC Semiconductors products for any unintended or unauthorized application, the buyer shall indemnify TEMIC Semiconductors against all claims, costs, damages, and expenses, arising out of, directly or indirectly, any claim of personal damage, injury or death associated with such unintended or unauthorized use.

TEMIC Semiconductor GmbH, P.O.B. 3535, D-74025 Heilbronn, Germany
Telephone: 49 (0)7131 67 2594, Fax number: 49 (0)7131 67 2423