

SPECIFICATIONS
 Crimped Ferrule
 Hex Crimp Size 128"
 Contact Pin To Solder

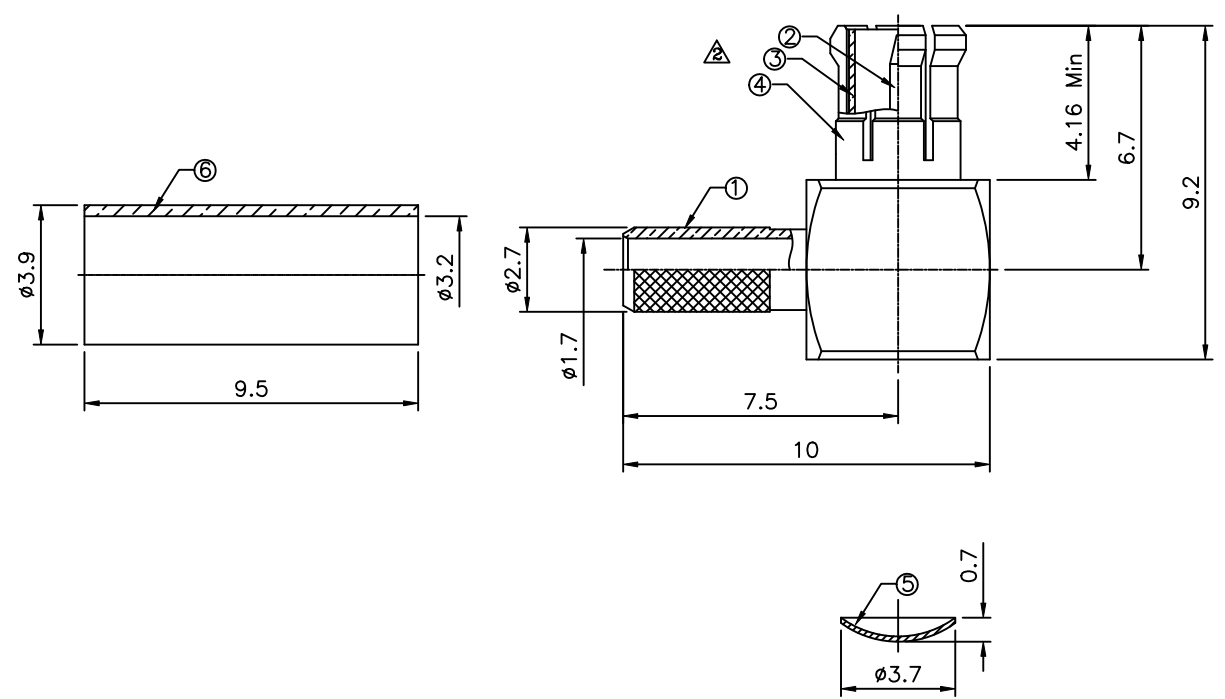
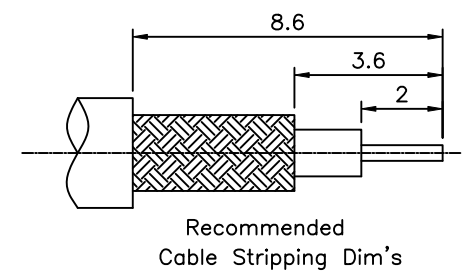

Notes: Finish (Plating Thickness In Micro-Inches)
 1. Brass PER QQ-B-626
 2. Gold 3 Min Over Nickel PL 70 Min Thick Over Copper Strike
 3. Gold PL 30 Min Over Nickel PL 70 Min Thick Over Copper Strike
 4. Teflon MIL-P-19468
 5. Beryllium Copper PER QQ-C-530
 6. Brass JIS H 3250 C 2700

6	Ferrule	Note 6	Note 2
5	Cover	Note 1	Note 2
4	Contact Body	Note 5	Note 2
3	Insulator	Note 4	White
2	Contact Pin	Note 1	Note 3
1	Cube Body	Note 1	Note 2
No.	Description	Material	Finish

AUK A MEMBER OF AUK GROUP
太聯事業股份有限公司
AUK CONTRACTORS CO., LTD.

CATEGORY		APPROVED BY		UNLESS OTHERWISE SPECIFIED TOLERANCES ARE 0.5~6 ±0.2 >6~30 ±0.4 >30~120 ±0.6 >120~315 ±1 >315~1000 ±1.6 ANG ±5°
PART No. △ MCX-PCR17450		MEI		
DRAWING No. MCX-PCR17450		HZF		
SCALE NONE		REV. A2		
CHECKED BY		DRAWING BY		UNIT mm
HZF		PEGA		
NO. REV.		REVISIONS		CHK DATE

△ A2	Add Part Number	HZF	05/06/2008
△ A1	Modify Part No.	INGRID	04/28/2008
△ A0	NEW RELEASE	HZF	04/25/2006
NO. REV.	REVISIONS	CHK	DATE