



DM54148 Priority Encoder

General Description

This TTL encoder features priority decoding of the input data to ensure that only the highest-order data line is encoded. The DM54148 encodes eight data lines to three-line (4-2-1) binary (octal). Cascading circuitry (enable input E1 and enable output E0) has been provided to allow octal expansion without the need for external circuitry. For all types, data inputs and outputs are active at the low logic level.

Features

- Encodes 8 data lines to 3-line binary (octal)
- Applications include:
 - N-bit encoding
 - Code converters and generators

Connection Diagram

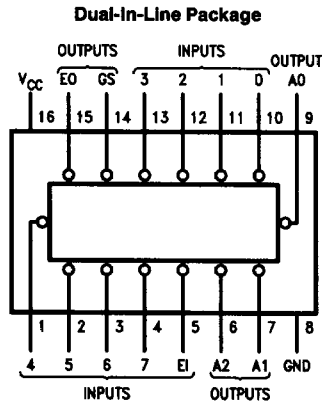

TL/F/6545-1

Order Number **DM54148J** or **DM54148W**
 See NS Package Number **J16A** or **W16A**

Function Table

DM54148

E1	Inputs								Outputs				
	0	1	2	3	4	5	6	7	A2	A1	A0	GS	E0
H	X	X	X	X	X	X	X	X	H	H	H	H	H
L	H	H	H	H	H	H	H	H	H	H	H	H	L
L	X	X	X	X	X	X	X	L	L	L	L	L	H
L	X	X	X	X	X	X	L	H	L	L	H	L	H
L	X	X	X	X	L	H	H	H	L	H	H	L	H
L	X	X	X	L	H	H	H	H	H	L	L	L	H
L	X	X	L	H	H	H	H	H	H	L	H	L	H
L	X	L	H	H	H	H	H	H	H	H	L	L	H
L	L	H	H	H	H	H	H	H	H	H	H	L	H

H = High Logic Level, L = Low Logic Level, X = Don't Care

Absolute Maximum Ratings (Note)

If Military/Aerospace specified devices are required, please contact the National Semiconductor Sales Office/Distributors for availability and specifications.

Supply Voltage	7V
Input Voltage	5.5V
Operating Free Air Temperature Range DM54	-55°C to +125°C
Storage Temperature Range	-65°C to +150°C

Note: The "Absolute Maximum Ratings" are those values beyond which the safety of the device cannot be guaranteed. The device should not be operated at these limits. The parametric values defined in the "Electrical Characteristics" table are not guaranteed at the absolute maximum ratings. The "Recommended Operating Conditions" table will define the conditions for actual device operation.

Recommended Operating Conditions

Symbol	Parameter	DM54148			Units
		Min	Nom	Max	
V _{CC}	Supply Voltage	4.5	5	5.5	V
V _{IH}	High Level Input Voltage	2			V
V _{IL}	Low Level Input Voltage			0.8	V
I _{OH}	High Level Output Current			-0.8	mA
I _{OL}	Low Level Output Current			16	mA
T _A	Free Air Operating Temperature	-55		125	°C

Electrical Characteristics over recommended operating free air temperature range (unless otherwise noted)

Symbol	Parameter	Conditions	Min	Typ (Note 1)	Max	Units
V _I	Input Clamp Voltage	V _{CC} = Min, I _I = -12 mA			-1.5	V
V _{OH}	High Level Output Voltage	V _{CC} = Min, I _{OH} = Max V _{IL} = Max, V _{IH} = Min	2.4			V
V _{OL}	Low Level Output Voltage	V _{CC} = Min, I _{OL} = Max V _{IH} = Min, V _{IL} = Max			0.4	V
I _I	Input Current @Max Input Voltage	V _{CC} = Max, V _I = 5.5V			1	mA
I _{IH}	High Level Input Current	V _{CC} = Max V _I = 2.4V	0 Input		40	μA
			Others		80	
I _{IL}	Low Level Input Current	V _{CC} = Max V _I = 0.4V	0 Input		-1.6	mA
			Others		-3.2	
I _{OS}	Short Circuit Output Current	V _{CC} = Max (Note 2)	-35		-85	mA
I _{CC1}	Supply Current	V _{CC} = Max (Note 3)		40	60	mA
I _{CC2}	Supply Current	V _{CC} = Max (Note 4)		35	55	mA

Note 1: All typicals are at V_{CC} = 5V, T_A = 25°C.

Note 2: Not more than one output should be shorted at a time.

Note 3: I_{CC1} is measured with inputs E1 and 7 grounded, other inputs and outputs open.

Note 4: I_{CC2} is measured with all inputs and all outputs open.

Switching Characteristics at $V_{CC} = 5V$ and $T_A = 25^\circ C$ (See Section 1 for Test Waveforms and Output Load)

Symbol	Parameter	From (Input) To (Output)	Waveform	$R_L = 400\Omega, C_L = 15\text{ pF}$		Units
				Min	Max	
t_{PLH}	Propagation Delay Time Low to High Level Output	0 thru 7 to A0, 1, 2	In-Phase Output		15	ns
t_{PHL}	Propagation Delay Time High to Low Level Output	0 thru 7 to A0, 1, 2			14	ns
t_{PLH}	Propagation Delay Time Low to High Level Output	0 thru 7 to A0, 1, 2	Out-of-Phase Output		19	ns
t_{PHL}	Propagation Delay Time High to Low Level Output	0 thru 7 to A0, 1, 2			19	ns
t_{PLH}	Propagation Delay Time Low to High Level Output	0 thru 7 to E0	Out-of-Phase Output		10	ns
t_{PHL}	Propagation Delay Time High to Low Level Output	0 thru 7 to E0			25	ns
t_{PLH}	Propagation Delay Time Low to High Level Output	0 thru 7 to GS	In-Phase Output		30	ns
t_{PHL}	Propagation Delay Time High to Low Level Output	0 thru 7 to GS			25	ns
t_{PLH}	Propagation Delay Time Low to High Level Output	E1 to A0, 1, 2	In-Phase Output		16	ns
t_{PHL}	Propagation Delay Time High to Low Level Output	E1 to A0, 1, 2			15	ns
t_{PLH}	Propagation Delay Time Low to High Level Output	E1 to GS	In-Phase Output		13	ns
t_{PHL}	Propagation Delay Time High to Low Level Output	E1 to GS			15	ns
t_{PLH}	Propagation Delay Time Low to High Level Output	E1 to E0	In-Phase Output		15	ns
t_{PHL}	Propagation Delay Time High to Low Level Output	E1 to E0			30	ns

Logic Diagram

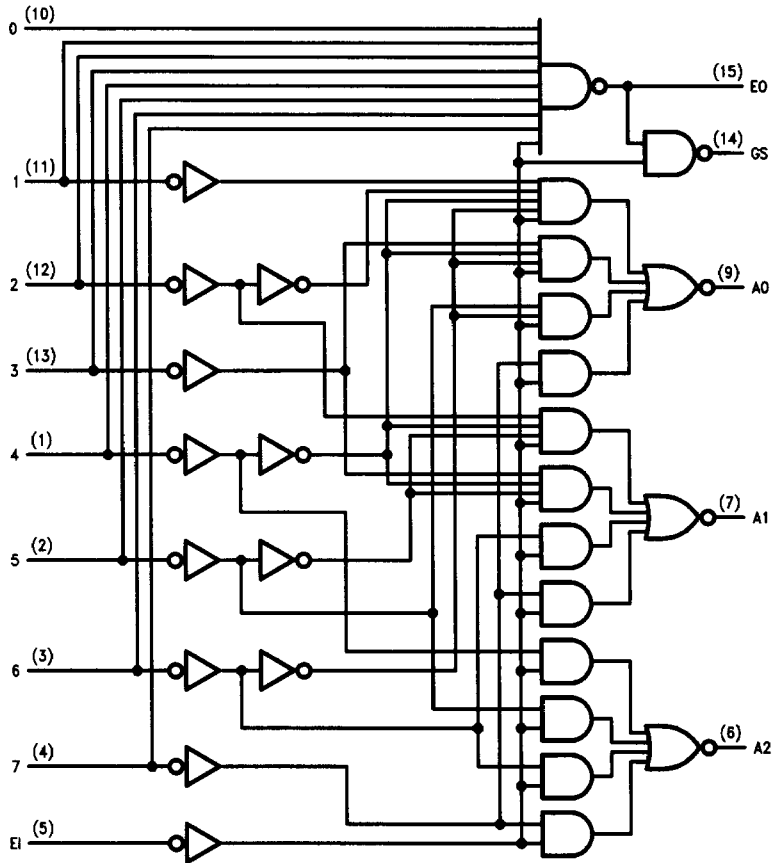

TL/F/6545-2