

Surface Mounted Type Transformers



Outline

Power supply systems of electronic devices are currently shifting from the traditional integrated-type to the new distributed-type. In this age of high-density integration of electronic devices, smaller and thinner transformers are becoming more indispensable. In answer to these needs, we, at TOKIN, are introducing a wide line-up of surface-mounted transformers.

Features

- Small and thin construction, high inductance
- Multi-terminal construction, can be surface-mounted
- Can be mounted with an automatic mounting machine

Applications

- ISDN
- Various electronic equipment

Standard Material Characteristics of Cores

Material Name			BH1
Initial permeability	μ_i		2300±20%
Effective saturation magnetic flux density	B _{ms}	(mT)	510
Effective retentivity	B _{rms}	(mT)	100
Effective coercivity	H _{cms}	(A / m)	14.3
Core loss	P _{cv}	1MHz 50mT (kW / m ³)	450 (60°C) 410 (100°C)
Curie temperature	T _c	(°C)	220
Density	d	(kg / m ³)	4.8 × 10 ³

Typical Circuit

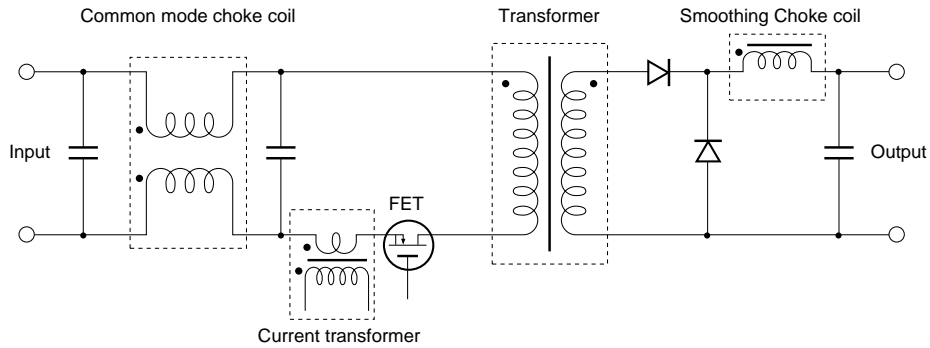

Specifications

Power capacity	Transformer model	Smoothing Choke coil 300kHz		Common Mode Choke Coil 300kHz		Current Transformer 300kHz	
	300kHz	Rated Current	Model	Rated Current	Model	Rated Current	Model
0.6W	FEE5	0.12A	FEE5	0.50A	FEE5	1.00A	FEE5
3W	FEY9.1	0.60	FEY9.1				
10W	FEY12.8	2.00	FEY12.8				
15W	FEY15.3	3.00	FEY15.3				
20W	FEE14	4.00	FEE14	2.00A	FED11.6/5	—	
30W	under development	under development					
60W	under development	under development					

: Planar transformer

Construction of Planar Type Transformer

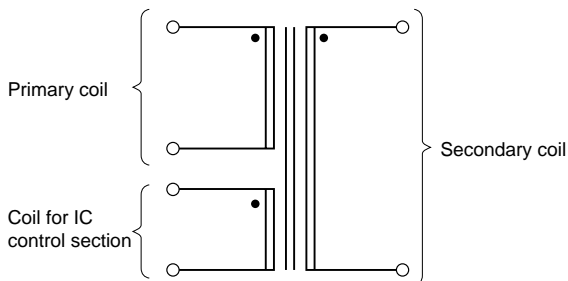

Example of Planar Type Transformer Design Specifications

- Circuit Forward type
- Switching frequency 300 kHz
- Input 48VDC
- Output 5VDC/8A

Shapes and Dimensions

SMD Transformer

Shapes of Bobbins

- FEY9.1/7.3

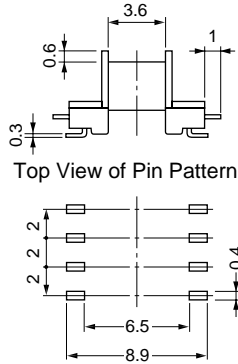
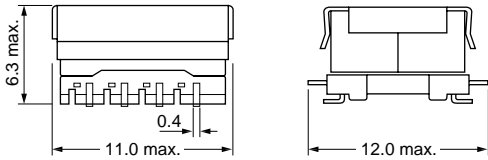

- FEY12.8/11.5

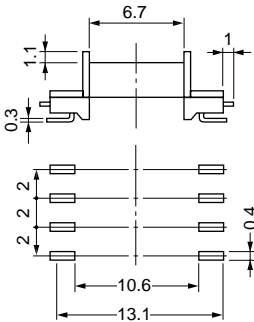
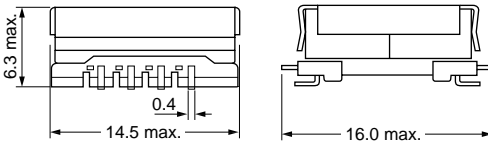

- FEY15.3/13.0

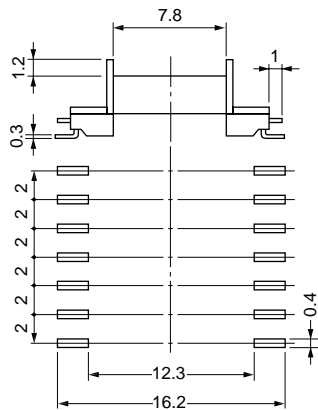
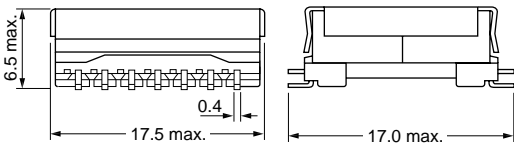

(mm)

Core constant

AL(BH1)	nH	1050 ± 30%
---------	----	------------

Core constant	$\Sigma l_e/A_e$	cm ⁻¹	19.06
Effective cross-sectional area	Ae	cm ²	0.088
Effective magnetic path length	l _e	cm	1.670
Effective volume	V _e	cm ³	0.146

AL(BH1)	nH	900 ± 30%
---------	----	-----------

Core constant	$\Sigma l_e/A_e$	cm ⁻¹	22.29
Effective cross-sectional area	Ae	cm ²	0.114
Effective magnetic path length	l _e	cm	2.536
Effective volume	V _e	cm ³	0.289

AL(BH1)	nH	950 ± 30%
---------	----	-----------

Core constant	$\Sigma l_e/A_e$	cm ⁻¹	21.53
Effective cross-sectional area	Ae	cm ²	0.136
Effective magnetic path length	l _e	cm	2.933
Effective volume	V _e	cm ³	0.399

Shapes of Bobbins

Core constant

● FED11.6

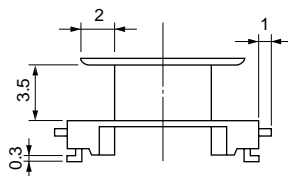
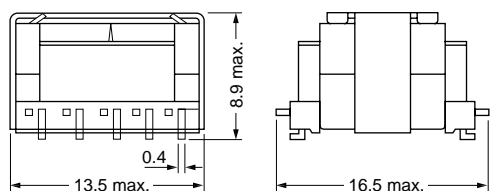

Top View of Pin Pattern

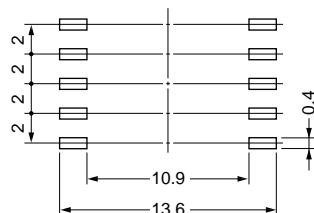

AL(BH1)	nH	2100 ± 30%
AL(1200IH)	nH	9700 ± 35%

Core constant	$\Sigma l_e/A_e$	cm ⁻¹	9.18
Effective cross-sectional area	Ae	cm ²	0.196
Effective magnetic path length	le	cm	1.800
Effective volume	Ve	cm ³	0.353

● FEP7T

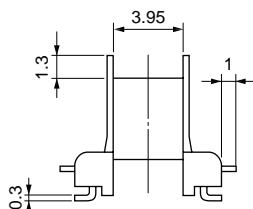
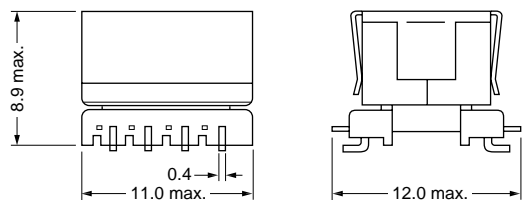

Top View of Pin Pattern

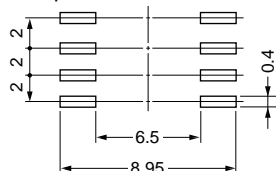

AL(1200IH)	nH	5000 ± 35%
------------	----	------------

Core constant	$\Sigma l_e/A_e$	cm ⁻¹	16.67
Effective cross-sectional area	Ae	cm ²	0.090
Effective magnetic path length	le	cm	1.500
Effective volume	Ve	cm ³	0.135

● FEE5

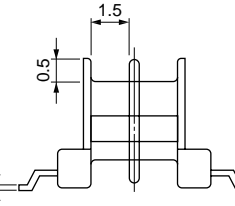
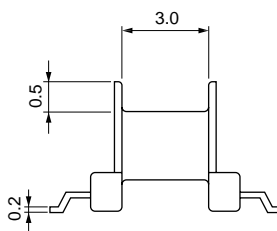
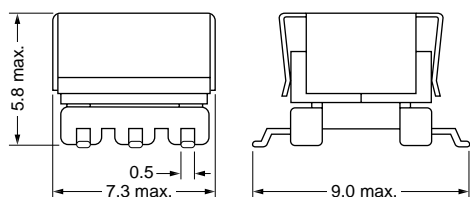

Top View of Pin Pattern

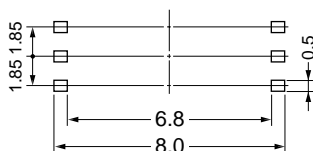

AL(BH1)	nH	370 ± 30%
AL(1200IH)	nH	1400 ± 35%

Core constant	$\Sigma l_e/A_e$	cm ⁻¹	47.76
Effective cross-sectional area	Ae	cm ²	0.026
Effective magnetic path length	le	cm	1.259
Effective volume	Ve	cm ³	0.033

(mm)