

Model 633

Very Low Jitter LVPECL or LVDS Clock

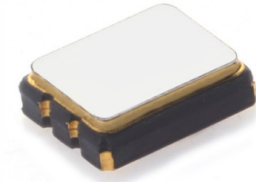

Part Dimensions:
3.2 × 2.5 × 1.0mm • 25.00mg

Features

- Ceramic Surface Mount Package
- Very Low Phase Jitter Performance, 500fs Maximum
- Fundamental or 3rd Overtone Crystal Design
- Frequency Range 10 – 220MHz *
- +2.5V or +3.3V Operation [+1.8V LVDS only]
- Output Enable Standard
- Tape and Reel Packaging, EIA-481

Standard Frequencies

* See Page 9 for common frequencies.
Check with factory for availability of frequencies not listed.

Applications

- SerDes
- Storage Area Networking
- Broadband Access
- SONET/SDH/DWDM
- PON
- Ethernet/Gbe/SyncE
- Fiber Channel
- Medical Electronics
- Test and Measurement

Description

CTS Model 633 is a low cost, high performance clock oscillator supporting differential LVPECL or LVDS outputs. Employing the latest IC technology, M633 has excellent stability and very low jitter/phase noise performance.

Ordering Information

Model	Output Type	Frequency Code [MHz]	Frequency Stability	Temperature Range	Supply Voltage	Packaging
633	P	XXX or XXXX	3	G	L	T
		Code Frequency Product Frequency Code ¹		Code Temp. Range A -10°C to +60°C C -20°C to +70°C I -40°C to +85°C G -40°C to +105°C ³	Code Voltage M +1.8Vdc ⁴ N +2.5Vdc L +3.3Vdc	Code Packing T 1k pcs./reel
	Code Output P LVPECL - Pin 1 Enable L LVDS - Pin 1 Enable E LVPECL - Pin 2 Enable V LVDS - Pin 2 Enable	Code Stability Code Stability 6 ±20ppm ² 4 ±30ppm 5 ±25ppm 3 ±50ppm		Code Stability Code Stability 6 ±20ppm ² 4 ±30ppm 5 ±25ppm 3 ±50ppm		

Notes:

- 1] Refer to document 016-1454-0, Frequency Code Tables. 3-digits for frequencies <100MHz, 4-digits for frequencies 100MHz or greater.
- 2] Check factory for availability. Temperature codes A and C only.
- 3] Check factory for availability. Stability codes 2 and 3 only.
- 4] LVDS output only. Consult factory for availability.

**Not all performance combinations and frequencies may be available.
Contact your local CTS Representative or CTS Customer Service for availability.**

This product is specified for use only in standard commercial applications. Supplier disclaims all express and implied warranties and liability in connection with any use of this product in any non-commercial applications or in any application that may expose the product to conditions that are outside of the tolerances provided in its specification.



Electrical Specifications

Operating Conditions

PARAMETER	SYMBOL	CONDITIONS	MIN	TYP	MAX	UNIT
Maximum Supply Voltage	V_{CC}	-	-0.5	-	4.0	V
Supply Voltage [Note 1]	V_{CC}	$\pm 5\%$	1.710 2.375 3.135	1.8 2.5 3.3	1.890 2.625 3.465	V
Supply Current						
LVPECL	I_{CC}	$V_{CC} = +2.5V$ or $+3.3V$ @ Maximum Load	-	55	88	mA
LVDS			-	45	66	
LVDS			-	7	20	
Operating Temperature	T_A	-	-20 -40 -40	+25	+70 +85 +105	$^{\circ}C$
Storage Temperature	T_{STG}	-	-40	-	+125	$^{\circ}C$

Frequency Stability

PARAMETER	SYMBOL	CONDITIONS	MIN	TYP	MAX	UNIT
Frequency Range						
LVPECL	f_0	$V_{CC} = +2.5V$ or $+3.3V$		10 - 220		MHz
LVDS				10 - 220		
LVDS			$V_{CC} = +1.8V$	20 - 220		
Frequency Stability [Note 2]	$\Delta f/f_0$	-		20, 25, 30, 50 or 100		\pm ppm
Aging	$\Delta f/f_{25}$	First Year @ $+25^{\circ}C$, nominal V_{CC}	-3	-	3	ppm

1.] LVDS output only for +1.8V option.

2.] Inclusive of initial tolerance at time of shipment, changes in supply voltage, load, temperature and 1st year aging.

Output Parameters

PARAMETER	SYMBOL	CONDITIONS	MIN	TYP	MAX	UNIT
Output Type	-	-		LVPECL		-
Output Load	R_L	Terminated to $V_{CC} - 2.0V$	-	50	-	Ohms
Output Voltage Levels	V_{OH}	PECL Load, $-20^{\circ}C$ to $+70^{\circ}C$	$V_{CC} - 1.025$	-	$V_{CC} - 0.880$	V
	V_{OL}		$V_{CC} - 1.810$	-	$V_{CC} - 1.620$	
	V_{OH}	PECL Load, $-40^{\circ}C$ to $+85^{\circ}C$	$V_{CC} - 1.085$	-	$V_{CC} - 0.880$	V
	V_{OL}		$V_{CC} - 1.830$	-	$V_{CC} - 1.555$	
Output Duty Cycle	SYM	@ $V_{CC} - 1.3V$	45	-	55	%
Rise and Fall Time	T_R, T_F	@ 20%/80% Levels, $R_L = 50$ Ohms	-	0.3	0.7	ns
LVDS						
Output Type	-	-		LVDS		-
Output Load	R_L	Between Outputs	-	100	-	Ohms
Output Voltage Levels	V_{OH}	LVDS Load	-	1.43	1.60	V
	V_{OL}		0.90	1.10	-	
Output Duty Cycle	SYM	@ 1.25V	45	-	55	%
Differential Output Voltage	V_{OD}	$R_L = 100$ Ohms	247	330	454	mV
Offset Voltage	V_{OS}	LVDS Load	1.125	1.25	1.375	V
Rise and Fall Time	T_R, T_F	@ 20%/80% Levels, $R_L = 100$ Ohms	-	0.4	0.7	ns

Electrical Specifications

Performance Data

Phase Noise [typical]

25MHz, LVPECL, $V_{CC} = 3.3V$, $T_A = +25^\circ C$

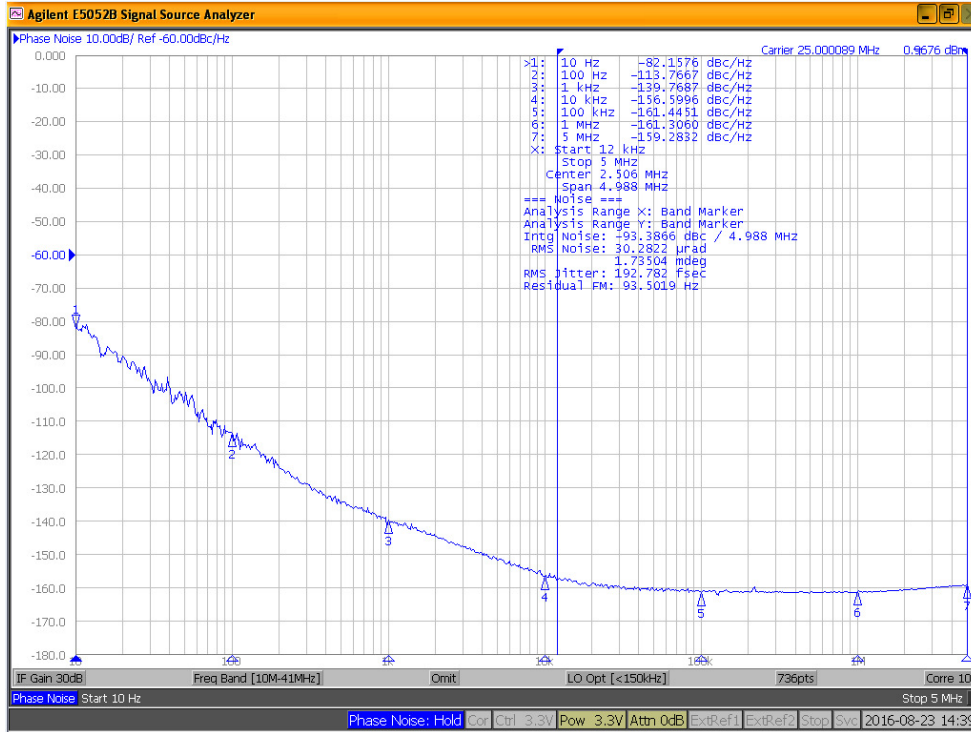

100MHz, LVPECL, $V_{CC} = 3.3V$, $T_A = +25^\circ C$

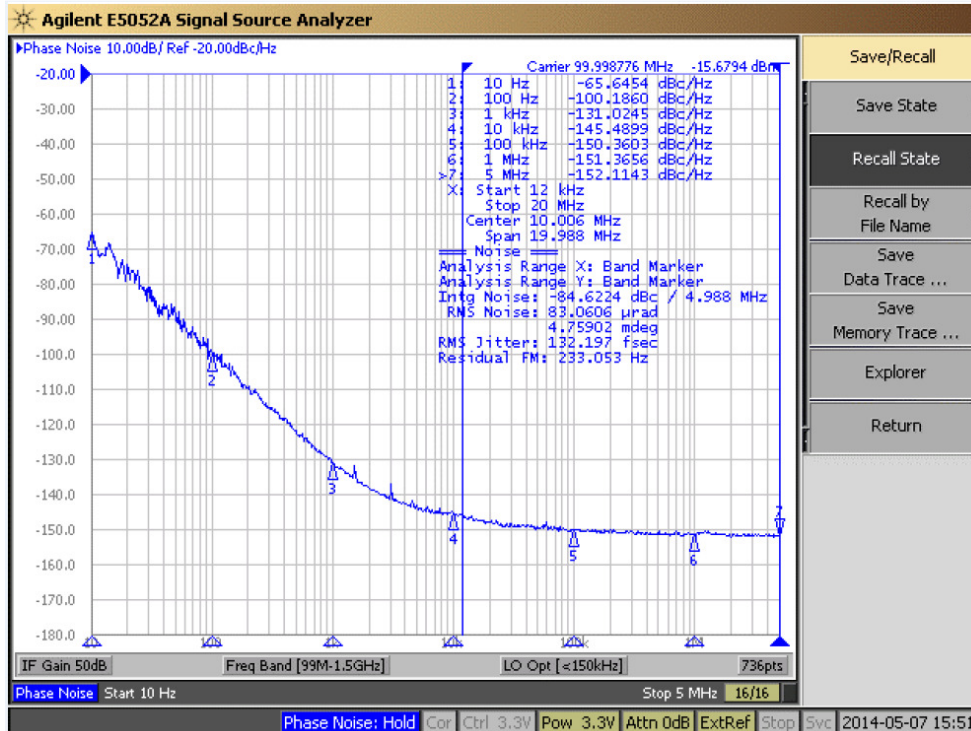

Electrical Specifications

Performance Data

Phase Noise [typical]

312.50MHz, LVPECL, $V_{CC} = 3.3V$, $T_A = +25^\circ C$

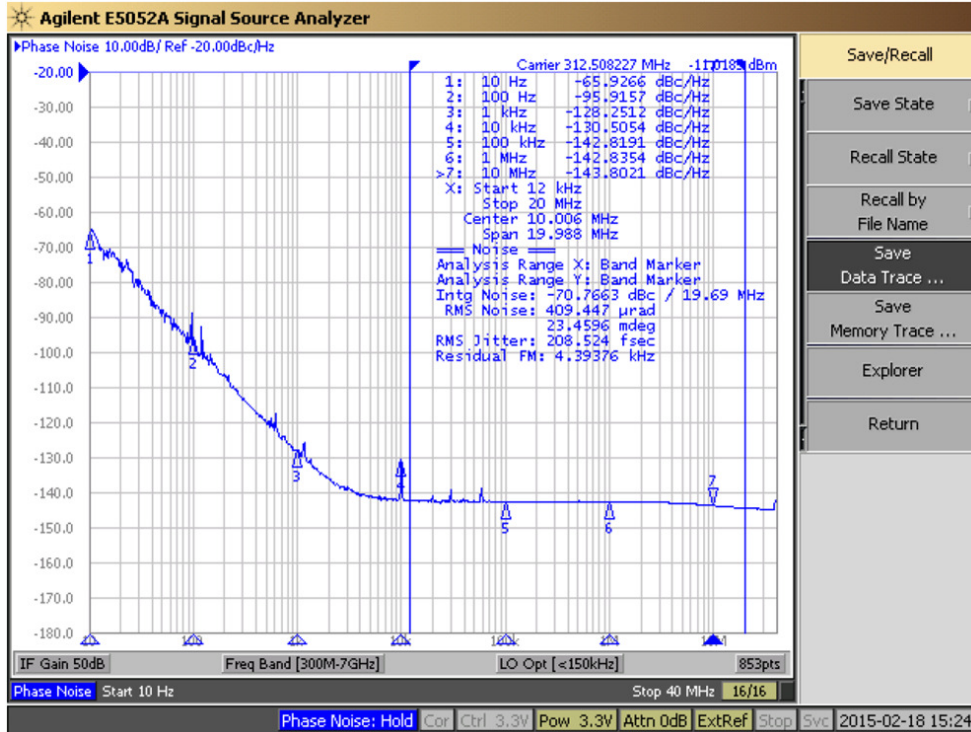

155.52MHz, LVDS, $V_{CC} = 3.3V$, $T_A = +25^\circ C$

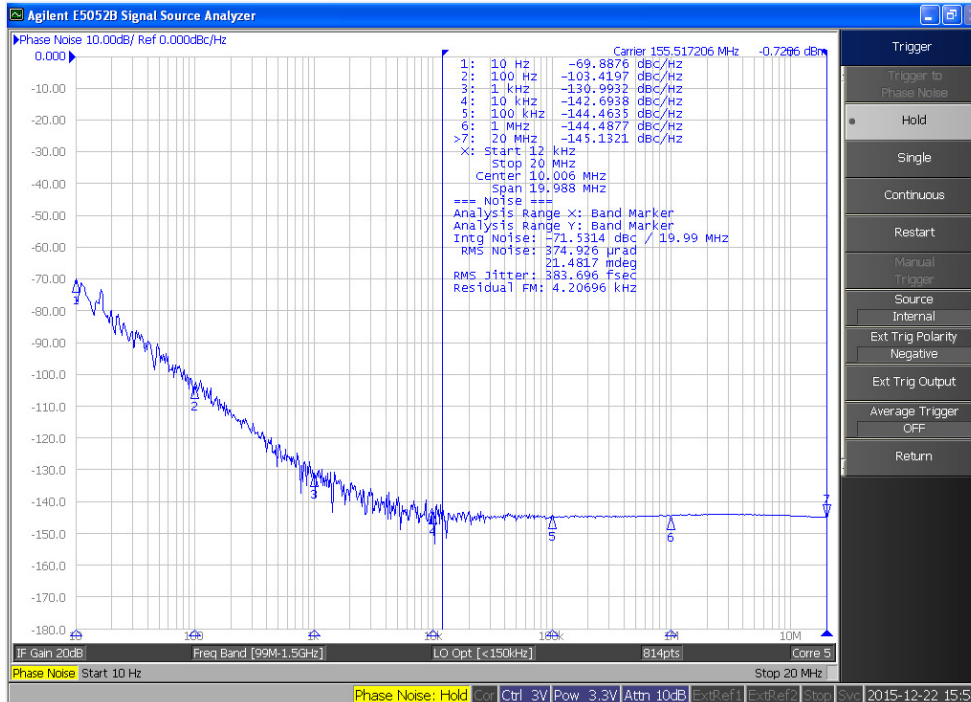



Electrical Specifications

Phase Noise Tabulated

Typical, $V_{CC} = 3.3V$, $T_A = +25^{\circ}C$

PARAMETER	SYMBOL	CONDITIONS	TYP	UNIT
LVPECL @ 25.00MHz				
Phase Noise		Single Side Band		
		@ 10Hz	-82.16	
		@ 100Hz	-113.77	
		@ 1kHz	-139.77	
	-	@ 10kHz	-156.60	dBc/Hz
		@ 100kHz	-161.45	
		@ 1MHz	-161.31	
	@ 5MHz	-159.28		
Phase Jitter, RMS	tjrms	Integration Bandwidth 12kHz - 20MHz	192.78	fs

PARAMETER	SYMBOL	CONDITIONS	TYP	UNIT
LVPECL @ 312.20MHz				
Phase Noise		Single Side Band		
		@ 10Hz	-65.93	
		@ 100Hz	-95.92	
		@ 1kHz	-128.25	
	-	@ 10kHz	-130.51	dBc/Hz
		@ 100kHz	-142.82	
		@ 1MHz	-142.84	
	@ 10MHz	-143.80		
Phase Jitter, RMS	tjrms	Integration Bandwidth 12kHz - 20MHz	208.52	fs

PARAMETER	SYMBOL	CONDITIONS	TYP	UNIT
LVPECL @ 100.00MHz				
Phase Noise		Single Side Band		
		@ 10Hz	-65.65	
		@ 100Hz	-100.19	
		@ 1kHz	-131.02	
	-	@ 10kHz	-145.49	dBc/Hz
		@ 100kHz	-150.36	
		@ 1MHz	-151.37	
	@ 5MHz	-152.11		
Phase Jitter, RMS	tjrms	Integration Bandwidth 12kHz - 20MHz	132.20	fs

PARAMETER	SYMBOL	CONDITIONS	TYP	UNIT
LVDS @ 155.52MHz				
Phase Noise		Single Side Band		
		@ 10Hz	-69.89	
		@ 100Hz	-103.42	
		@ 1kHz	-130.99	
	-	@ 10kHz	-142.69	dBc/Hz
		@ 100kHz	-144.46	
		@ 1MHz	-144.49	
	@ 20MHz	-145.13		
Phase Jitter, RMS	tjrms	Integration Bandwidth 12kHz - 20MHz	383.70	fs

Mechanical Specifications

Package Drawing

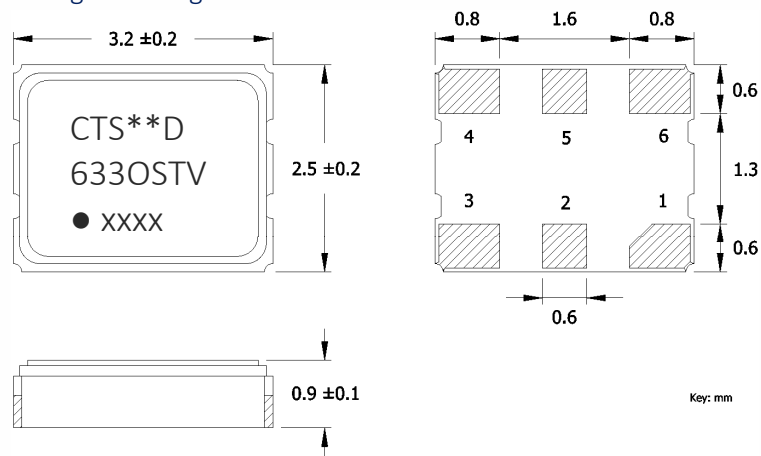

Recommended Pad Layout

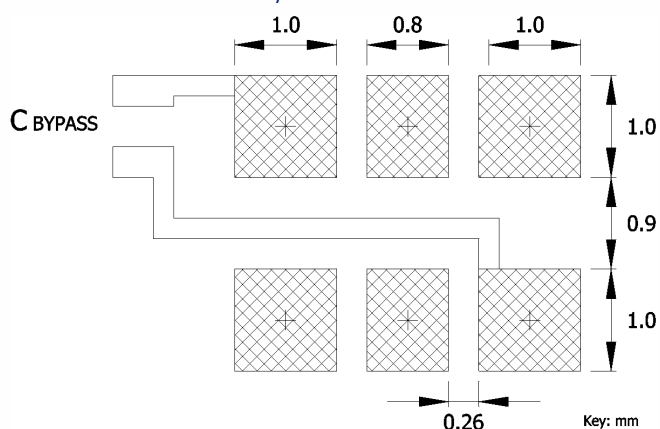

Pin Assignments

Pin	Symbol	Function
1	EOH or N.C.	Enable [std] or No Connect
2	N.C. or EOH	No Connect or Enable [opt]
3	GND	Circuit & Package Ground
4	Output	RF Output
5	Output	Complimentary RF Output
6	V _{CC}	Supply Voltage

Marking Information

Option 1 [3 lines, 7 characters maximum per line]

- ** - Manufacturing Site Code.
- D - Date Code. See Table I for codes.
- O - Output Type; P or E = LVPECL, L or V = LVDS.
- ST - Frequency Stability/Temperature Code. [Refer to Ordering Information]
- V - Voltage Code; 3 = 3.3V, 2 = 2.5V.
- xxxx - Frequency Code.

3-digits, frequencies below 100MHz
4-digits, frequencies 100MHz or greater

[See document 016-1454-0, Frequency Code Tables.]



Option 2 [2 lines, 7 characters maximum per line]

- O - Output Type; P or E = LVPECL, L or V = LVDS.
- ST - Frequency Stability/Temperature Code. [Refer to Ordering Information]
- V - Voltage Code; 3 = 3.3V, 2 = 2.5V.
- xxxx - Frequency Code.

3-digits, frequencies below 100MHz
4-digits, frequencies 100MHz or greater

[See document 016-1454-0, Frequency Code Tables.]

- D - Date Code. See Table I for codes.

[Note: Manufacturing site code must appear on reel and carton labels.]



- JEDEC termination code (e4). Barrier-plating is nickel [Ni] with gold [Au] flash plate.
- Reflow conditions per JEDEC J-STD-020; +260°C maximum, 20 seconds.
- MSL = 1.

Table I - Date Code, Beginning year 2021

YEAR					MONTH											
					JAN	FEB	MAR	APR	MAY	JUN	JUL	AUG	SEP	OCT	NOV	DEC
2021	2025	2029	2033	2037	A	B	C	D	E	F	G	H	J	K	L	M
2022	2026	2030	2034	2038	N	P	Q	R	S	T	U	V	W	X	Y	Z
2023	2027	2031	2035	2039	a	b	c	d	e	f	g	h	j	k	l	m
2024	2028	2032	2036	2040	n	p	q	r	s	t	u	v	w	x	y	z

Packaging - Tape and Reel

Tape Drawing

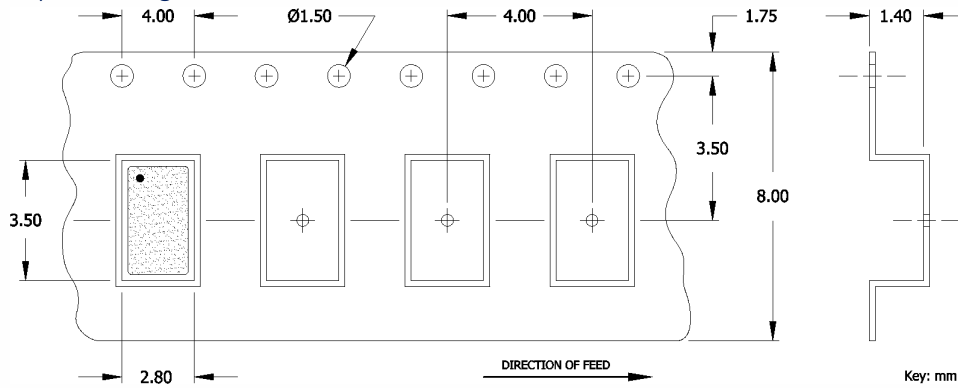

Reel Drawing

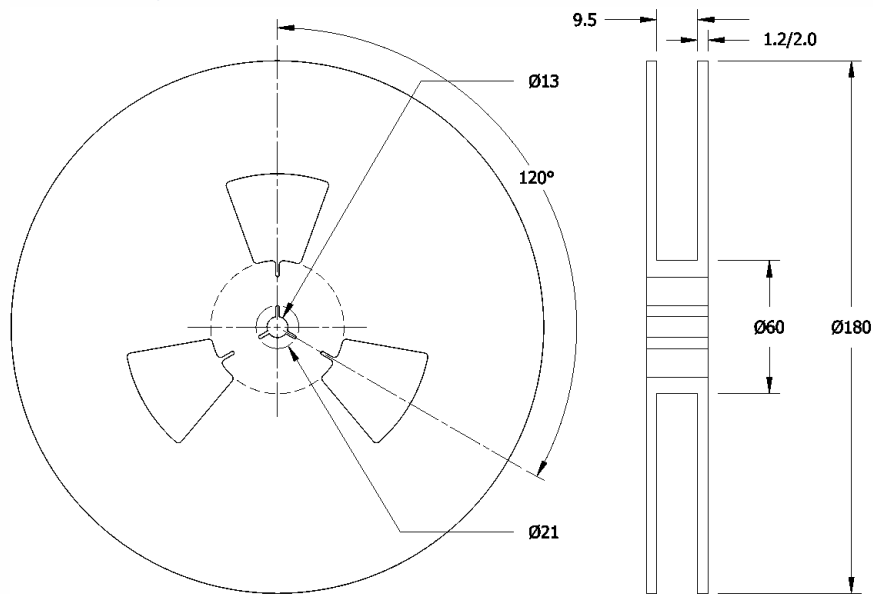

Notes

1. Device quantity is 1k pieces minimum or 3k pieces maximum per 180mm reel.
2. Complete CTS part number, frequency value and date code information must appear on reel and carton labels.



Addendum

Common Frequencies Available – MHz

FREQUENCY	FREQUENCY CODE	FREQUENCY	FREQUENCY CODE	FREQUENCY	FREQUENCY CODE	FREQUENCY	FREQUENCY CODE
10.000000	100	80.000000	800	156.250000	1562	200.000000	2000
19.440000	194	100.000000	1000	156.253906	156A	212.500000	2125
25.000000	250	120.000000	1200	161.132800	1611		
27.000000	270	125.000000	1250	167.372800	167A		
40.000000	400	133.000000	1330	173.370800	1733		
44.736000	447	148.351600	148A	175.000000	1750		
50.000000	500	148.500000	1485	178.500000	1785		
74.175800	74A	150.000000	1500	180.000000	1800		
74.250000	742	153.600000	1536	184.320000	1843		
80.000000	800	155.520000	1555	187.500000	1875		