



M.S.KENNEDY CORP.

# 600V/150A THREE PHASE BRIDGE PEM WITH BRAKE

# 4853

4707 Dey Road Liverpool, N.Y. 13088

(315) 701-6751

**FEATURES:**

- Replaces MSK 4850
- Full Three Phase Bridge Configuration with SCR/IGBT Brake
- 600V Rated Voltage
- 150A Continuous Output Current
- Internal Zener Clamps on Gates
- Proprietary Encapsulation Provides Near Hermetic Performance
- HI-REL Screening Available (Modified 38534)
- Light Weight Domed ALSIC Baseplate
- Robust Mechanical Design for Hi-Rel Applications
- Ultra-Low Inductance Internal Layout
- Withstands 96 Hours HAST and Thermal Cycling (-55°C to +125°C)

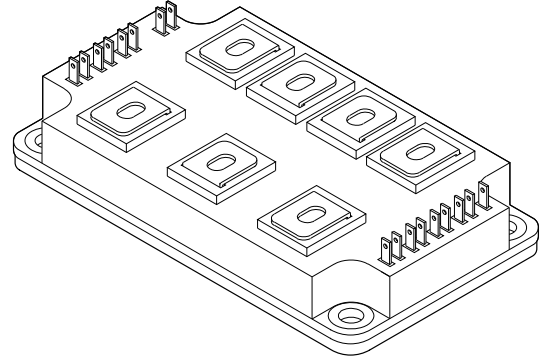

**DESCRIPTION:**

The MSK 4853 is one of a family of plastic encapsulated modules (PEM) developed specifically for use in military, aerospace and other severe environment applications. The Three Phase Bridge configuration along with the SCR/IGBT brake circuit and 600 volt/150 Amp rating make it ideal for use in high current motor drive and inverter applications. The Aluminum Silicon Carbide (AlSiC) baseplate offers superior flatness and light weight; far better than the copper or copper alloys found in most high power plastic modules. The high thermal conductivity materials used to construct the MSK 4853 allow high power outputs at elevated baseplate temperatures. Our proprietary coating, SEES™ - Severe Environment Encapsulation System - protects the internal circuitry of MSK PEM's from moisture and contamination, allowing them to pass the rugged environmental screening requirements of military and aerospace applications. MSK PEM's are also available with industry standard silicone gel coatings for a lower cost option.

**EQUIVALENT SCHEMATIC**

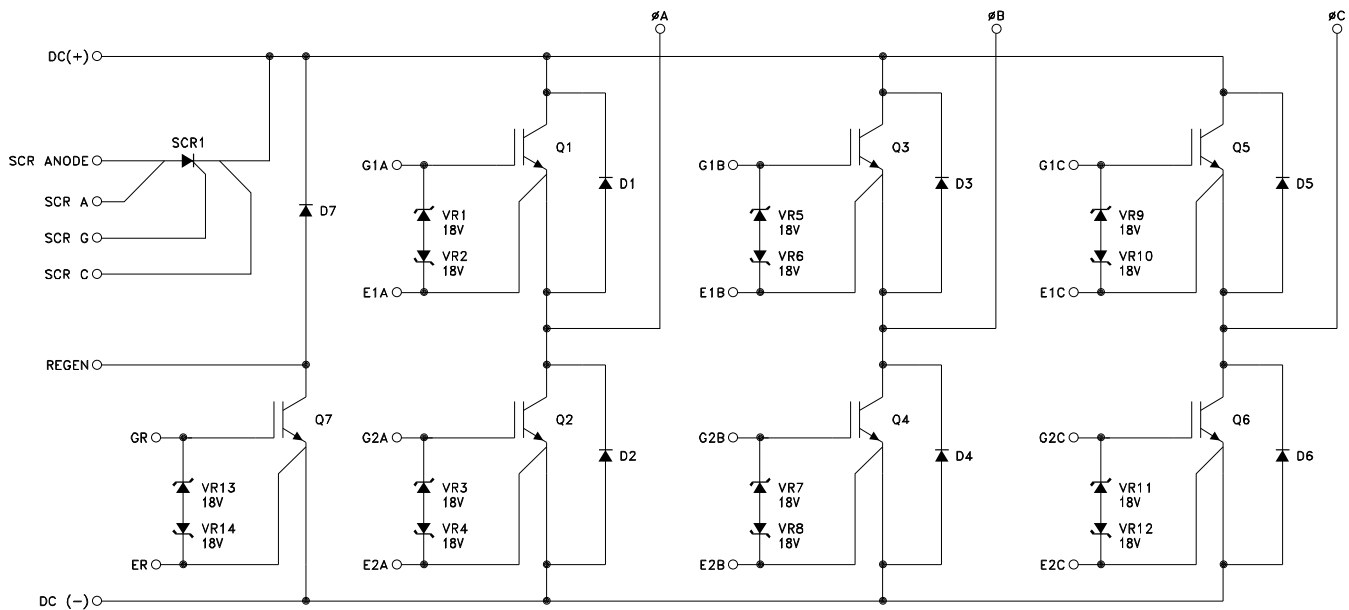

**TYPICAL APPLICATIONS**

- Motor Drives
- Inverters

# ABSOLUTE MAXIMUM RATING <sup>⑧</sup>

V<sub>CE</sub> Collector to Emitter Voltage . . . . . 600V  
 V<sub>GE</sub> Gate to Emitter Voltage . . . . . ± 20V  
 I<sub>OUT</sub> Current (Continuous) . . . . . 150A  
 I<sub>OUTP</sub> Current Pulsed (1mS) . . . . . 300A  
 V<sub>CASE</sub> Case Isolation Voltage . . . . . 2500 V

T<sub>ST</sub> Storage Temperature Range . . . -55°C to + 125°C  
 T<sub>J</sub> Junction Temperature . . . . . 150°C  
 T<sub>C</sub> Case Operating Temperature Range  
 MSK 4853H. . . . . -55°C to + 125°C  
 MSK 4853. . . . . -40°C to + 85°C

# ELECTRICAL SPECIFICATIONS

Parameter <sup>⑥</sup>	Test Conditions	Group A Subgroup	MSK 4853 H			MSK 4853			Units
			Min.	Typ.	Max.	Min.	Typ.	Max.	
Collector-Emitter Saturation Voltage	I <sub>C</sub> = 150A, V <sub>GE</sub> = 15V	1	-	TBD	1.9	-	TBD	2.0	V
		2	-	TBD	2.1	-	-	-	V
		3	-	TBD	2.6	-	-	-	V
Collector-Emitter Leakage Current	V <sub>CE</sub> = 600V, V <sub>GE</sub> = 0V	1	-	0.5	350	-	0.5	400	µA
		2	-	170	1700	-	-	-	µA
Gate Threshold Voltage	I <sub>C</sub> = 60mA, V <sub>CE</sub> = V <sub>GE</sub>	1	5.0	6.0	6.5	4.8	6.0	6.8	V
		2	4.0	5.0	6.5	-	-	-	V
		3	5.0	6.5	7.5	-	-	-	V
Gate Leakage Current	V <sub>CE</sub> = 0V, V <sub>GE</sub> = ± 15V	1	-	0.1	10	-	0.1	10	µA
		2	-	0.6	10	-	-	-	µA
		3	-	0.1	10	-	-	-	µA
Diode Forward Voltage	I <sub>C</sub> = 150A	1	-	TBD	1.9	-	TBD	2.1	V
		2	-	TBD	1.9	-	-	-	V
		3	-	TBD	2.8	-	-	-	V
SCR Reverse Leakage	V <sub>RRM</sub> = 600V	1	-	0.01	15	-	0.01	18	mA
		2	-	0.01	15	-	-	-	mA
		3	-	0.01	15	-	-	-	mA
SCR On Voltage	I <sub>F</sub> = 100A	1	-	1.0	1.35	-	1.0	1.4	V
		2	-	1.0	1.35	-	-	-	V
		3	-	1.0	1.35	-	-	-	V
SCR Holding Current		1	-	100	300	-	100	325	mA
		2	-	90	300	-	-	-	mA
		3	-	110	300	-	-	-	mA
Regen Diode Forward Voltage	I <sub>F</sub> = 50A	1	-	1.3	2.4	-	1.3	2.5	V
Total Gate Charge <sup>①</sup>	V = 300V, I <sub>C</sub> = 150A	4	-	1.0	1.5	-	1.0	1.6	µC
E <sub>(on)</sub> <sup>①</sup>	V = 300V, I <sub>C</sub> = 150A, R <sub>G</sub> = 5Ω, V <sub>GE</sub> = -7/+ 15V	4	-	6	-	-	6	-	mJ
	V = 300V, I <sub>C</sub> = 75A, R <sub>G</sub> = 5Ω, V <sub>GE</sub> = -7/+ 15V	4	-	3	6	-	3	7	mJ
	V = 300V, I <sub>C</sub> = 150A, R <sub>G</sub> = 5Ω, V <sub>GE</sub> = -7/+ 15V	5	-	7	-	-	-	-	mJ
	V = 300V, I <sub>C</sub> = 75A, R <sub>G</sub> = 5Ω, V <sub>GE</sub> = -7/+ 15V	5	-	4	-	-	-	-	mJ
E <sub>(off)</sub> <sup>①</sup>	V = 300V, I <sub>C</sub> = 150A, R <sub>G</sub> = 10Ω, V <sub>GE</sub> = -7/+ 15V	4	-	20	-	-	20	-	mJ
	V = 300V, I <sub>C</sub> = 75A, R <sub>G</sub> = 10Ω, V <sub>GE</sub> = -7/+ 15V	4	-	9	12	-	9	13	mJ
	V = 300V, I <sub>C</sub> = 150A, R <sub>G</sub> = 10Ω, V <sub>GE</sub> = -7/+ 15V	5	-	22	-	-	-	-	mJ
	V = 300V, I <sub>C</sub> = 75A, R <sub>G</sub> = 10Ω, V <sub>GE</sub> = -7/+ 15V	5	-	10	-	-	-	-	mJ
Diode Reverse Recovery Time <sup>①</sup>	I <sub>E</sub> = 150, di/dt = 3500A/µS	4	-	190	-	-	190	-	nS
	I <sub>E</sub> = 75, di/dt = 3500A/µS	4	-	185	-	-	185	-	nS
	I <sub>E</sub> = 150, di/dt = 3500A/µS	5	-	270	-	-	-	-	nS
	I <sub>E</sub> = 75, di/dt = 3500A/µS	5	-	250	-	-	-	-	nS
Diode Reverse Energy <sup>①</sup>	I <sub>E</sub> = 150, di/dt = 3500A/µS	4	-	2.5	-	-	2.5	-	mJ
	I <sub>E</sub> = 75, di/dt = 3500A/µS	4	-	2	4	-	2	-	mJ
	I <sub>E</sub> = 150, di/dt = 3500A/µS	5	-	5	-	-	-	-	mJ
	I <sub>E</sub> = 75, di/dt = 3500A/µS	5	-	8	-	-	-	-	mJ
Thermal Resistance <sup>①</sup>	IGBT @ T <sub>J</sub> = 125°C	-	-	0.22	0.26	-	0.22	0.26	°C/W
	DIODE @ T <sub>J</sub> = 125°C	-	-	0.35	0.41	-	0.35	0.41	°C/W

## NOTES:

- ① Guaranteed by design but not tested. Typical parameters are representative of actual device performance but are for reference only.
- ② Industrial grade devices shall be tested to subgroup 1 unless otherwise specified.
- ③ HI-REL grade devices ("H" suffix) shall be 100% tested to subgroups 1, 2 and sample tested to subgroup 3.
- ④ Subgroup 4 testing available upon request.
- ⑤ Subgroup 1, 4 T<sub>A</sub> = +25°C  
 2, 5 T<sub>A</sub> = +125°C  
 3 T<sub>A</sub> = -55°C
- ⑥ All specifications apply to both the upper and lower sections of the half bridge.
- ⑦ V<sub>GE</sub> = 15V unless otherwise specified.
- ⑧ Continuous operation at or above absolute maximum ratings may adversely effect the device performance and/or life cycle

***THERMAL CALCULATIONS***

Power dissipation and maximum allowable temperature rise involve many variables working together. Collector current, PWM duty cycle and switching frequency all factor into power dissipation. DC losses or "ON-TIME" losses are simply  $V_{CE(SAT)} \times I_C \times \text{PWM duty cycle}$ . For the MSK 4853,  $V_{CE(SAT)} = \text{TBD max.}$ , and at 150 amps and a PWM duty cycle of 30%, DC losses equal TBD watts. Switching losses, in milli-joules, vary proportionally with switching frequency. The MSK 4853 typical switching losses at  $V_{CE} = 300V$  and  $I_{CE} = 150A$  are about TBDmJ, which is simply the sum of the turn-on switching loss and the turn-off switching loss. Multiplying the switching frequency times the switching losses will result in a power dissipation number for switching. The MSK 4853, at 15KHz, will exhibit switching power dissipation of TBD watts. The total losses are the sum of DC losses plus switching losses, or in this case, TBD watts total. TBD watts x 0.26°C/W thermal resistance equals TBD degrees of temperature rise between the case and the junction. Subtracting TBD°C from the maximum junction temperature of 150°C equals TBD°C maximum case temperature for this example.

$$V_{CE(SAT)} \times I_C \times \text{PWM duty cycle} = \text{TBDV} \times 150 \text{ amps} \times 30\% = \text{TBD watts DC losses}$$

$$\text{Turn-on switching loss} + \text{Turn-off switching loss} = \text{Total switching losses} = \text{TBD} + \text{TBD} = \text{TBDmJ}$$

$$\text{Total switching loss} \times \text{PWM frequency} = \text{Total switching power dissipation} = \text{TBDmJ} \times 15\text{KHz} = \text{TBD watts}$$

$$\text{Total power dissipation} = \text{DC losses} + \text{switching losses} = \text{TBD} + \text{TBD} = \text{TBD watts}$$

$$\text{Junction temperature rise above case} = \text{Total power dissipation} \times \text{thermal resistance}$$

$$\text{TBD watts} \times \text{TBD}^\circ\text{C/W} = \text{TBD}^\circ\text{C temperature rise above case}$$

$$\text{Maximum junction temperature} - \text{junction temperature rise} = \text{maximum baseplate temperature}$$

$$150^\circ\text{C} - \text{TBD}^\circ\text{C} = \text{TBD}^\circ\text{C}$$

# TYPICAL PERFORMANCE CURVES

TYPICAL OUTPUT CHARACTERISTICS

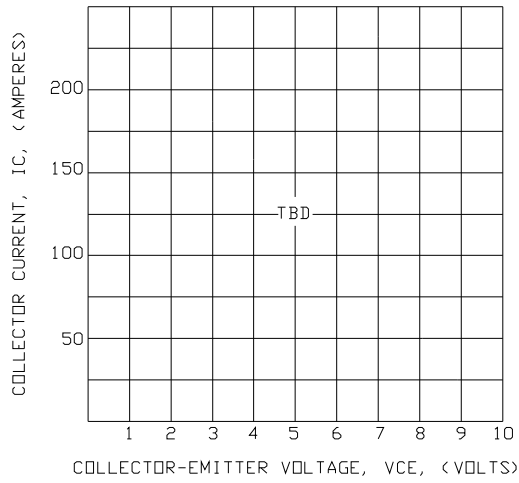

COLLECTOR-EMITTER SATURATION VOLTAGE CHARACTERISTICS

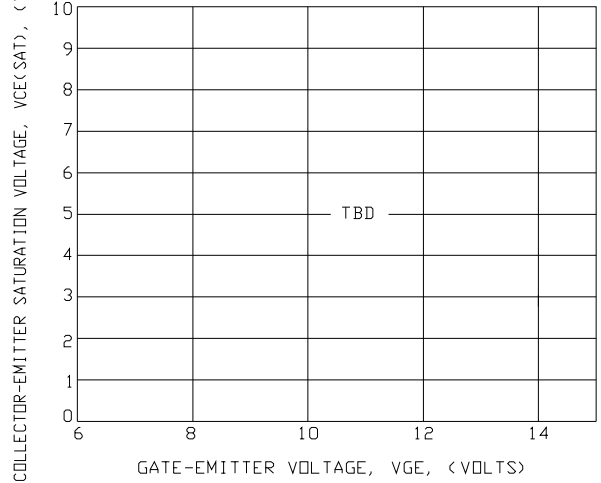

FREE-WHEEL DIODE FORWARD CHARACTERISTICS

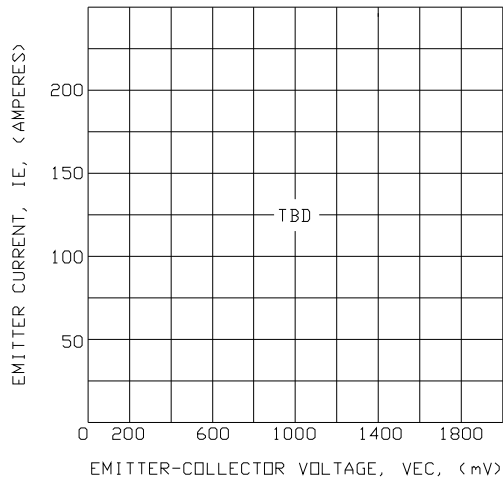

SWITCHING CHARACTERISTICS

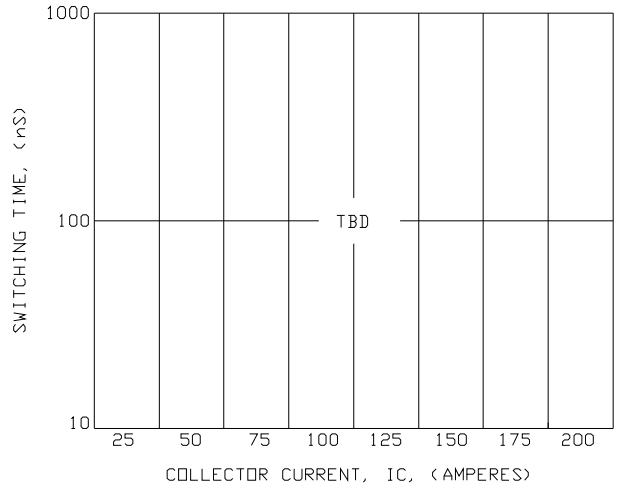

REVERSE RECOVERY CHARACTERISTICS

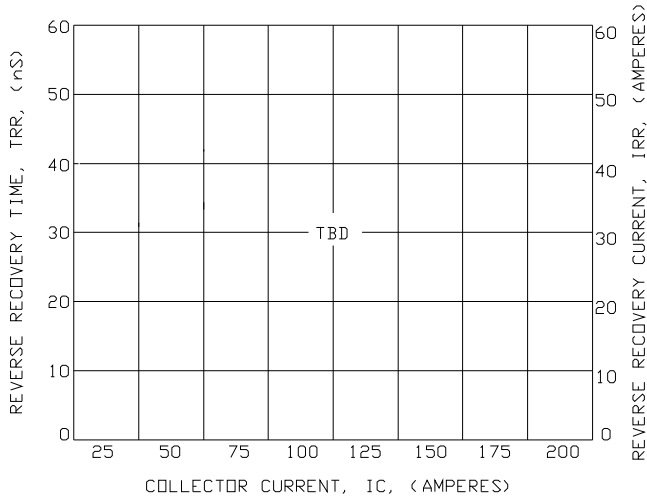

SWITCHING LOSS vs. COLLECTOR CURRENT

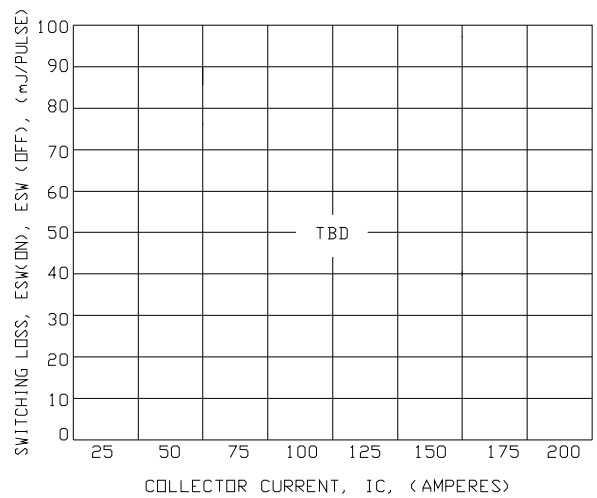

## SCREENING CHART

OPERATION	INDUSTRIAL	H SUFFIX
QUALIFICATION (MODIFIED)	NO	YES
ELEMENT EVALUATION	NO	YES
CLEAN ROOM PROCESSING	YES	YES
NON DESTRUCT BOND PULL SAMPLE	YES	YES
CERTIFIED OPERATORS	NO	YES
MIL LINE PROCESSING	YES	YES
MAX REWORK SPECIFIED	NO	YES
ENCAPSULANT	GEL COAT	SEES™
PRE-CAP VISUAL	YES - INDUSTRIAL	YES - CLASS H
TEMP CYCLE (-55°C TO +125°C)	NO	YES
BURN-IN	NO	YES - 160 HOURS
ELECTRICAL TESTING	YES - 25°C	YES - FULL TEMP
EXTERNAL VISUAL	YES - SAMPLE	YES
XRAY	NO	NO
PIN FINISH	NI	NI

NOTE: ADDITIONAL SCREENING IS AVAILABLE SUCH AS XRAY, CSAM, MECHANICAL SHOCK, ETC. CONTACT FACTORY FOR QUAL STATUS.

# MECHANICAL SPECIFICATIONS

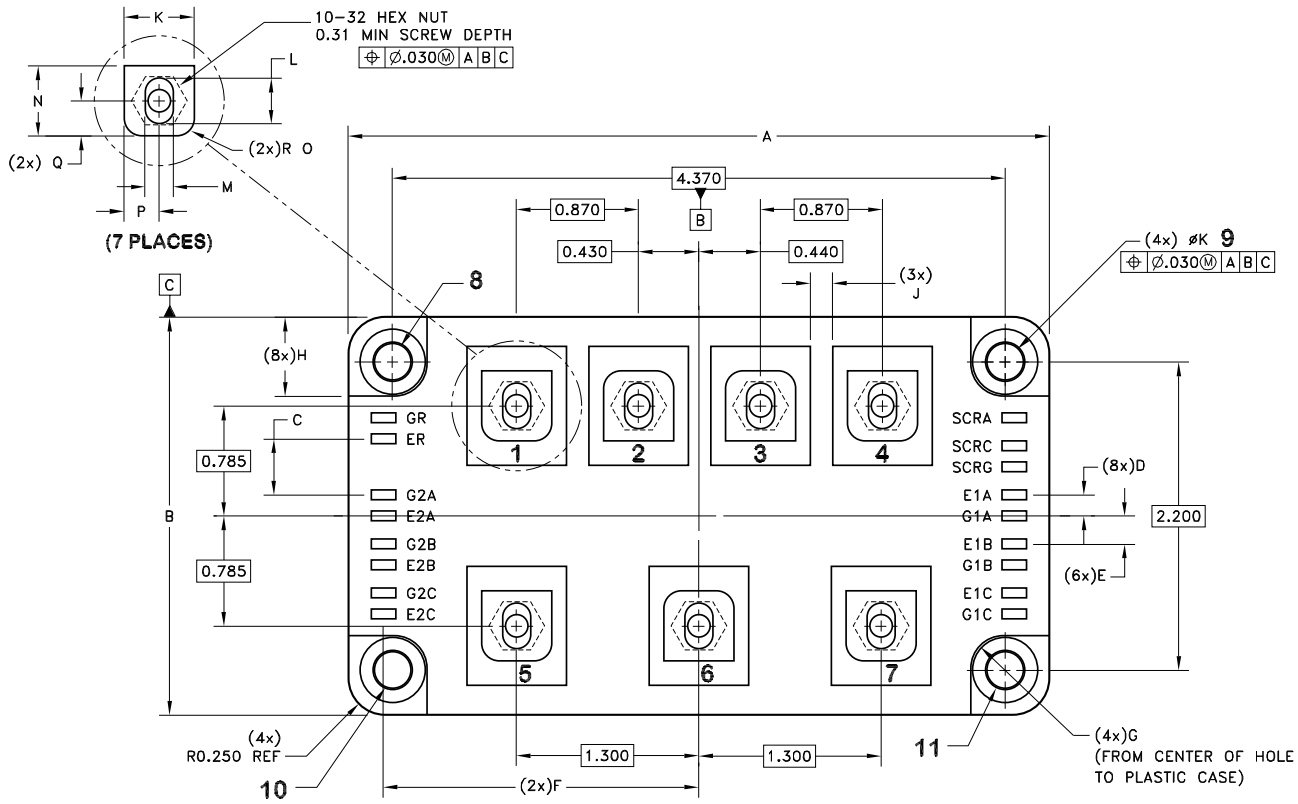

(4x)  $\varnothing$ K 9  
 $\oplus$  |  $\varnothing$ .030 | A | B | C

- SCRA
- SCRC
- SCRG
- E1A
- E1B
- G1A
- G1B
- E1C
- G1C

$\nabla$  0.008 CONVEX  
 0.000 CONCAVE

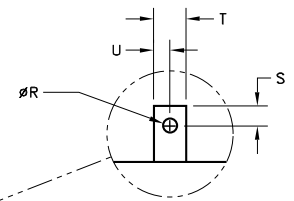

SCALE 2:1  
 (17 PLACES)

REF	MIN	MAX	REF	MIN	MAX
9	0.259	0.265	N	0.50	0.70
A	4.97	5.01	O	0.10	
B	2.81	2.85	P	0.20	0.30
C	0.39	0.41	Q		0.40
D	0.14	0.16	R	0.040	0.060
E	0.19	0.21	S	0.060	0.080
F	2.24	2.26	T	0.105	0.125
G	0.24		U	0.048	0.068
H	0.52		V	0.255	0.285
J	0.150		W	0.980	1.020
K	0.500	0.550	X	0.09	
L	0.310	0.340	WEIGHT		410g
M	0.195	0.230			

TRUE POSITION OF POWER TERMINAL  
 HEX NUTS & MOUNTING HOLE POSITIONS

REF	XDIM	YDIM
1	-1.300	0.785
9	2.185	1.100

WEIGHT = 410 GRAMS MAX.

FOR CONVEX BASEPLATE PROFILE SEE SHEET 7

# MECHANICAL SPECIFICATIONS

**POWER MODULE BOTTOM VIEW**  
(NOT TO SCALE)

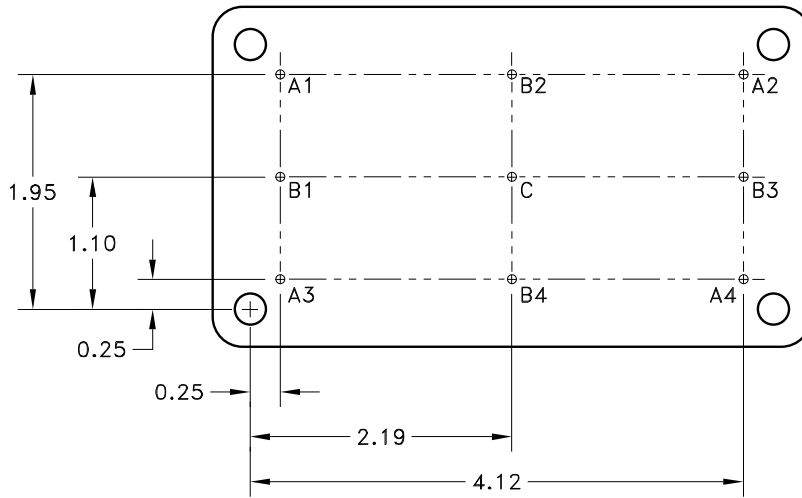

**POWER MODULE SIDE VIEW (EXAGGERATED DOME)**  
(NOT TO SCALE)

**CONVEX BASEPLATE PROFILE**

REF	ZMIN	ZMAX
A1	0.000	0.010
A2	0.000	0.010
A3	0.000	0.010
A4	0.000	0.010
B1	0.000	0.010
B2	0.000	0.010
B3	0.000	0.010
B4	0.000	0.010

NOTE:

1.(A1, A2, A3, B1, B2, B3 & B4) REFERENCED TO POINT C.

## ORDERING INFORMATION

MSK4853 H

**SCREENING**

BLANK = INDUSTRIAL

H = HI-REL (MODIFIED 38534)

**GENERAL PART NUMBER**

THE ABOVE EXAMPLE IS A MILITARY SCREENED MODULE.

**M.S. Kennedy Corp.**

4707 Dey Road Liverpool, New York 13088

Phone (315) 701-6751

FAX (315) 701-6752

www.mskennedy.com

The information contained herein is believed to be accurate at the time of printing. MSK reserves the right to make changes to its products or specifications without notice, however, and assumes no liability for the use of its products. Please visit our website for the most recent revision of this datasheet.