MSM5718C50/MD5764802

18Mb (2M × 9) & 64Mb (8M × 8) Concurrent RDRAM

DESCRIPTION

The 18/64-Megabit Concurrent Rambus™ DRAMs (RDRAM®) are extremely high-speed CMOS DRAMs organized as 2M or 8M words by 8 or 9 bits. They are capable of bursting unlimited lengths of data at 1.67 ns per byte (13.3 ns per eight bytes). The use of Rambus Signaling Level (RSL) technology permits 600 MHz transfer rates while using conventional system and board design methodologies. Low effective latency is attained by operating the two or four 2KB sense amplifiers as high speed caches, and by using random access mode (page mode) to facilitate large block transfers. Concurrent (simultaneous) bank operations permit high effective bandwidth using interleaved transactions.

RDRAMs are general purpose high-performance memory devices suitable for use in a broad range of applications including PC and consumer main memory, graphics, video, and any other application where high-performance at low cost is required.

FEATURES

- Compatible with Base RDRAMs
- 600 MB/s peak transfer rate per RDRAM
- Rambus Signaling Level (RSL) interface
- Synchronous, concurrent protocol for block-oriented, interleaved (overlapped) transfers
- 480 MB/s effective bandwidth for random 32 byte transfers from one RDRAM
- 13 active signals require just 32 total pins on the controller interface (including power)
- 3.3 V operation
- Additional/multiple Rambus Channels each provide an additional 600 MB/s bandwidth
- Two or four 2KByte sense amplifiers may be operated as caches for low latency access
- Random access mode enables any burst order at full bandwidth within a page
- Graphics features include write-per-bit and mask-per-bit operations
- Available in horizontal surface mount plastic package (SHP32-P-1125-0.65-K)

PART NUMBERS

The 18- and 64-Megabit RDRAMs are available in horizontal surface mount plastic package (SHP), with 533 and 600 MHz clock rate. The part numbers for the various options are shown in Table 1.

Table 1 Part Numbers by Option

Options	533 MHz	600 MHz
18-Megabit SHP	MSM5718C50-53GS-K	MSM5718C50-60GS-K
64-Megabit SHP	MD5764802-53MC	MD5764802-60MC

RDRAM PACKAGES AND PINOUTS

RDRAMs are available in horizontal surface mount plastic package (SHP).

The package has 32 signal pins and four mechanical pins that provide support for the device. The mechanical pins are located on the opposite side from the signal leads in the SHP.

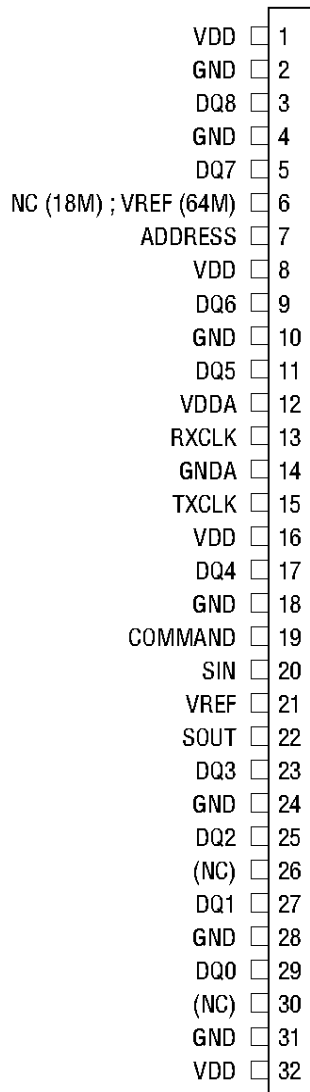

Fig. 1 SHP Pin Numbering

Table 2 Pin Descriptions

Signal	I/O	Description
DQ8..DQ0 (BUSDATA [8:0])	I/O	Signal lines for REQ, DIN, and DOUT packets. The REQ packet contains the address field, command field, and other control fields. These are RSL signals. ^a
CLK (RXCLK)	I	Receive clock. All input packets are aligned to this clock. This is an RSL signal. ^a
CLK (TXCLK)	I	Transmit clock. DOUT packets are aligned with this clock. This is an RSL signal. ^a
VREF	I	Logic threshold reference voltage for RSL signals.
COMMAND (BUSCTRL)	I	Signal line for REQ, RSTRB, RTERM,WSTRB, WTERM, RESET, and CKE packets. This is an RSL signal. ^a
ADDRESS (BUSENABLE)	I	Signal line for COL packets with column addresses. This is an RSL signal. ^a
VDD, VDDA	—	+3.3 V power supply. VDDA is a separate analog supply for clock generation in the RDRAM.
GND, GNDA	—	Circuit ground. GNDA is a separate analog ground for clock generation in the RDRAM.
SIN	I	Initialization daisy chain input. CMOS levels.
SOUT	O	Initialization daisy chain output. CMOS levels.

a. RSL stands for Rambus Signaling Levels, a low-voltage-swing, active-low signaling technology.

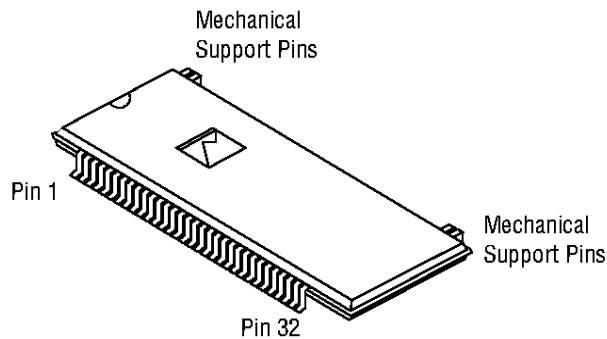

Fig. 2 SHP Package

GENERAL DESCRIPTION

Figure 3 is a block diagram of an RDRAM. At the bottom is a standard DRAM core organized as two or four independent banks, with each bank organized as 512 or 1024 rows, and with each row consisting of 2KBytes of memory cells. One row of a bank may be “activated” at any time (ACTV command) and placed in the 2KByte “page” for the bank. Column accesses (READ and WRITE commands) may be made to this active page.

The smallest block of memory that may be accessed with READ and WRITE commands is an octbyte (eight bytes). Bitmask and bytemask options are available with the WRITE command to allow finer write granularity. There are six control registers that are accessed at initialization time to configure the RDRAM for a particular application.

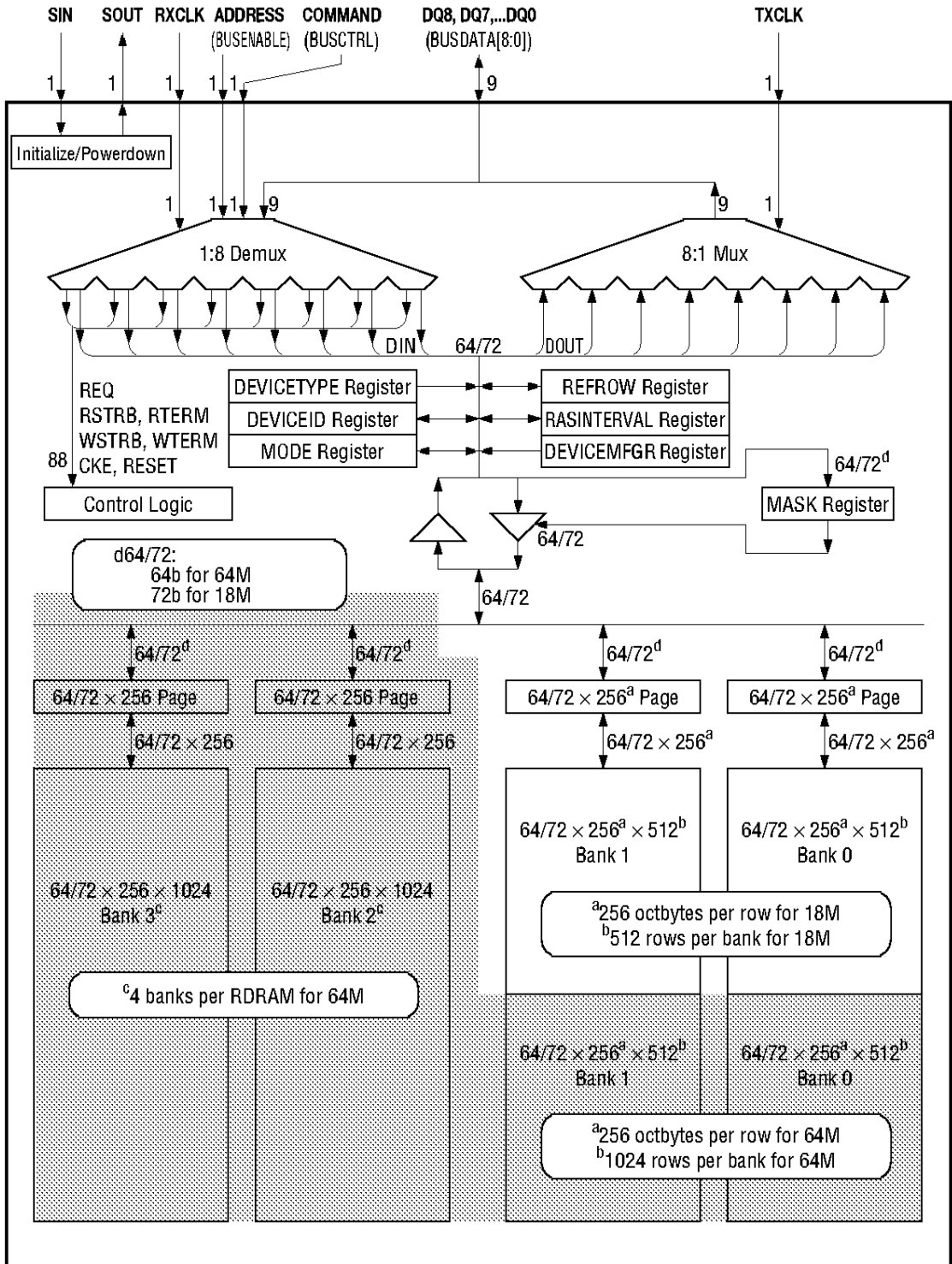
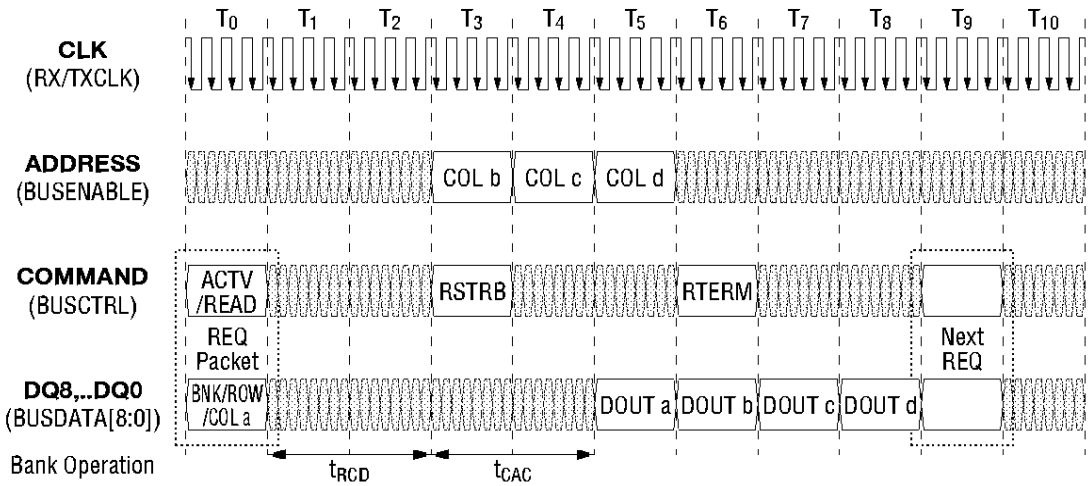

Fig. 3 18/64-Mbit Concurrent RDRAM Block Diagram

BASIC OPERATION

Figure 4 (a) shows an example of a read transaction. A transaction begins in interval T_0 with the transfer of a REQ packet. The REQ packet contains the command (ACTV/READ), a device, bank, and row address (BNK/ROW) of the page to be activated, and the column address (COLa) of the first octbyte to be read from the page.

The selected bank performs the activation of the selected row during T_1 and T_2 (the t_{RCD} interval). Next, the selected bank reads the selected octbyte during T_3 and T_4 (the t_{CAC} interval). A second command RSTRB (read strobe) is transferred during T_3 and causes the first octbyte (DOUTa) to be transferred during T_5 .



(a) BANK ACTIVATE AND RANDOM READ CYCLES WITHIN A PAGE

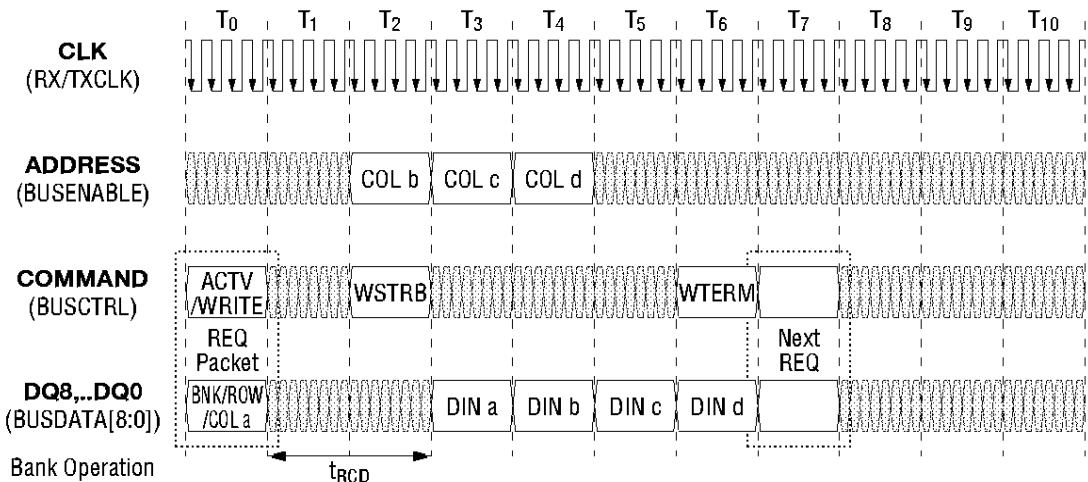

(b) BANK ACTIVATE AND RANDOM WRITE CYCLES WITHIN A PAGE

Fig. 4 Read and Write Transaction Examples

In this example, three additional octabytes are read from the activated page. These column addresses (COLb, COLc, and COLd) are transferred in T₃, T₄, and T₅, respectively. The data octabytes (DOUTb, DOUTc, and DOUTd) are transferred in T₆, T₇, and T₈. The end of the data octabytes is signaled by a third command RTERM (read terminate) in T₆. The next REQ packet may be sent in T₉, or in any interval thereafter.

Figure 4 (b) shows an example of a write transaction. The transaction begins in interval T₀ with the transfer of a REQ packet. The REQ packet contains, the command (ACTV/WRITE), a device, bank, and row address (BNK/ROW) of the page to be activated, and the column address (COLa) of the first octbyte to be written to the page.

The selected bank performs the activation of the selected row during T₁ and T₂ (the t_{RCD} interval). A second command WSTRB (write strobe) is transferred during T₂ and causes the first octbyte (DINa) to be transferred during T₃.

In this example, three additional octabytes are written to the activated page. These column addresses (COLb, COLc, and COLd) are transferred in T₂, T₃, and T₄ respectively. The data octabytes (DINb, DINc, and DINd) are transferred in T₄, T₅, and T₆. The end of the data octabytes is signaled by a third command WTERM (write termination) in T₆. The next REQ packet may be sent in T₇, or in any interval thereafter.

INTERLEAVED TRANSACTIONS

The previous examples showed noninterleaved transactions - the next REQ packet was transferred after the last data octbyte of the current transaction. In an interleaved transaction, the next REQ packet is transferred before the first data octbyte of the current transaction. This permits the row and column access intervals of the next transaction to overlap the data transfer of the current transaction.

Figure 5 shows an example of interleaved read transactions. The first transaction proceeds exactly as the noninterleaved example of Figure 4 (a) (all packets of the first transaction are labeled with "1"). However, in T₅ the REQ packet for the second transaction is transferred (all packets of the second transaction are labeled with "2"). The t_{RCD2} and t_{CAC2} intervals overlap the transfer of DOUT1 data octbytes and thus increase the effective bandwidth of the RDRAM since there are no unused intervals.

A transaction consists of an address transfer phase and a data transfer phase. The REQ packet performs address transfer, and the remaining packets perform data transfer (DOUT, COL, RSTRB, and RTERM in the case of a read transaction). The time interval between the address and data transfer phases of the current transaction may be adjusted to match the data length of the previous transaction (as long as the row and column access times for the current transaction are observed). Thus, there are no limits on the types of memory transaction which may be interleaved; any mixing of transaction length and command type is permitted.

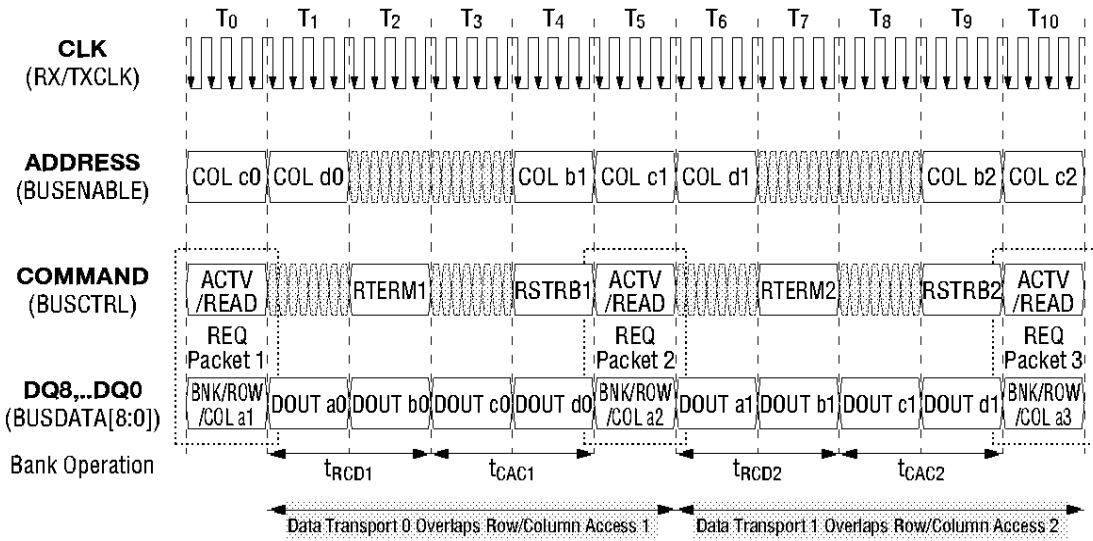

Fig. 5 Interleaved Read Transaction Example

REQ PACKET (ADDRESS TRANSFER)

An REQ packet initiates a transaction by transferring the address and command information to the RDRAM. Figure 6 shows the format of the REQ packet. Note that each RDRAM wire carries eight bits of information in each t_{PACKET} . This is the time required to transfer an octbyte of data and is the natural granularity with which to illustrate timing relationships. The clock that is actually used by the RDRAM has a period of t_{CYCLE} , with information transferred on each clock edge. t_{PACKET} is four times t_{CYCLE} .

In the REQ packet, the bits which are gray are reserved, and should be driven with a zero. In particular, the bits in $t_{\text{CYCLE}} t_6$ and t_7 are needed for bus-turn-around during read transactions.

A35..A3: The address field A35..A3 consumes the greatest number of bits. These are allocated to device, bank, row, and column addressing according to Table 3:

Table 3 A35..A3 Address Fields

Field	18M	64M
COL	A10..A3	A10..A3
ROW	A19..A11	A20..A11
BNK	A20	A22, A21
DEV	A35..A21	A35..A23

OP5..OP0: The command field OP5..OP0 specifies the type of transaction that is to be performed, according to Table 4. The OP0 bit selects a read or write transaction, the OP1 bit selects a memory or register space access, and OP5..OP2 select command options. These command options include B in OP2 (see byte masking on page 22). D in OP3 for selecting broadcast operations (see refresh on page 35), and b1, b0 in OP5, OP4 (see bit masking on page 23).

ACTV: This bit specifies activation or precharge/activation of a bank at the beginning of a transaction, and is designated by prepending "ACTV/" or "PRE/ACTV/" to the command.

AUTO: This bit specifies auto-precharge of a bank at the end of the transaction, and is designated by appending "A" to the command.

START: This bit is always set to a one and indicates the beginning of a request to the RDRAM.

REGSEL: This bit is used for accessing registers.

PEND2...PEND0: This field is set to "000" for noninterleaved transactions, and to a nonzero value for interleaved transactions. This is the number of previous STRB and TERM packets the RDRAM is to skip. Refer to the *Concurrent RDRAM Design Guide* for further details.

M7..M0: This field is used to perform byte masking of the first data octbyte DINa for all memory write transactions (OP1, OP0 = 01). Refer to byte masking on page 22.

Table 4 Command Encoding

ACTV	AUTO	OP5	OP4	OP3	OP2	OP1	OP0	Command	Description
0	0	0	0	0	X	0	0	READ	Read
0	0	b1	b0	D	B	0	1	WRITE	Write (b1, b0, B masking and D broadcast options)
0	0	0	0	0	1	1	0	RREG	Register Read
0	0	0	0	D	1	1	1	WREG	Register Write (D)
0	1	0	0	0	X	0	0	READA	Read/AutoPrecharge
0	1	b1	b0	D	B	0	1	WRITEA	Write/AutoPrecharge (b1, b0, D, B)
1	0	0	0	0	X	0	0	ACTV/READ	Activate/Read
1	0	b1	b0	D	B	0	1	ACTV/WRITE	Activate/Write (b1, b0, D, B)
1	1	0	0	0	X	0	0	ACTV/READA	Activate/Read/AutoPrecharge
1	1	b1	b0	D	B	0	1	ACTV/WRITEA	Activate/Write/AutoPrecharge (b1, b0, D, B)
1	0	0	0	0	X	0	0	PRE/ACTV/READ	Precharge/Activate/Read
1	0	b1	b0	D	B	0	1	PRE/ACTV/WRITE	Precharge/Activate/Write (b1, b0, D, B)
1	1	0	0	0	X	0	0	PRE/ACTV/READA	Precharge/Activate/Read/AutoPrecharge
1	1	b1	b0	D	B	0	1	PRE/ACTV/WRITEA	Precharge/Activate/Write/AutoPrecharge (b1, b0, D, B)

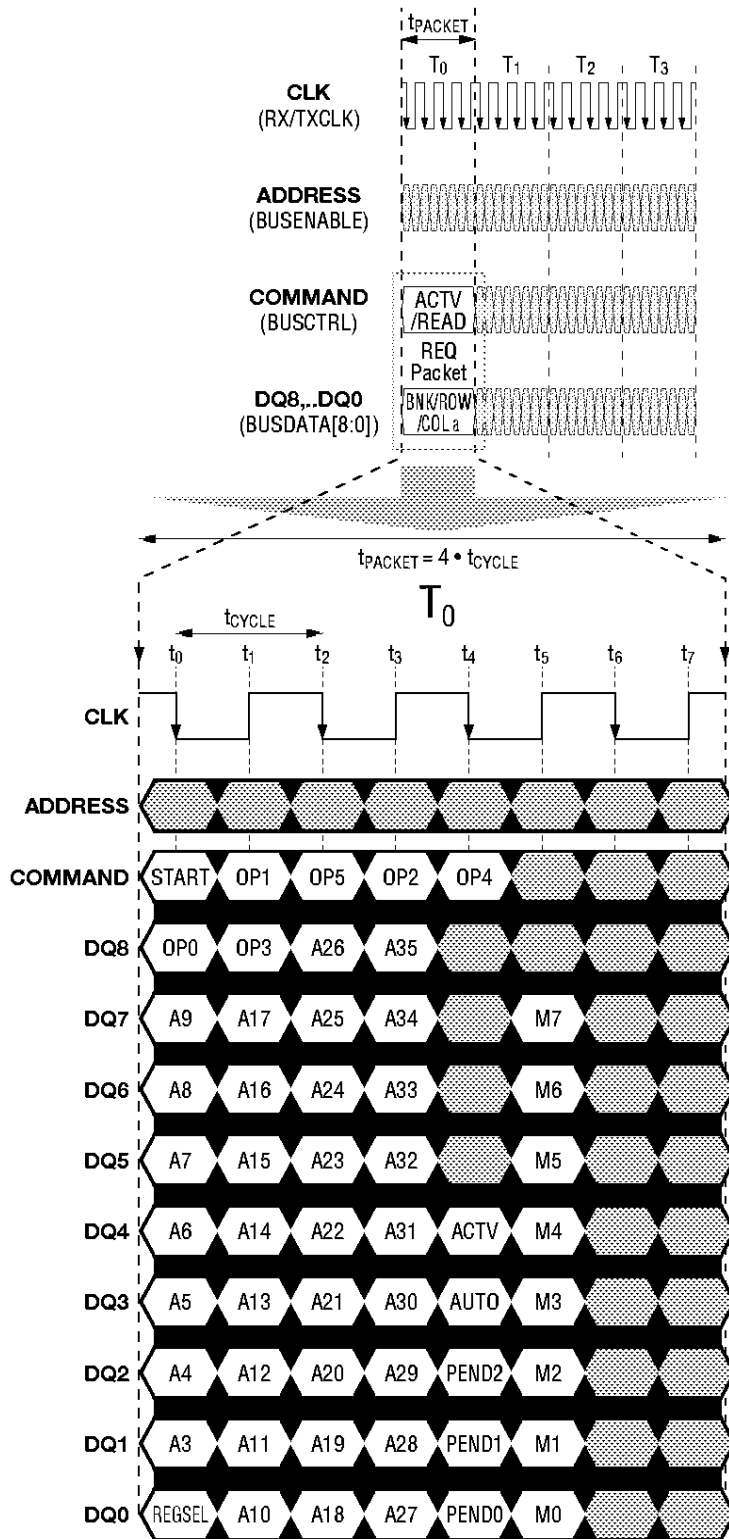

Fig. 6 REQ Packet Format

DATA TRANSFER PACKETS

The next set of packet types are used for data transfer. Their formats are summarized in Figure 7.

As in the REQ packet, eight bits are transferred on each wire during each t_{PACKET} interval. The rising and falling edges of the RDRAM clock define the transfer windows for each of these bits. The data transfer packets will align to the t_{PACKET} intervals defined by the START bit of the REQ packet by simply observing the timing rules that are developed in the next few sections of this document.

DIN and DOUT Packets

There are nine wires allocated for the data bytes. These wires are labeled DQ8..DQ0. The eight bytes transferred in a DIN or DOUT packet have 72 bits, which are labeled D0..D63 (on the DQ0..DQ7 wires) and E0..E7 (on the DQ8 wire). The 18Mbit RDRAM have storage cells for the E0..E7 bits. The E0..E7 bits are also used with byte masking operations. This is described in the section on byte masking on page 22.

COL Packet

The column address A10..A3 of the first octbyte of data (DINa or DOUTa) is provided in the REQ packet. The COL packet contains an eight bit field A10..A3, which provides the column address for the second and subsequent data octbytes. The COL packets have a fixed timing relationship with respect to the DIN and DOUT packets to which they correspond. As the DIN and DOUT packets are moved (to accommodate interleaving), the COL packets move with them.

RSTRB and RTERM Packets

The RSTRB and RTERM packets indicate the beginning and end of the DOUT packets that are transferred during a read transaction. The RSTRB and RTERM packets are each eight bits and consist of a single "1" in an odd t_{CYCLE} position, with the other seven positions "0". Note that when a transaction transfers a single data octbyte, the RSTRB and RTERM packets will overlay one another. This is permitted and is in fact the reason that each packet consists of a single asserted bit. An example of this case is shown in Figure 14 (a). There will be transaction situations in which the RTERM overlays a RSTRB packet (two octbyte interleaved transaction). Again, this is permitted. The general rule is that the RTERM may overlay any of the other packets on the Command (BUSCTRL) wire, and RSTRB may overlay any other except for a REQ packet.

WSTRB and WTERM Packets

TheWSTRB and WTERM packets indicate the beginning and end of the series of DIN packets that are transferred during a write transaction. TheWSTRB and WTERM packets are each eight bits and consist of a single "1" in an odd t_{CYCLE} position, with the other seven positions "0". Note that when a transaction transfers a single data octbyte, theWSTRB and WTERM packets will not overlay one another (unlike the case of a one octbyte read). An example of this case is shown in Figure 14 (b). There will be transaction situations in which theWSTRB overlays a REQ packet (no bank activate). Again, this is permitted. An example of this is shown in Figure 9 (a). The general rule is that theWSTRB may overlay any of the other packets on the Command (BUSCTRL) wire, and WTERM may overlay any other except for a REQ packet.

CKE PACKET

The average power of the RDRAM can be reduced by using Suspend power mode. This is done by setting the FR field of the MODE register to a zero (the MODE register is shown in Figure 17). A CKE packet must be sent a time t_{CKE} ahead of each REQ packet (this is shown in interval T_0 in Figure 21 (b)). This causes the RDRAM to transition from Suspend to Enable mode. When the RDRAM has finished the transaction, it returns to Suspend mode. The CKE packet will overlay the RSTRB and RTERM packets when transactions are interleaved. If the FR field is set to a one, CKE packets are not used and the RDRAM remains in Enable mode.

RESET PACKET

The RESET packet is used during initialization. When RESET packets are driven for a time t_{RESET} or greater, the RDRAM will assume a known state. Because the RESET packet is limited to this one use, it will not interact with the other packet types. This is illustrated in Figure 21 (a).

PWRUP PACKET

The PWRUP packet is used to cause an RDRAM to transition from Powerdown to Enable mode. This is illustrated in Figure 21 (c).

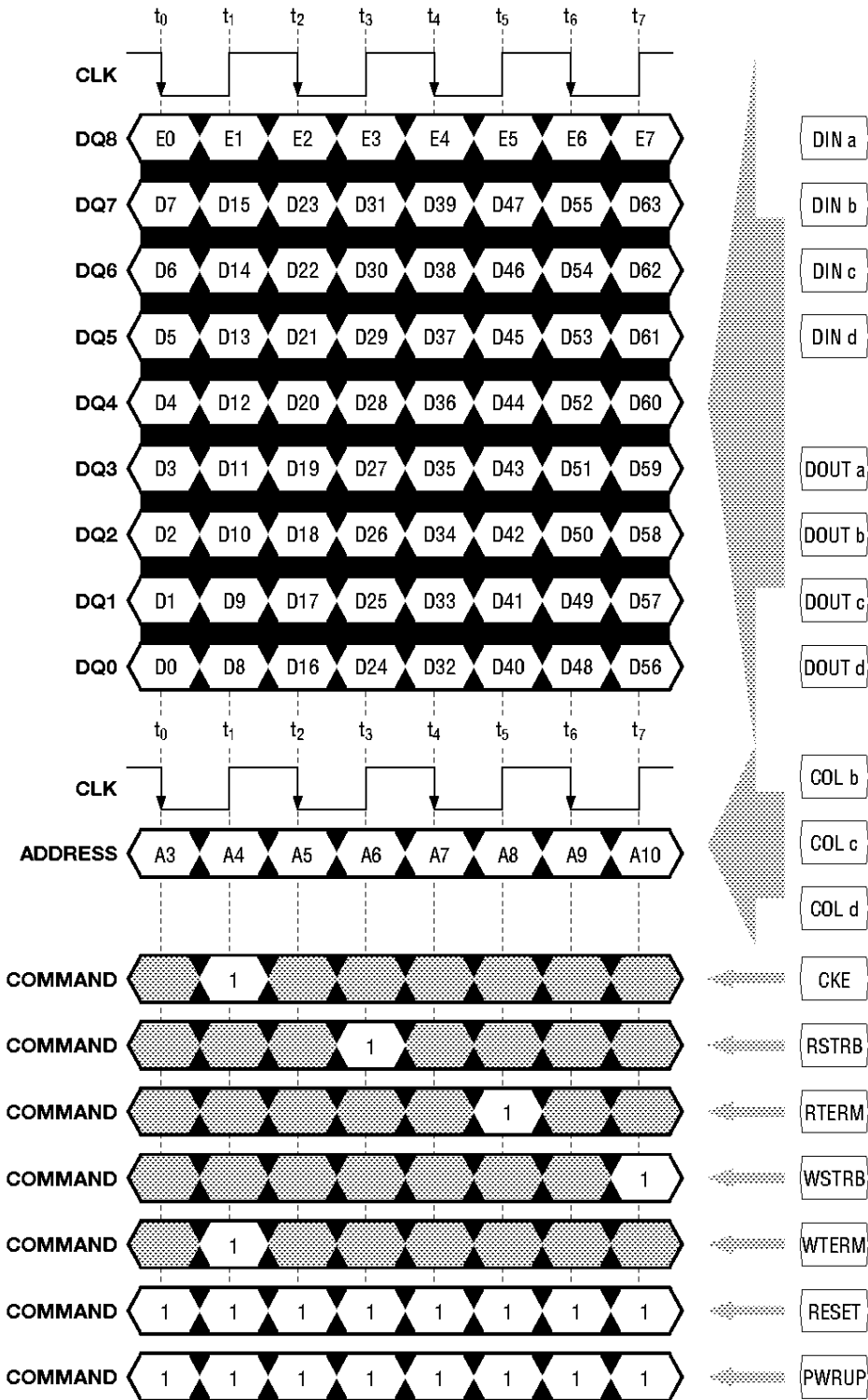

Fig. 7 DIN, DOUT, COL, CKE, RSTRB, RTERM, WSTRB, WTERM, and RESET Packet Formats

READ TRANSACTIONS

When a controller issues a read request to an RDRAM, one of three transaction cases will occur. This is a function of the request address and the state of the RDRAM.

READ: The first case is shown in Figure 8 (a). This occurs when the requested bank has been left in an activated state and the requested row address matches the address of this activated row. This is also called a page hit read and is invoked by the READ or READA commands.

There are three timing parameters which specify the positioning of the packets which control the data transfer. These are as follows:

t_{SDR}	Start of RSTRB to start of DOUT
t_{CDR}	Start of COL to start of DOUT
t_{TDR}	Start of RTERM to end of DOUT

These parameters are all expressed in units of t_{CYCLE} , and the minimum and maximum values are the same; the RSTRB, RTERM, COL, and DOUT packets move together as a block.

A fourth parameter has a minimum value only, and positions the block of data transfer packets relative to the REQ (address transfer) packet:

t_{RSR}	Start of REQ to start of RSTRB for READ
-----------	---

When a read transaction is formed, these packet constraints must be observed. In addition, there are constraints upon the timing of the bank operations which must also be observed. These are shown in Figure 8 (a) next to the label "Bank Operation". After the transfer of the REQ packet in T_0 , the RDRAM performs a column access (requiring t_{CAC} for the column access time) of the first data octbyte DOUTa during T_1 and T_2 . The RDRAM performs three column cycles (requiring t_{CC} for the column cycle time) in order to access the next three data octbytes (DOUTb, DOUTc, DOUTd) during T_3 , T_4 and T_5 . Each data octbyte is transferred one t_{PACKET} interval after it is accessed.

ACTV/READ: The second case is shown in Figure 8 (b). This occurs when the requested bank has been left in a precharged state. This is invoked by the ACTV/READ and ACTV/READA commands.

The RSTRB, RTERM, COL, and DOUT packets remain in the same relative positions as in the READ case, but they move further from the REQ packet:

t_{ASR}	Start of REQ to start of RSTRB for ACTV/READ
-----------	--

After the transfer of the REQ packet in T_0 , the RDRAM performs an activation operation (requiring t_{RCD} for the row-column delay) during T_1 and T_2 . This leaves the requested row activated. From this point the sequence of bank operations are identical to the READ case, except that everything has shifted two t_{PACKET} intervals further from the REQ packet. The sum of t_{RCD} and t_{CAC} is also known as t_{RAC} (the row access time).

PRE/ACTV/READ: The third case is shown in Figure 8 (c). This occurs when the requested bank has been left in an activated state and the requested row address doesn't match the address of this activated row. This is also called a page miss read and is invoked by the PRE/ACTV/READ and PRE/ACTV/READA commands. The RDRAM knows the difference between a PRE/ACTV/READ and a ACTV/READ because each RDRAM bank has a flag indicating whether it is precharged or activated. The external controller tracks this flag, and also tracks the address of each activated bank in order to distinguish READ and PRE/ACTV/READ accesses.

The RSTRB, RTERM, COL, and DOUT packets remain in the same relative positions as in the READ case, but they move further from the REQ packet:

$$t_{PSR} \quad \text{Start of REQ to start of RSTRB for PRE/ACTV/READ}$$

After the transfer of the REQ packet in T_0 , the RDRAM performs a precharge operation (t_{RP}) during T_1 and T_2 , and an activation operation (t_{RCD}) during T_3 and T_4 . This leaves the requested row activated. From this point the sequence of bank operations are identical to the READ case, except that everything has shifted four t_{PACKET} intervals further from the REQ packet. The sum of t_{RP} , t_{RCD} , and t_{CAC} is also known as t_{RC} (the row cycle time).

Auto-Precharge Option: For a READ, ACTV/READ, or a PRE/ACTV/READ command, the bank operations are complete once the last data octbyte has been accessed. The bank will be left with the requested row activated. For a READA, ACTV/READA, or a PRE/ACTV/READA command, there is an additional step. During the two t_{PACKET} intervals after the last data octbyte access, an auto-precharge operation (requiring t_{RPA} for the row precharge, auto) is performed. This leaves the bank in a precharged state.

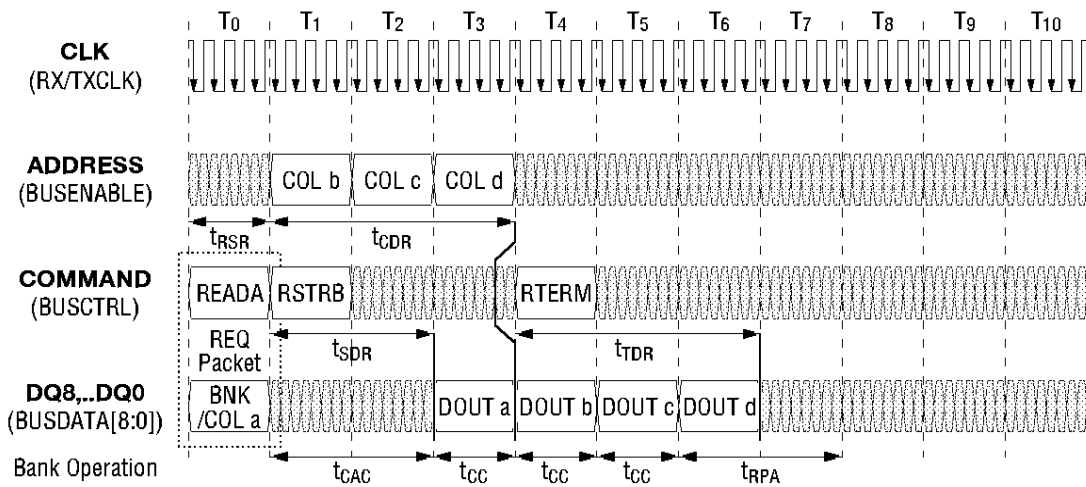

(a) READA - RANDOM READ CYCLES WITHIN A PAGE

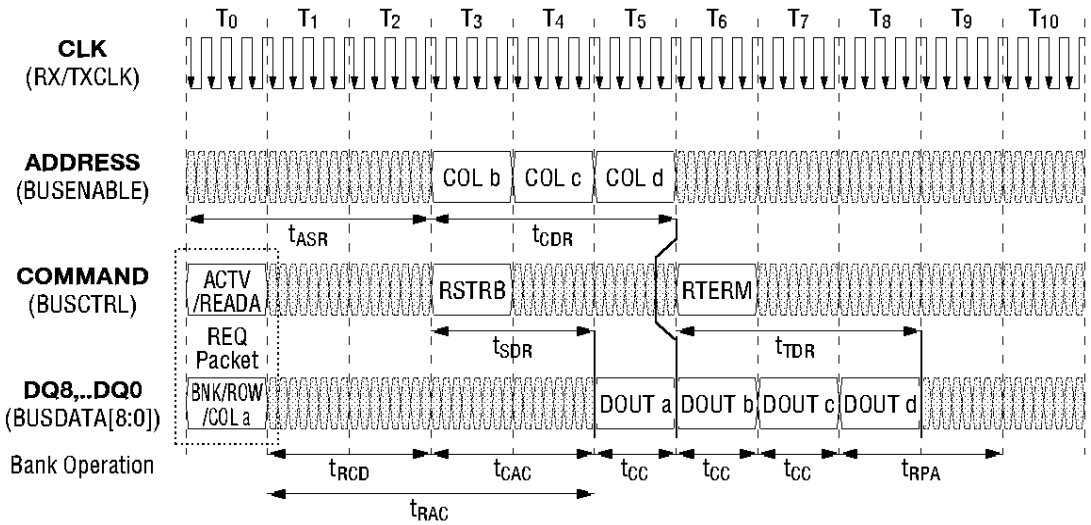

(b) ACTV/READA - BANK ACTIVATE AND RANDOM READ CYCLES WITHIN A PAGE

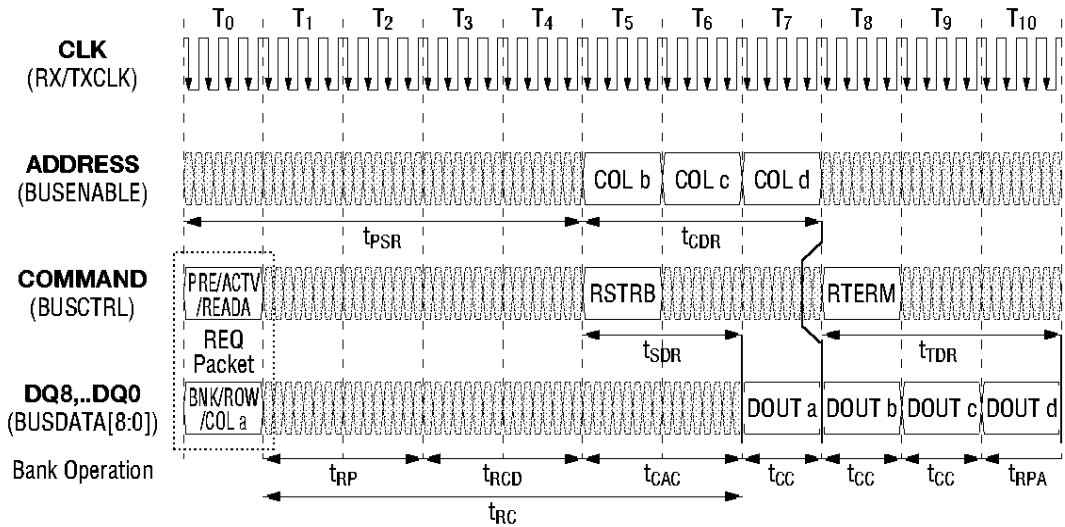

(c) PRE/ACTV/READA - BANK PRECHARGE/ACTIVATE AND RANDOM READ CYCLES IN A PAGE

Fig. 8 Read Transactions

WRITE TRANSACTIONS

When a controller issues a write request to an RDRAM, one of three transaction cases will occur. This is a function of the request address and the state of the RDRAM.

WRITE: The first case is shown in Figure 9 (a). This occurs when the requested bank has been left in an activated state and the requested row address matches the address of this activated row. This is called a page hit write and is invoked by the WRITE or WRITEA commands.

There are three timing parameters which specify the positioning of the packets which control the data transfer. These are as follows:

t_{SDW}	Start of WSTRB to start of DIN
t_{CDW}	Start of COL to start of DIN
t_{TDW}	Start of WTERM to end of DIN

These parameters are all expressed in units of t_{CYCLE} , and the minimum and maximum values are the same; the WSTRB, WTERM, COL, and DIN packets move together as a block.

A fourth parameter has a minimum value only, and positions the block of data transfer packets relative to the REQ (address transfer) packet:

t_{WSW}	Start of REQ to start of WSTRB for WRITE
-----------	--

When a write transaction is formed, these packet constraints must be observed. In addition, there are constraints upon the timing of the bank operations which must also be observed. These are shown in Figure 9 (a) next to the label "Bank Operation". After the transfer of the REQ packet in T_0 , the RDRAM performs a column access (requiring t_{CAC} for the column access time) of the first data octbyte $DINa$ during T_1 and T_2 . The RDRAM performs three column cycles (requiring t_{CC} for the column cycle time) in order to access the next three data octbytes ($DINb$, $DINc$, $DINd$) during T_3 , T_4 and T_5 . Each data octbyte is transferred one t_{PACKET} interval before it is accessed.

ACTV/WRITE: The second case is shown in Figure 9 (b). This occurs when the requested bank has been left in a precharged state. This is invoked by the ACTV/WRITE and ACTV/WRITEA commands.

The WSTRB, WTERM, COL, and DIN packets remain in the same relative positions as in the page hit case, but they move further from the REQ packet:

t_{ASW}	Start of REQ to start of WSTRB for ACTV/WRITE
-----------	---

After the transfer of the REQ packet in T_0 , the RDRAM performs an activation operation (called t_{RCD} or row-column delay) during T_1 and T_2 . This leaves the requested row activated. From this point the sequence of bank operations are identical to the WRITE case, except that everything has shifted two t_{PACKET} intervals further from the REQ packet. The sum of t_{RCD} and t_{CAC} is also known as t_{RAC} (the row access time).

PRE/ACTV/WRITE: The third case is shown in Figure 9 (c). This occurs when the requested bank has been left in an activated state and the requested row address doesn't match the address of this activated row. This is also called a page miss write and is invoked by the PRE/ACTV/WRITE and PRE/ACTV/WRITEA commands. The RDRAM knows the difference between a PRE/ACTV/WRITE and a ACTV/WRITE because each RDRAM bank has a flag indicating whether it is precharged or activated. The external controller tracks this flag, and also tracks the address of each activated bank in order to distinguish PRE/ACTV/WRITE and WRITE accesses.

The WSTRB, WTERM, COL, and DIN packets remain in the same relative positions as in the WRITE case, but they move further from the REQ packet:

$$t_{psw} \quad \text{Start of REQ to start of WSTRB for PRE/ACTV/WRITE}$$

After the transfer of the REQ packet in T_0 , the RDRAM performs a precharge operation (t_{RP}) during T_1 and T_2 , and an activation operation (t_{RCD}) of during T_3 and T_4 . This leaves the requested row activated. From this point the sequence of bank operations are identical to the WRITE case, except that everything has shifted four t_{PACKET} intervals further from the REQ packet. The sum of t_{RP} , t_{RCD} , and t_{CAC} is also known as t_{RC} (the row cycle time).

Auto-Precharge Option: For a WRITE, ACTV/WRITE or a PRE/ACTV/WRITE command, the bank operations are complete once the last data octbyte has been accessed. The bank will be left with the requested row activated. For a WRITEA, ACTV/WRITEA or a PRE/ACTV/WRITEA command, there is an additional step. During the two t_{PACKET} intervals after the last data octbyte access an auto-precharge operation (requiring t_{RPA} for the row precharge, auto) is performed. This leaves the bank in a precharged state.

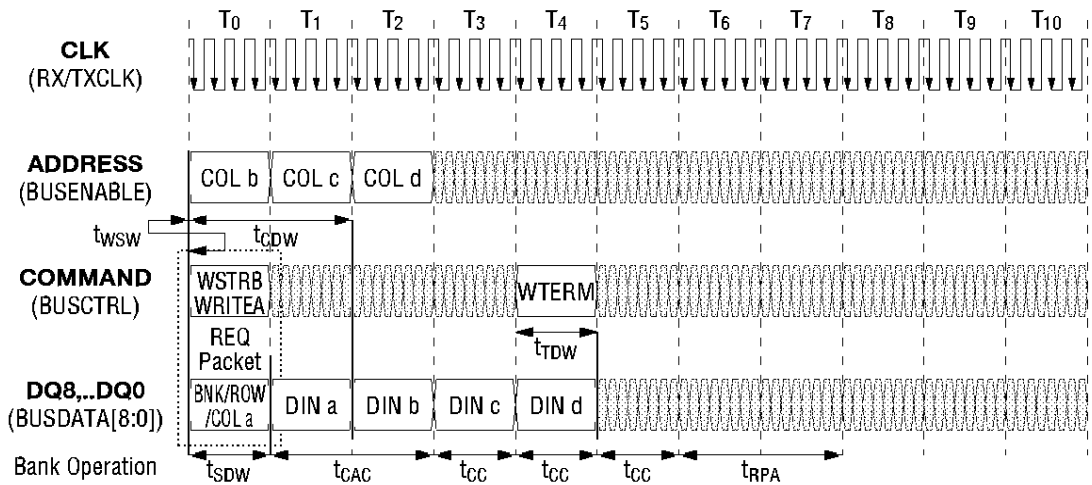

(a) WRITEA - RANDOM WRITE CYCLES WITHIN A PAGE

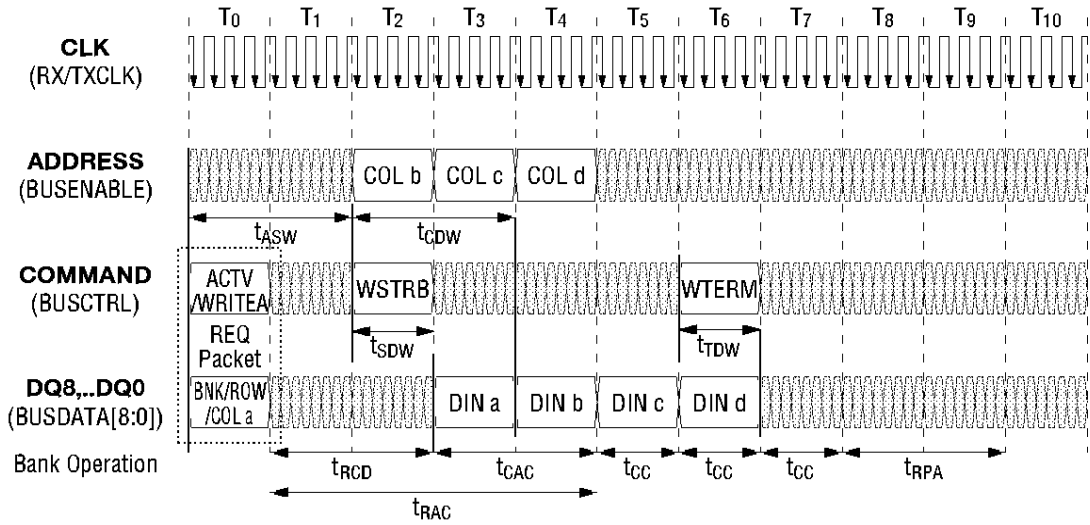

(b) ACTV/WRITEA - BANK ACTIVATE AND RANDOM WRITE CYCLES WITHIN A PAGE

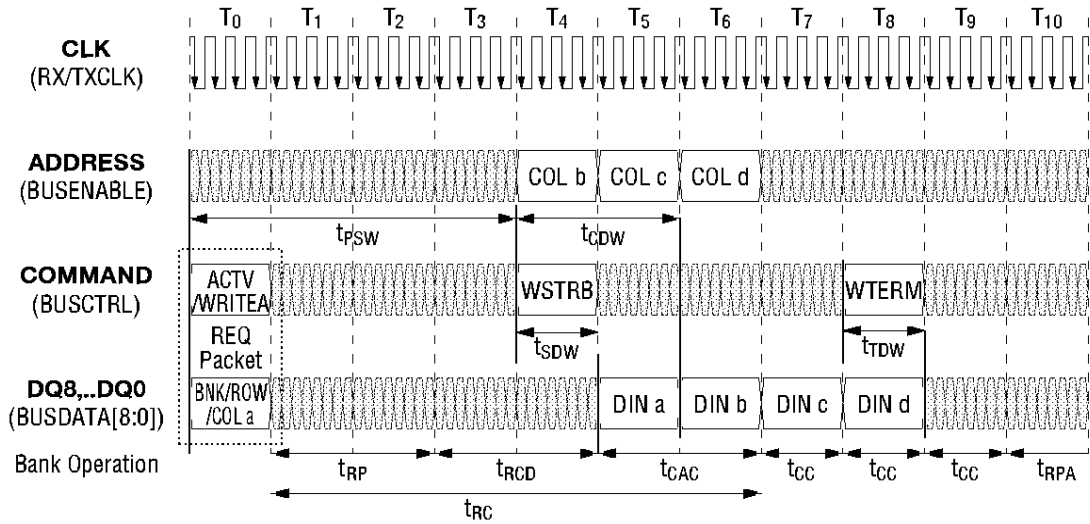

(c) PRE/ACTV/WRITEA - BANK PRECHARGE/ACTIVATE AND RANDOM WRITE CYCLES IN A PAGE

Fig. 9 Write Transactions

BYTEMASK OPERATIONS

All memory write transactions (OP1,OP0=01) use the M7..M0 field of the REQ packet to control byte masking of the first octabyte DINa of write data. M7 controls bits D56..D63,E7 while M0 controls bits D0..D7, E0. A "0" means don't write and a "1" means write.

The M7..M0 field should be filled with "00000000" for non-memory-write transactions.

OP2 = 1: When OP2 = 1 for a memory write transaction, the remaining data octabytes (DINb, DINc,...) are written unconditionally (all bytes are written).

OP2 = 0: When OP2 = 0, the remaining data octabytes (DINb, DINc,...) are written with a bytemask. Each bytemask is carried on the DQ8 wire, pipelined one t_{PACKET} interval ahead of the data octabyte it controls.

Figure 12 (b) shows the format of the M packet and DIN packet when OP2 = 0. M7 controls bits D56..D63 (of the next DIN packet) and M0 controls bits D0..D7 (of the next DIN packet). Figure 12 (a) summarizes the location of the M packets and the DIN packets they control.

When 64MRDRAM is used, there is no limitation caused by the use of bytemask operations; the DQ8 wire is only used for the REQ packet and M packets.

When 18MRDRAM is used, there is a limitation caused by the use of bytemask operations; the E7..E0 bits of the 72 bit DIN packet may not be used when OP2 = 0. To achieve bytemasking, it will be necessary to use read-modify-write operations or single-octabyte writes with the bytemask in the REQ packet and OP2 = 1.

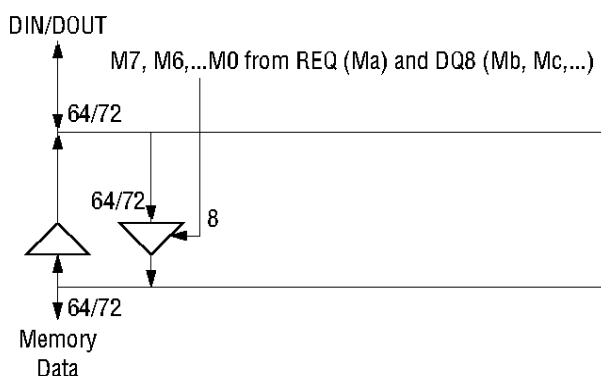

Fig. 10 Details of ByteMask Logic

BITMASK OPERATIONS

All memory write transactions (OP1,OP0 = 01) may use bitmask operations (OP5,OP4). Bitmask operations may be used simultaneously with the bytemask operations just described; a particular data bit is written only if the corresponding bytemask M and bitmask m are set.

OP5,OP4 = 00: This is the default option with no bitmask operation selected; all data bits are written, subject to any bytemask operation.

OP5,OP4 = 01: This is the write-per-bit option. Figure 13 (a) shows the transaction format. The 64/72-bit MASK register is used as a static bit mask, controlling whether each of the 64/72 bits of DIN octbytes is written (m = 1) or not written (m = 0). The MASK register is loaded using the dynamic bitmask operation (OP5,OP4 = 10).

OP5,OP4 = 10: This is the dynamic bitmask option. Figure 13 (b) shows the transaction format. Alternate octbytes (ma, mc,...) are loaded into the MASK register to be used as a bitmask for the data octbytes (DINb, DINd,...). Only the COL packets which correspond to DIN packets (COLb, COLd,...) contain a valid column address. The MASK register is left with the last bitmask that is transferred (mc in this case). The write-enable signal is asserted after DIN packet (Figure 11).

OP5,OP4 = 11: This is the mask-per-bit option. Figure 13 (c) shows the transaction format. The 64/72-bit MASK register is used as a static data octbyte DIN. The bitmask packets (ma, mb,...) control whether the data is written (m = 1) or not written (m = 0). The MASK register is loaded using the dynamic bitmask operation (OP5,OP4 = 10).

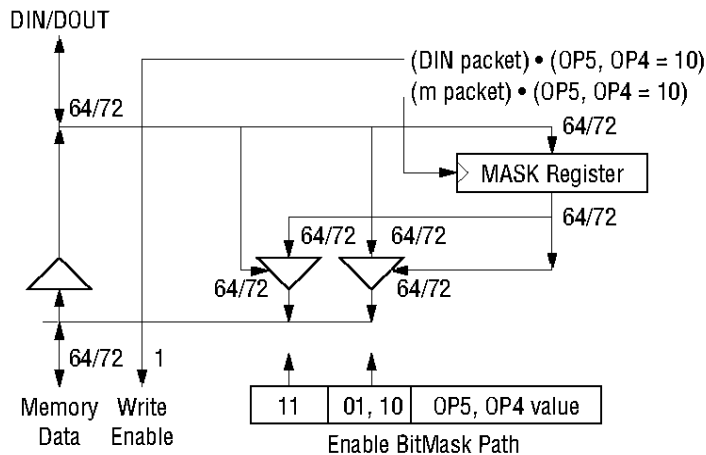
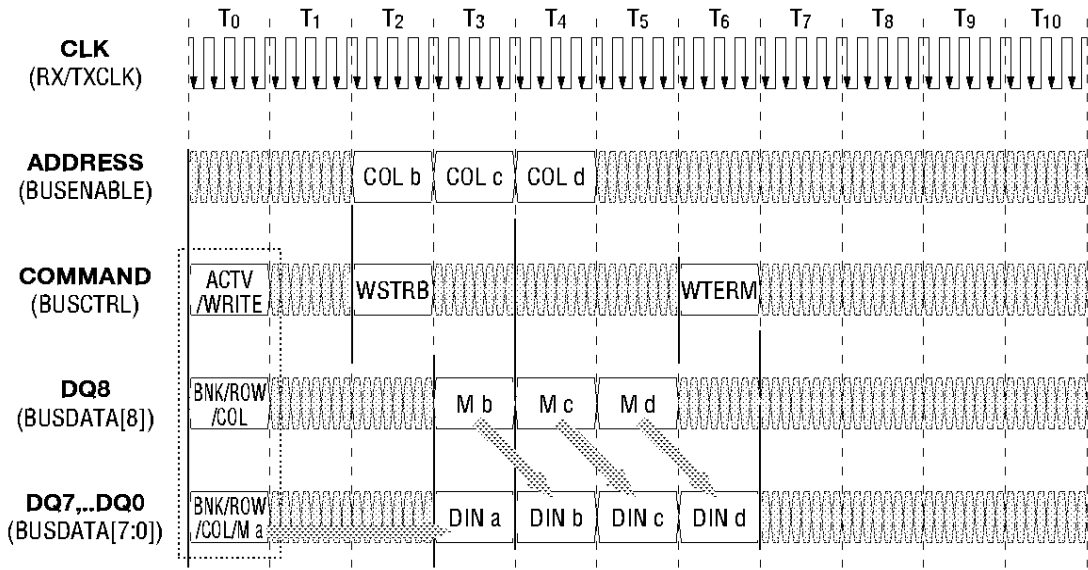
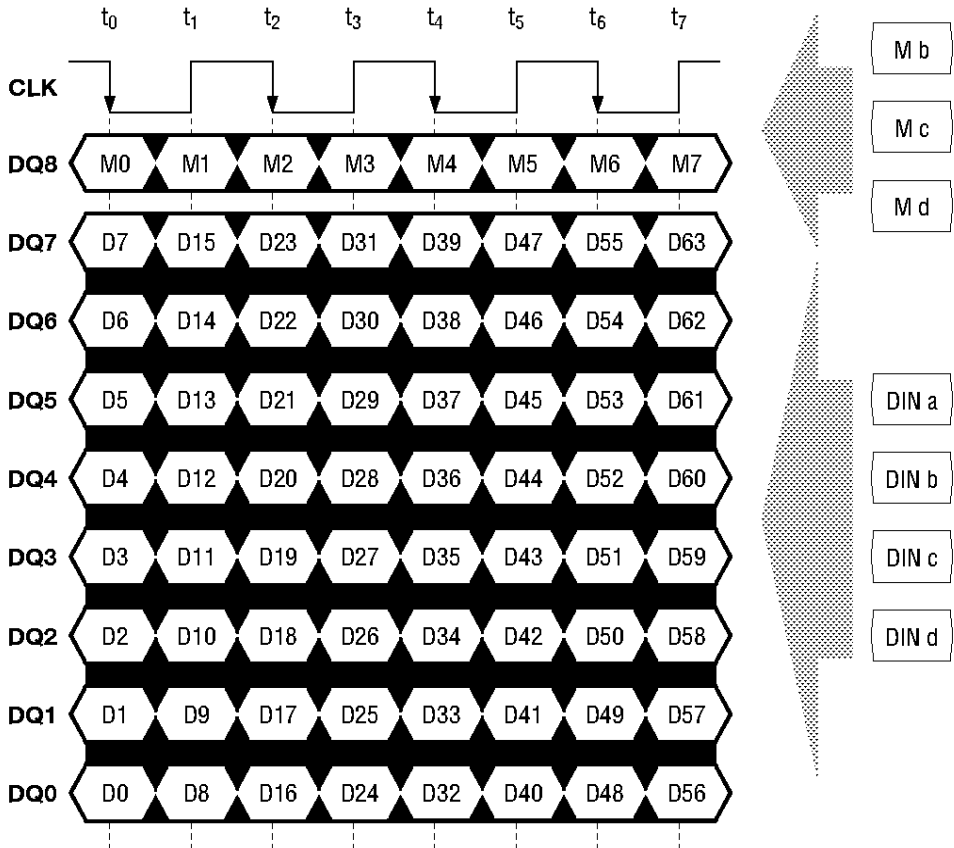

Fig. 11 Details of BitMask Logic



(a) OP2 = 0 - WRITE TRANSACTION WITH BYTEMASK



(b) OP2 = 0 - DATA AND BYTEMASK PACKET FORMATS

Fig. 12 ByteMask Operations

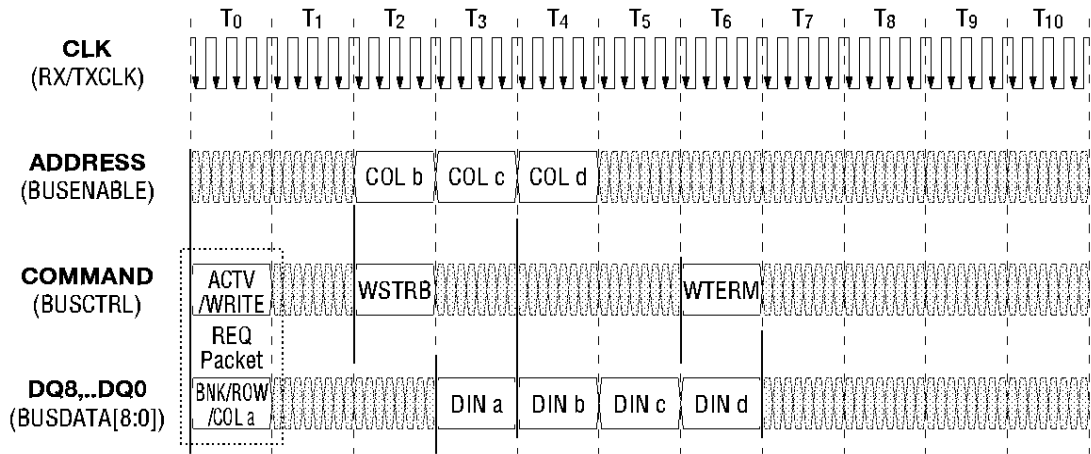

(a) OP5, OP4 = 0, 1 - BITMASK IN MASK REGISTER, DATA FROM DQ INPUTS

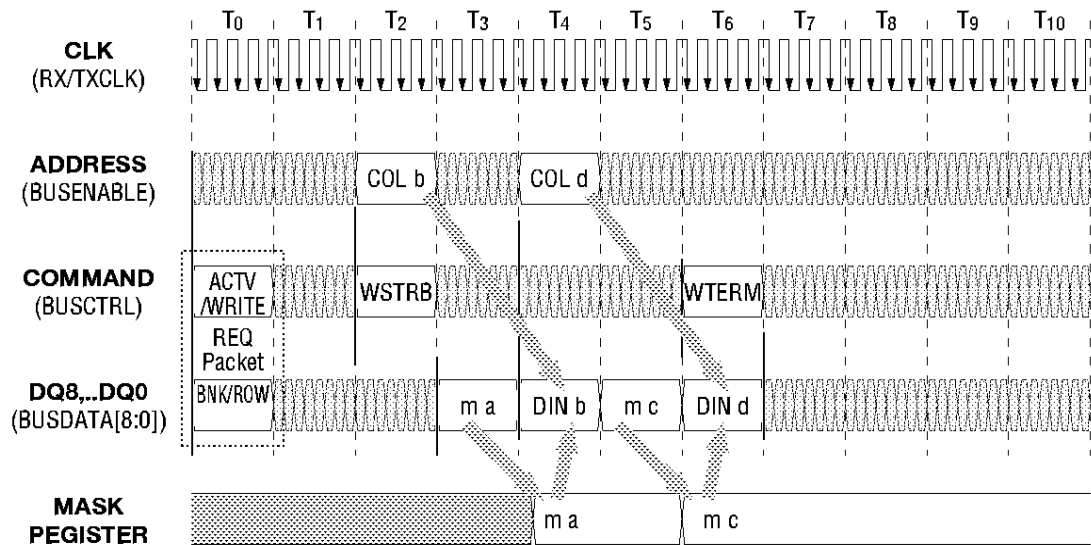

(b) OP5, OP4 = 1, 0 - BITMASK FROM DQ INPUTS, DATA FROM DQ INPUTS

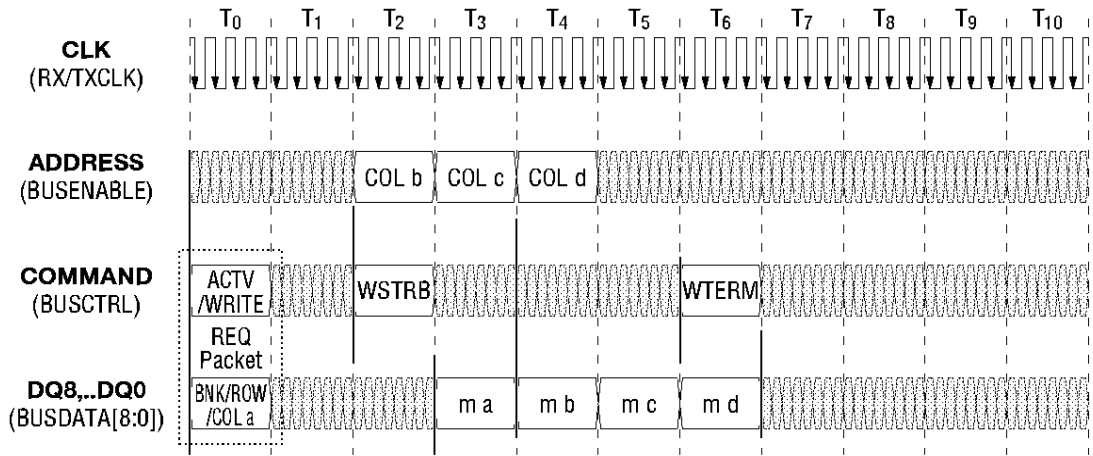

(c) OP5, OP4 = 1, 1 - BITMASK FROM DQ INPUTS, DATA IN MASK REGISTER

Fig. 13 BitMask Operations

REGISTERS

There are six control registers in an RDRAM. They contain read-only fields, which allow a memory controller to determine the type of RDRAM that is present. They also contain read-write fields which are used to configure the RDRAM.

Registers are read and written with transactions that are identical to one-octbyte memory read and write transactions. These transaction formats are illustrated in Figure 14. There is one difference with respect to memory transactions; for a register write, it is necessary to allow a time of t_{WREG} to elapse before another transaction is directed to the RDRAM.

In the descriptions of some of the read-write fields, the user is instructed to set the field to a default value ("Set to 1.", for example). When this is done, the suggested value is the one needed for normal operation of the RDRAM.

A summary of the control registers and a brief description follows

- DEVICETYPE RDRAM size, type information
- DEVICEID Set RDRAM base address
- MODE Set RDRAM operating modes
- REFROW Set refresh address for Powerdown
- RASINTERVAL Set RAS intervals
- DEVICEMFGR RDRAM manufacturer information

The control register fields are described in detail from Figure 15 to Figure 20. The format of the one octbyte DIN or DOUT packet that is written to or read from the register is shown. Gray bits are reserved, and should be written as zero. The value of the A10..A3,REGSEL field needed to access each register is also shown. The ROW and BANK address fields are not used for register read and write transactions.

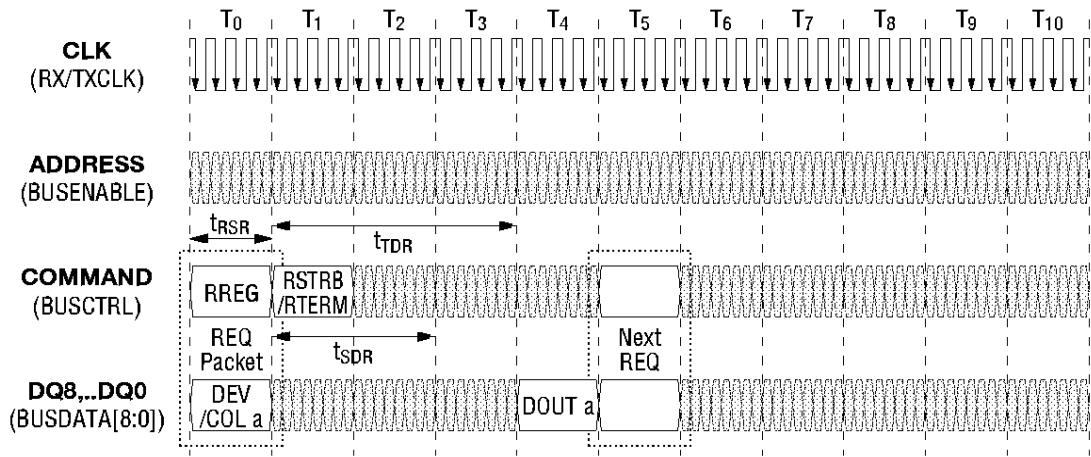

(a) REGISTER READ TRANSACTION

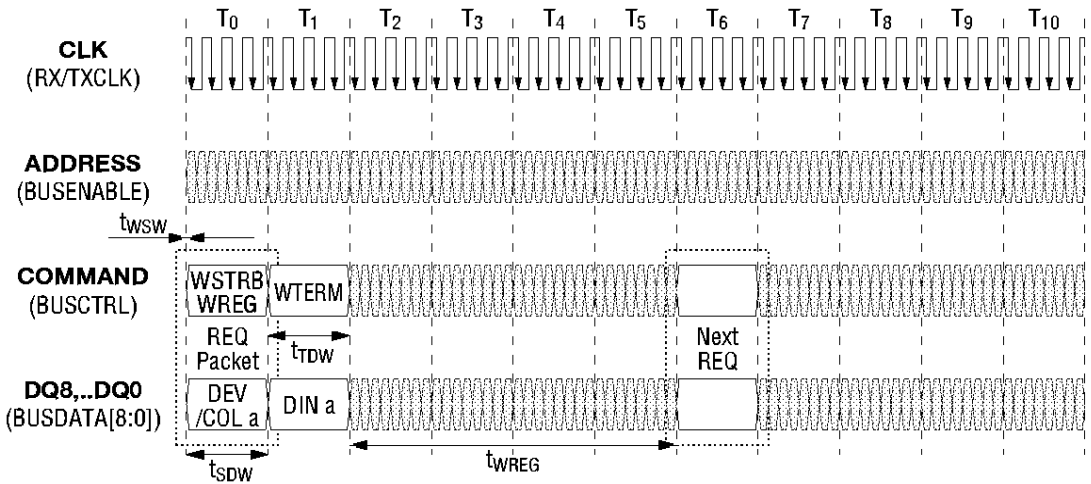

(b) REGISTER WRITE TRANSACTION

Fig. 14 Register Transactions

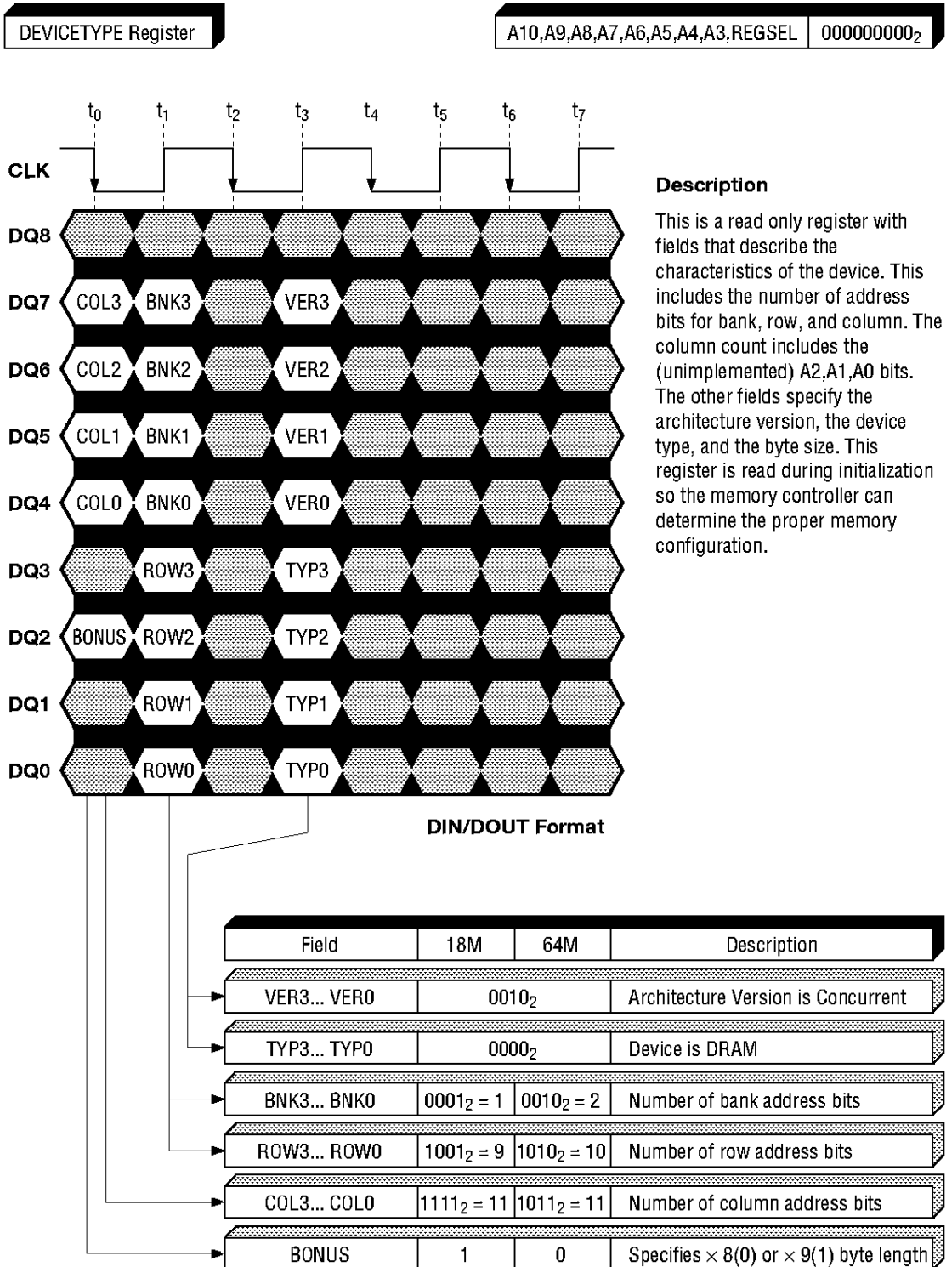
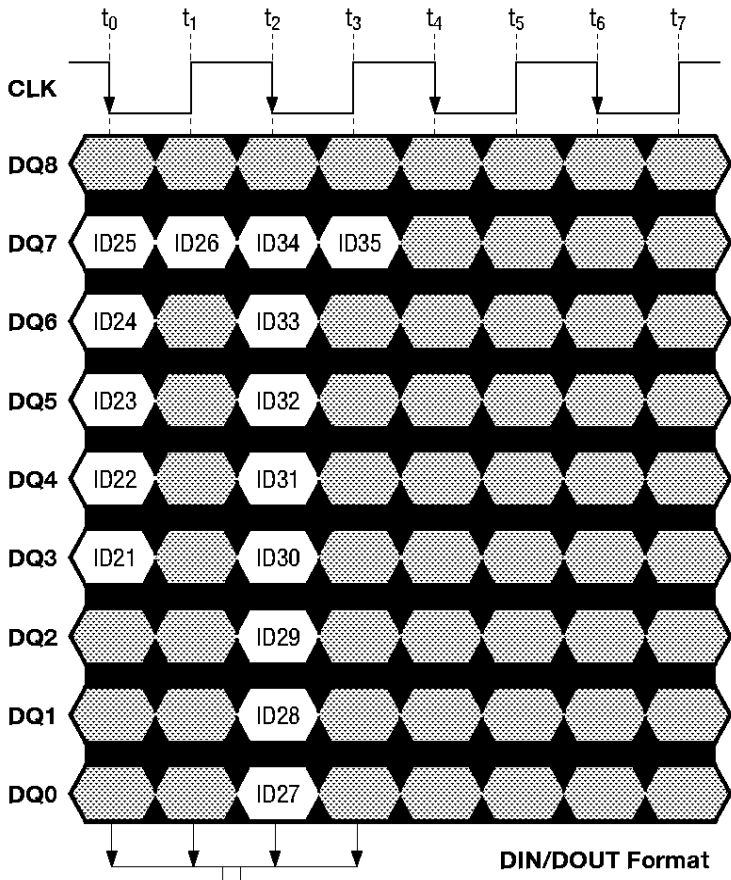

Fig. 15 DEVICETYPE Register

DEVICEID Register

A10,A9,A8,A7,A6,A5,A4,A3,REGSEL 000000001₂



Description

This is a read-write register with a single field ID35...ID21. This field is compared to the A35...A21 address bits of the REQ packet to determine if the current transaction is directed to this RDRAM. If the OP3 bit of the REQ packet is set, then this match is ignored (broadcast operation to all RDRAMs). Note that some low order bits of this field are not compared for the higher density RDRAMs.

DIN/DOUT Format

Field	RDRAM Size	Description
ID35..ID21	18M	Compared to A35...A21 for device match
ID35..ID23	64M	Compared to A35...A23 for device match

Fig. 16 DEVICEID Register

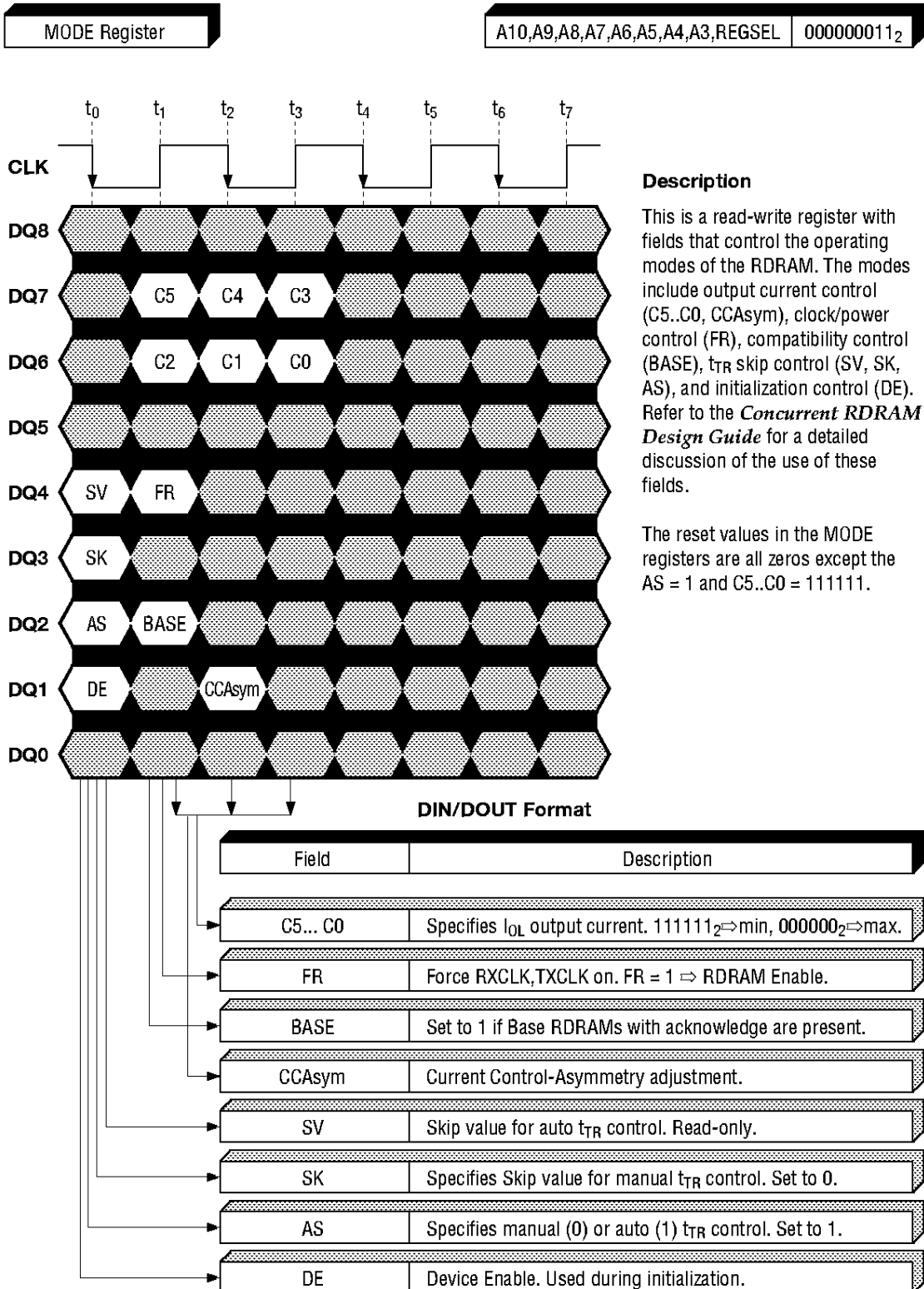
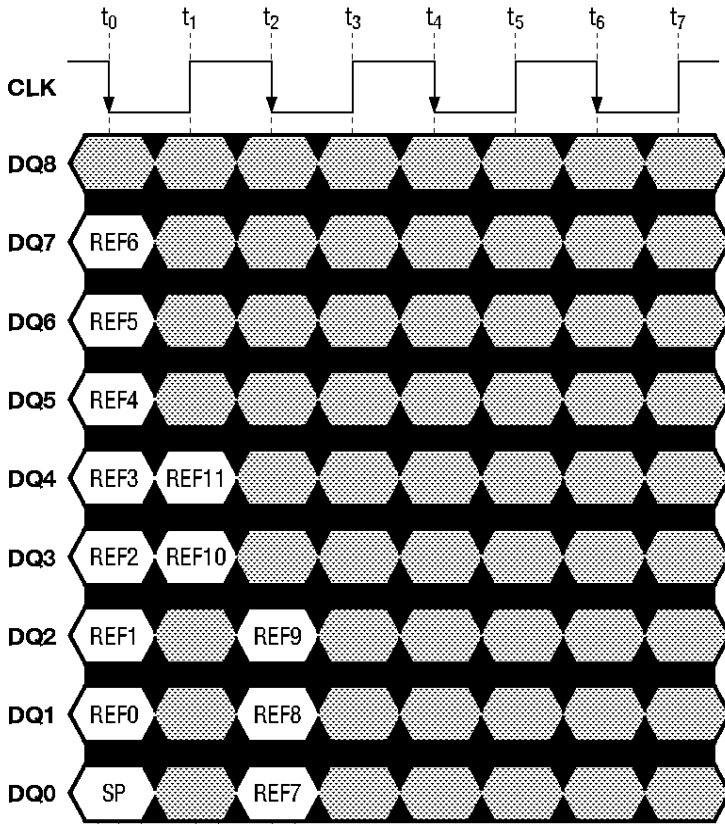

Fig. 17 MODE Register

REFROW Register

A10,A9,A8,A7,A6,A5,A4,A3,REGSEL 00000010₂



Description

This is a read-write register which is used to track the bank/row address that will be refreshed by the next SIN pulse in Powerdown mode. This register is not used for normal refresh in Enable mode - the bank/row address is supplied by the external controller in the refresh transaction.

Powerdown is entered by setting the SP field to one. The REF field should be simultaneously set with the next bank/row to be refreshed. When Powerdown is exited, this register is read from one RDRAM to set the proper bank/row address for normal refresh operation.

The reset value of the REFROW registers are all zeros.

DIN/DOUT Format

Field	RDRAM Size	Description
REF10	18M	Bank address of next row to be refreshed
REF11, REF10	64M	Bank address of next row to be refreshed
REF8...REF0	18M	Row address of next row to be refreshed
REF9...REF0	64M	Row address of next row to be refreshed
SP	—	Set to enter Powerdown mode.

Fig. 18 REFROW Register

RASINTERVAL Register

A10,A9,A8,A7,A6,A5,A4,A3,REGSEL 000000110₂

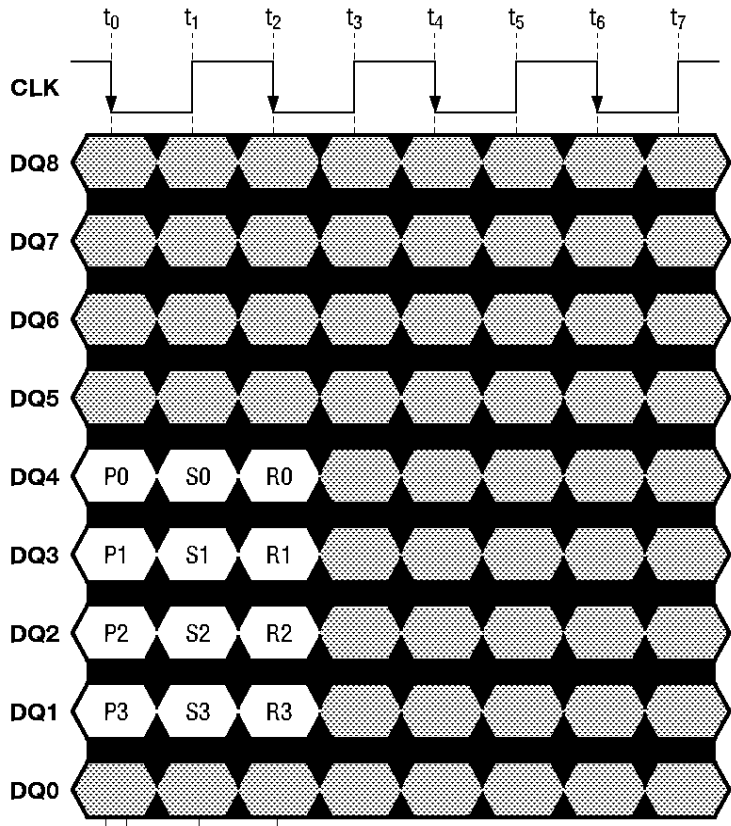

Description

This is a read-write register with fields that control the length of the RAS intervals of the RDRAM. The relationship between the t_{RC} , t_{RCD} , t_{RPA} and t_{RP} intervals (in t_{CYCLE} units) and the P, S, and R fields follows:

$$t_{RC} = (1001_2 + R + S + P) \cdot t_{CYCLE}$$

$$t_{RCD} = (0101_2 + S) \cdot t_{CYCLE}$$

$$t_{RP} = (0101_2 + P) \cdot t_{CYCLE}$$

$$t_{RPA} = (0101_2 + P) \cdot t_{CYCLE}$$

DIN/DOUT Format

Field	Description
R3...R0	Specifies the ($t_{RC} - t_{RCD} - t_{RP}$) restore interval. Set to 0111 ₂ .
S3...S0	Specifies the t_{RCD} sense interval. Set to 0011 ₂ .
P3...P0	Specifies the t_{RP} and t_{RPA} precharge intervals. Set to 0011 ₂ .

Fig. 19 RASINTERVAL Register

DEVICEMFGR Register

A10,A9,A8,A7,A6,A5,A4,A3,REGSEL 000001001₂

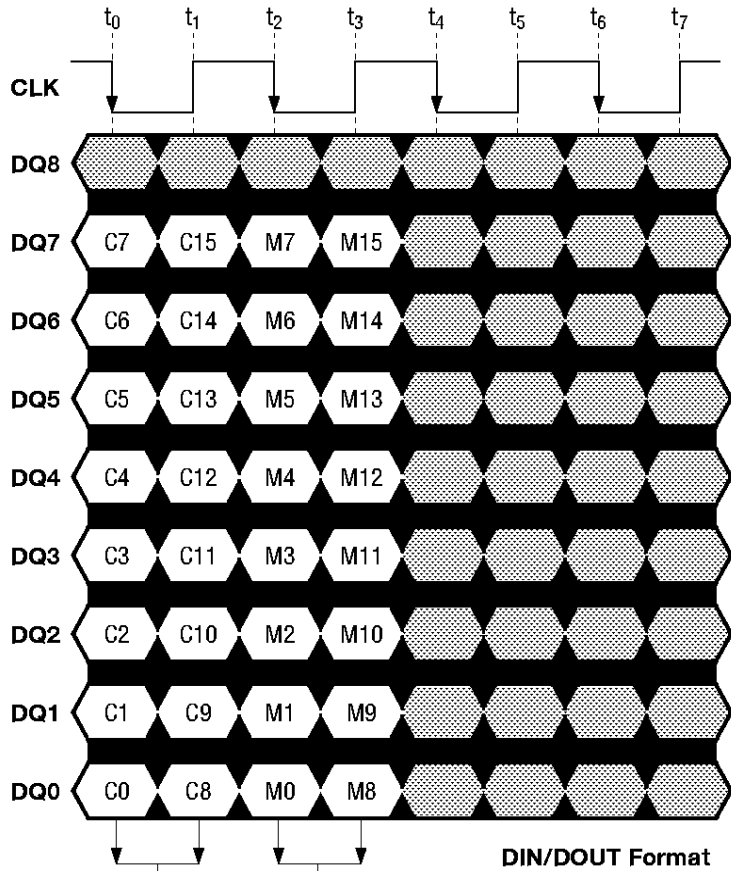

Description

This is a read-only register with fields that specify the manufacturer's identification number and manufacturer-specific date-code and version information.

Contact Rambus for a list of manufacturer's identification numbers.

DIN/DOUT Format

Field	Description
M15...M0	Manufacturer's identification number
C15...C0	Manufacturer's datecode or version information

Fig. 20 DEVICEMFGR Register

INITIALIZATION

The first step in initialization is to reset the RDRAM. This is accomplished by driving RESET packets for a time t_{RESET} or greater. This causes the RDRAM to assume a known state. This also causes the internal clocking logic (a delay-locked-loop) to begin locking to the external clock. This requires a time of t_{LOCK} . At this point, the RDRAM is ready to accept transactions. This timing sequence is shown in Figure 21 (a).

The next step for the memory controller is to read and write the six control registers, in order to determine the size and type of RDRAM that is present, and to configure it properly. A full initialization sequence is provided in the *Concurrent RDRAM Design Guide*.

POWER MANAGEMENT

There are several power modes available in an RDRAM. These modes permit power dissipation and latency to be traded against one another.

Enable Mode: The simplest option is to remain permanently in Enable power mode. This is done by setting the FR field to a one in the MODE register (refer to Figure 17). The RDRAM will return to Enable mode when it is not performing a read or write transaction. This is the operating mode which has been assumed in all the transaction timing diagrams (except in Figure 21 (b)).

Suspend Mode: The average power can be reduced by using Suspend power mode. This is done by setting the FR field to a zero. A CKE packet must be sent a time t_{CKE} ahead of each REQ packet (this is shown in T_0 in Figure 21 (b)). This causes the RDRAM to transition from Suspend to Enable mode. When the RDRAM has finished the transaction, it returns to Suspend mode. The average power of the RDRAM is reduced, but at the cost of slightly greater latency. There is no loss of effective bandwidth, since the CKE packet may be overlapped with the other packet types.

Powerdown Mode: The RDRAM power can be reduced to a very low level with Powerdown mode. Powerdown is entered by setting the SP field of the REFROW register to one (the REF field is simultaneously set to the next bank and row to be refreshed). As a result, most of the RDRAM's circuitry is disabled, although its memory must still be refreshed. This is accomplished by pulsing the SIN input with a cycle time of t_{CYCLE} or less.

Powerdown mode is exited when PWRUP packets are asserted for a time t_{PWRUP} on the Command wire. The internal clocking logic will begin locking to the external clock. After a time of t_{LOCK} the RDRAM will be in Enable mode, ready for the next REQ packet. This is illustrated in Figure 21 (c).

REFRESH

Memory refresh (when not in Powerdown) uses a one-octbyte broadcast memory write with the following REQ field values:

OP5..0	001001 ₂	A35..3	DEV:	0..0 (unused)
AUTO	1		BNK:	next bank
ACTV	1		ROW:	next row
PEND	000/001/010		COL:	0..0 (unused)
M7..0	00000000 ₂		REGSEL:	0

The transaction format for memory refresh is shown in Figure 22 (a). The transaction may be noninterleaved or interleaved (if interleaved, the PEND field must be properly filled). The transaction causes the requested row of the requested bank of *all* RDRAMs to be activated and then auto-precharged (note that the interval $t_{RP} + t_{RCD}$ should elapse since the specified bank of some RDRAMs might be open). This transaction must be repeated at intervals of $t_{REF} / (N_{BNK} \cdot N_{ROW})$, where N_{BNK} and N_{ROW} are the number of banks and rows in the RDRAM. This interval will be the same for the different RDRAM configurations. For each refresh transaction, the bank and row field of A35..A3 must be incremented, with the bank field changing most often so the $t_{RAS,MAX}$ parameter is not exceeded.

CURRENT CONTROL

The transaction format for current control is shown in Figure 22 (b). This transaction is encoded as a directed register read operations, and is repeated at intervals of t_{CCTRL} / N_{DEV} , where N_{DEV} is the number of devices on the Channel. This will maintain the optimal current control value.

OP5..0	000110 ₂	A35..3	DEV:	next device
AUTO	0		BNK:	0..0 (unused)
ACTV	0		ROW:	0..0 (unused)
PEND	000		COL:	00000101 ₂
M7..0	00000000 ₂		REGSEL:	0

After a t_{LOCK} , a series of 64 of these current control transactions must be directed to each device on the Channel to establish the optimal current control value.

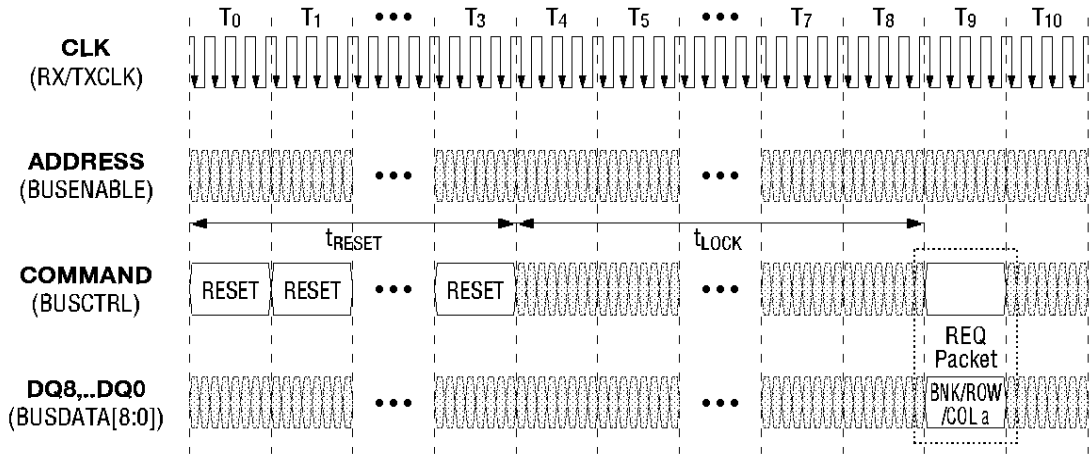

(a) RESET PACKET FOR INITIALIZATION

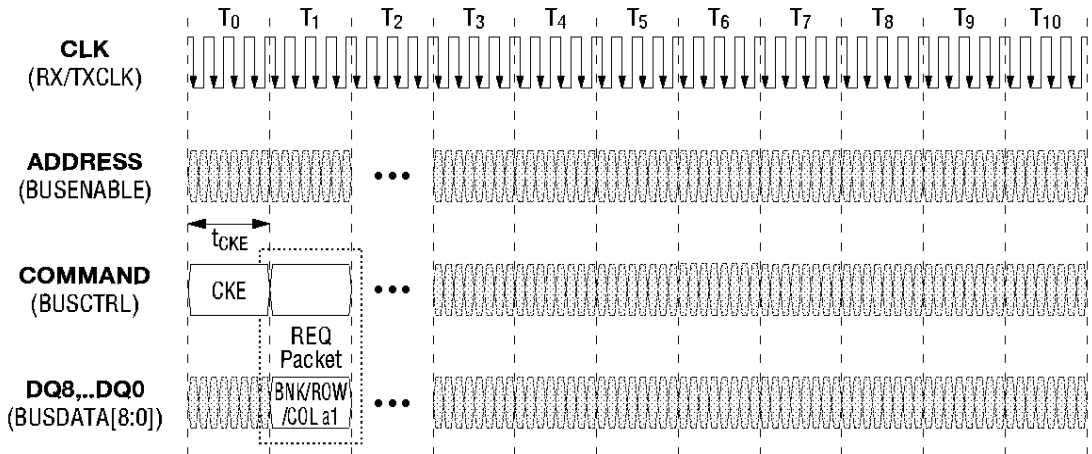

(b) CKE PACKET FOR SUSPEND-TO-ENABLE POWER MODE TRANSITION

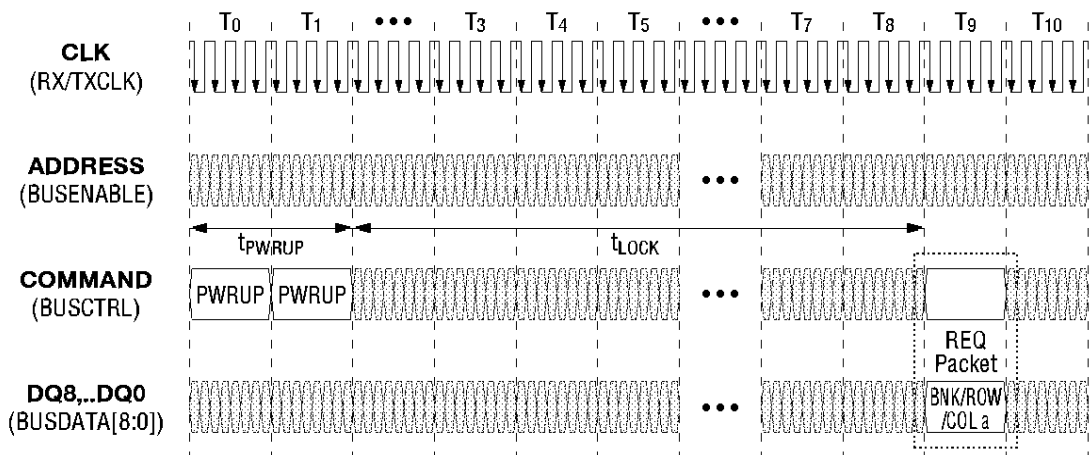

(c) PWRUP PACKET FOR POWERDOWN-TO-ENABLE POWER MODE TRANSITION

Fig. 21 Transactions using RESET, CKE, and PWRUP Packets

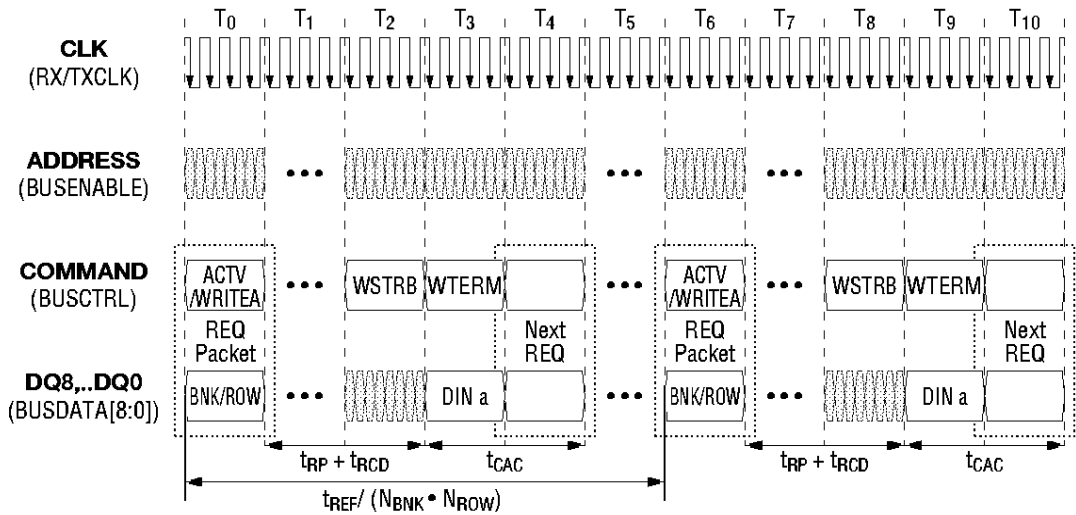

(a) REFRESH TRANSACTION

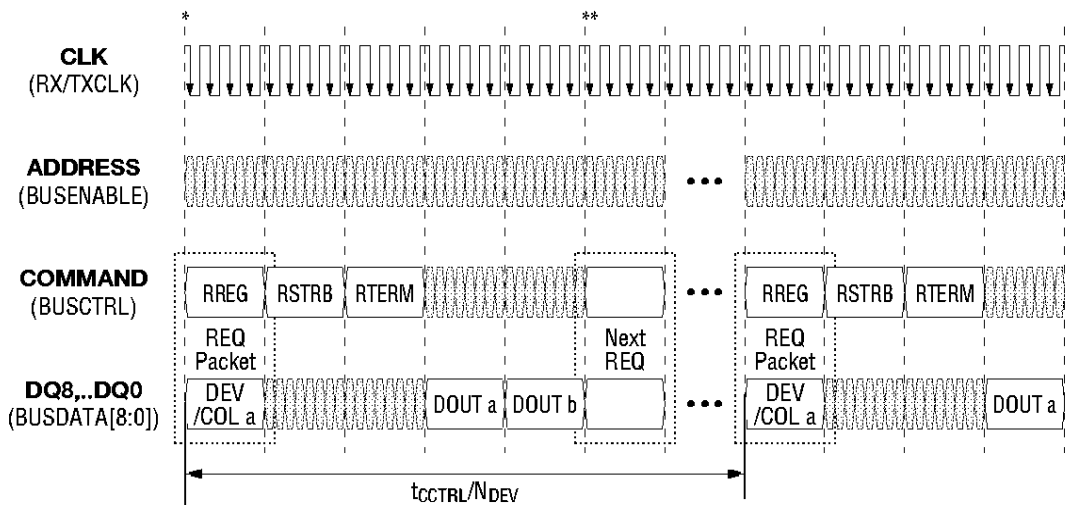

(b) CURRENT CONTROL TRANSACTION

Fig. 22 Refresh and Current Control Transactions

Due to the nature of the current control operation, a delay of 4 BusClks may be needed before and after the current control transaction.

If the request immediately before the current control request is a write request, there should be a 4 BusClks (1 Synclk) delay between the end of write data and the beginning of the RDRAM current control request (see * in Figure 22 (b)). If the request immediately before the current control request is a read request, no delay is required.

If the current control data is followed by a request using the MODE register address, there must be a 4BusClks (1 Synclk) delay between the end of current control data transport and the subsequent requests using the MODE register addresses (see ** in Figure 22 (b)). Any other request may immediately follow the current control data transport.

ABSOLUTE MAXIMUM RATINGS

The following table represents stress ratings only, and functional operation at the maximum ratings is not guaranteed. Extended exposure to the maximum ratings may affect device reliability. Although these devices contain protective circuitry to resist damage from static electric discharge, always take precautions to avoid high static voltages or electric fields.

Symbol	Parameter	Min.	Max.	Unit
$V_{I,ABS}$	Voltage applied to any RSL pin with respect to Gnd	-0.3	$V_{DD,MAX}+0.3$	V
$V_{I,CMOS,ABS}$	Voltage applied to any CMOS pin with respect to Gnd	-0.3	$V_{DD}+0.3$	V
$V_{DD,ABS}$	Voltage on V_{DD} with respect to Gnd	-0.3	$V_{DD,MAX}+1.0$	V
$T_{J,ABS}$	Junction temperature under bias	-55	125	°C
T_{STORE}	Storage temperature	-55	125	°C

CAPACITANCE

Symbol	Parameter and Conditions	Min.	Max.	Unit
C_I	RSL input parasitic capacitance	1.6 ^a /2.0 ^b	2.0 ^a /2.5 ^b	pF
L_I	RSL input parasitic inductance	—	2.7 ^a /5.0 ^b	nH
$C_{I,CMOS}$	CMOS input parasitic capacitance	—	8	pF

Notes:

- a. 18M RDRAM
- b. 64M RDRAM

IDD-SUPPLY CURRENT PROFILE

($T_a = 0^\circ\text{C}$ to 70°C)

Mode	Description	Min.	Max.	Unit
Powerdown	Device shut down, clock unlocked	—	1.0 ^a /1.5 ^b	mA
Suspend	Device inactive, clock locked but Suspended	—	115 ^a /185 ^b	mA
Enable	Device active, clock unlocked and Enabled	—	380 ^a /400 ^b	mA
READ	Device reading column data	—	590	mA
WRITE	Device writing column data	—	495	mA
ACTV/READ	Device reading column data in bank 1 and activating row in bank 2	—	700	mA
ACTV/WRITE	Device writing column data in bank 1 and activating row in bank 2	—	660	mA

Notes:

- a. 18M RDRAM
- b. 64M RDRAM

RECOMMENDED ELECTRICAL CONDITIONS

(Ta = 0°C to 70°C)

Symbol	Parameter and Conditions	Min.	Max.	Unit
V _{DD} , V _{DDA}	Supply voltage — 3.3 V version	3.15	3.45	V
V _{REF}	Reference voltage	1.9	V _{DD} -0.8	V
V _{IL}	RSL Input low voltage ^b	V _{REF} -0.35	V _{REF} -0.8	V
V _{IH}	RSL Input high voltage ^b	V _{REF} +0.35	V _{REF} +0.8	V
V _{IL,CMOS}	CMOS input low voltage	-0.5	0.8	V
V _{IH,CMOS}	CMOS input high voltage	1.8	V _{DD} +0.5	V

ELECTRICAL CHARACTERISTICS

(Ta = 0°C to 70°C)

Symbol	Parameter and Conditions	Min.	Max.	Unit
I _{REF}	V _{REF} CURRENT @ V _{REF,MAX}	-10	10	μA
I _{OH}	RSL output high current @ (0 ≤ V _{OUT} ≤ V _{DD})	-10	10	μA
I _{NONE} (manual)	RSL I _{OL} current @ V _{OUT} = 1.6 V @ C[5:0] = 000000 (0 ₁₀) ^a	0.0	4.0	mA
I _{ALL} (manual)	RSL I _{OL} current @ V _{OUT} = 1.6 V @ C[5:0] = 111111 (63 ₁₀) ^a	30.0	80.0	mA
I _{I,CMOS}	CMOS input leakage current @ (0 ≤ V _{I,CMOS} ≤ V _{DD})	-10.0	10.0	μA
V _{OL,CMOS}	CMOS output voltage @ I _{OL,CMOS} = 1.0 mA	0.0	0.4	V
V _{OH,CMOS}	CMOS output high voltage @ I _{OH,CMOS} = -0.25 mA	2.0	V _{DD}	V

Notes:

- In manual-calibration mode (CCEnable = 0) this is the value written into the C[5:0] field of the Mode register to produce the indicated I_{OL} value. Values of I_{OL} in between the I_{NONE} and I_{ALL} are produced by interpolating C[5:0] to intermediate values. For example, C[5:0] = 011111 (31₁₀) produces an I_{OL} in the range of 15 to 40 mA.
- I_{OL} of Bus Data outputs is set at 30 mA when Bus Enable pin V_{IH}/V_{IL} value is measured.

RECOMMENDED TIMING CONDITIONS

(Ta = 0°C to 70°C)

Symbol	Parameter	Min.	Max.	Unit
t _{GR} , t _{CF}	TXCLK and RXCLK input rise and fall times	0.3	0.8	ns
t _{CYCLE}	TXCLK and RXCLK cycle times	3.75 ^a /3.33 ^b	4.15 ^a /4.15 ^b	ns
t _{TICK}	Transfer time per bit per pin (this timing interval is synthesized by the RDRAM's clock generator)	0.5	0.5	t _{CYCLE}
t _{CH} , t _{CL}	TXCLK and RXCLK high and low times	45%	55%	t _{CYCLE}
t _{TR}	TXCLK-RXCLK differential	0	0.7	t _{CYCLE}
t _{PACKET}	Transfer time for REQ, DIN, DOUT, COL, WSTRB, WTERM, RSTRB, RTERM, CKE, PWRUP and RESET packets	4	4	t _{CYCLE}
t _{DR} , t _{DF}	DQ/ADDRESS/COMMAND input rise and fall times	0.3	0.6	ns
t _S	DQ/ADDRESS/COMMAND-to-RXCLK setup time	0.35	—	ns
t _H	RXCLK-to-DQ/ADDRESS/COMMAND hold time	0.35	—	ns
t _{REF}	Refresh interval	—	17 ^c /33 ^d	ms
t _{SCYCLE}	Powerdown refresh cycle time	0.4	16.6 ^c /8.0 ^d	μs
t _{SL}	Powerdown refresh low time	0.2	10 ^c /7.8 ^d	μs
t _{SH}	Powerdown refresh high time	0.2	10 ^c /7.8 ^d	μs
t _{CCTRL}	Current control interval	—	150	ms
t _{RAS}	RAS interval (time a row may stay activated)	—	133	μs
t _{LOCK}	RDRAM clock-locking time for reset or powerup	—	5.0	μs

Notes:

- a. 533 MHz RDRAM
- b. 600 MHz RDRAM
- c. 18M RDRAM
- d. 64M RDRAM

TIMING CHARACTERISTICS

(Ta = 0°C to 70°C)

Symbol	Parameter	Min.	Max.	Unit
t _{PIO}	SIn-to-SOut delay @ C _{LOAD,CMOS} = 40 pF	—	25	ns
t _Q	DQ output time	-0.4	0.4	ns
t _{QR} , t _{QF}	DQ output rise and fall times	0.3	0.5	ns

RAMBUS CHANNEL TIMING

The next table shows important timings on the Rambus channel for common operations. All timings are from the point of view of the channel master, and thus have the bus overhead delay of t_{CYCLE} per bus transversal included where appropriate.

(Ta = 0°C to 70°C)

Symbol and Figure	Parameter	Min.	Max.
t _{CAC} - Figure 8,9	Column <u>A</u> ccess time. May overlap t _{RCD} , t _{RP} , or t _{RPA} to another bank	6 ^a /7 ^b	—
t _{CC} - Figure 8,9	Column <u>C</u> ycle time. May overlap t _{RCD} , t _{RP} , or t _{RPA} to another bank	4	—
t _{RCD} - Figure 8,9	Row to Column <u>D</u> elay. May overlap t _{CAC} or t _{CC} to another bank	8	—
t _{RP} - Figure 8,9	Row <u>P</u> recharge time. May overlap t _{CAC} or t _{CC} to another bank	8	—
t _{RPA} - Figure 8,9	Row <u>P</u> recharge <u>A</u> uto. May overlap t _{RPA} , t _{CAC} or t _{CC} to another bank	8	—
t _{RAC} - Figure 8,9	Row <u>A</u> ccess time. (t _{RAC} = t _{RCD} + t _{CAC}).	15	—
t _{RC} - Figure 8,9	Row <u>C</u> ycle time. (t _{RC} = t _{RP} + t _{RCD} + t _{CAC}).	23	—
t _{RSR} - Figure 8 (a)	Start of REQ (<u>R</u> EAD) to start of R <u>S</u> TRB packet for <u>R</u> ead transaction.	2	—
t _{ASR} - Figure 8 (b)	Start of REQ (<u>A</u> CTV/ <u>R</u> EAD) to start of R <u>S</u> TRB packet for <u>R</u> ead transaction.	11	—
t _{PSR} - Figure 8 (c)	Start of REQ (<u>P</u> RE/ <u>A</u> CTV/ <u>R</u> EAD) to start of R <u>S</u> TRB packet for <u>R</u> ead transaction.	19	—
t _{CDR} - Figure 8	Start of <u>C</u> OL packet to start of <u>D</u> OUT packet for <u>R</u> ead transaction.	12	12
t _{SDR} - Figure 8	Start of R <u>S</u> TRB packet to start of <u>D</u> OUT packet for <u>R</u> ead transaction.	8	8
t _{TDR} - Figure 8	Start of R <u>T</u> ERM packet to end of <u>D</u> OUT packet for <u>R</u> ead transaction.	12	12
t _{WSW} - Figure 9 (a)	Start of REQ (<u>W</u> RITE) to start of W <u>S</u> TRB packet for <u>W</u> rite transaction.	0	—
t _{ASW} - Figure 9 (b)	Start of REQ (<u>A</u> CTV/ <u>W</u> RITE) to start of W <u>S</u> TRB packet for <u>W</u> rite transaction.	5	—
t _{PSW} - Figure 9 (c)	Start of REQ (<u>P</u> RE/ <u>A</u> CTV/ <u>W</u> RITE) to start of W <u>S</u> TRB packet for <u>W</u> rite transaction.	13	—
t _{CDW} - Figure 9	Start of <u>C</u> OL packet to start of <u>D</u> IN packet for <u>W</u> rite transaction.	8	8
t _{SDW} - Figure 9	Start of W <u>S</u> TRB packet to start of <u>D</u> IN packet for <u>W</u> rite transaction.	4	4
t _{TDW} - Figure 9	Start of W <u>T</u> ERM packet to end of <u>D</u> IN packet for <u>W</u> rite transaction.	4	4
t _{RESET} - Figure 21 (a)	Length of <u>R</u> ESET packets to cause RDRAM to reset.	800 ns	—
t _{CKE} - Figure 21 (b)	Start of <u>C</u> KE packet to start of REQ packet for Suspend-to-Enable.	4	7
t _{PWRUP} - Figure 21 (c)	Length of <u>P</u> WRUP packets to cause Powerdown-to-Enable.	8	8
t _{WREG} - Figure 14 (b)	End of <u>D</u> IN packet for <u>W</u> REG transaction to start of next REQ packet.	16	—

Notes: All units are t_{CYCLE} when not mentioned

a. For READ, WRITE commands

b. For ACTV/READ, ACTV/WRITE, PRE/ACTV/READ, PRE/ACTV/WRITE commands

TIMING WAVEFORM

RSL Rise/Fall Timing

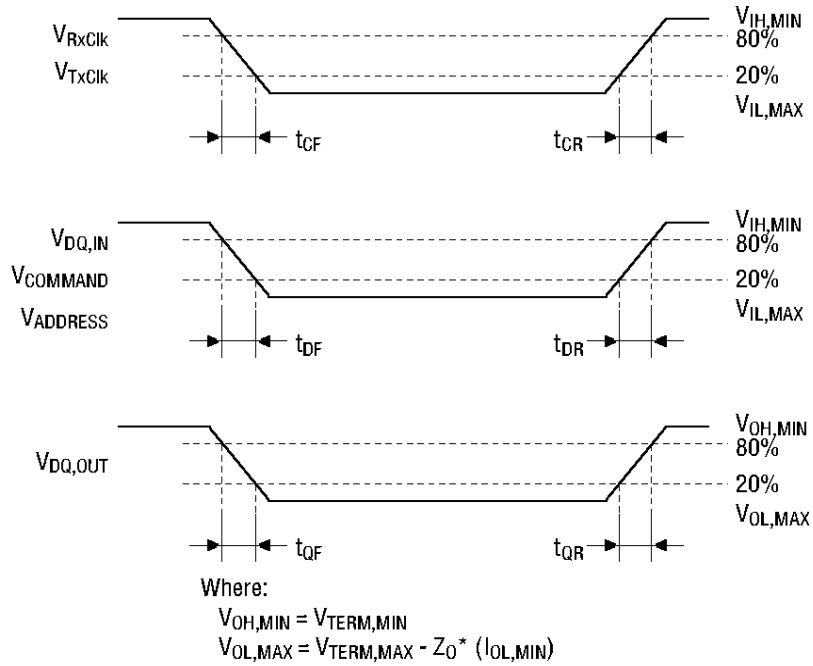

RSL Clock Timing

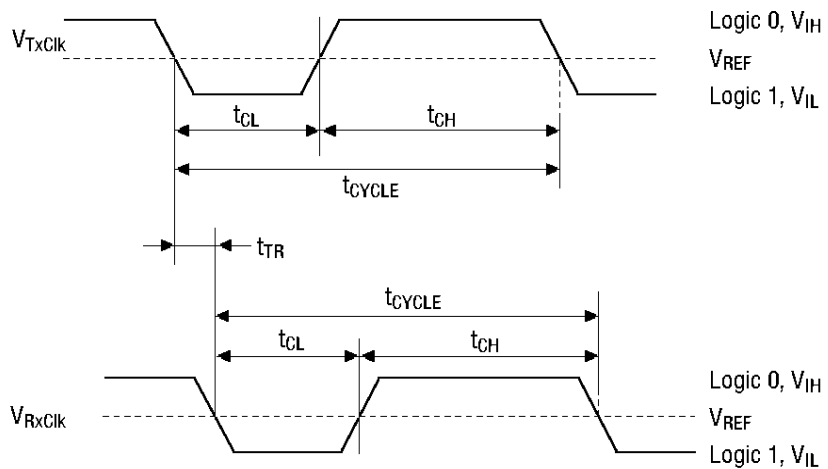

RSL Input (Receive) Timing

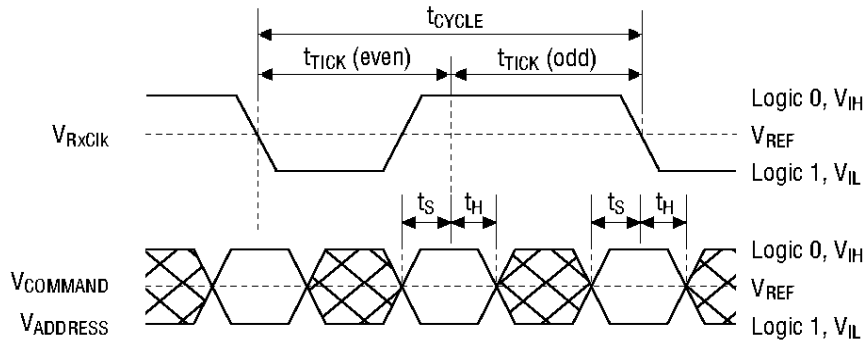

RSL Output (Transmit) Timing

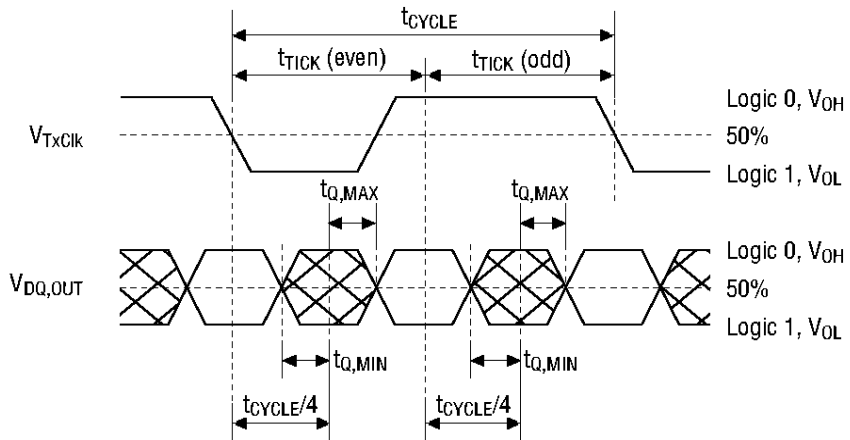

SIN/SOUT Timing

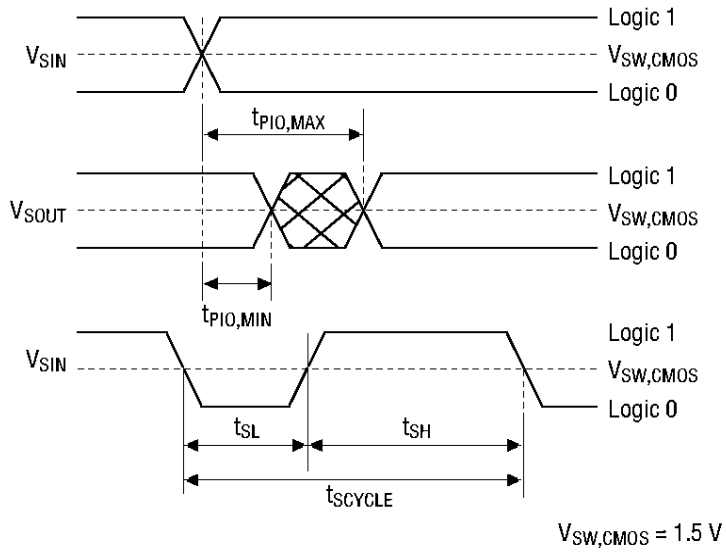

PACKAGE DIMENSIONS

(Unit : mm)

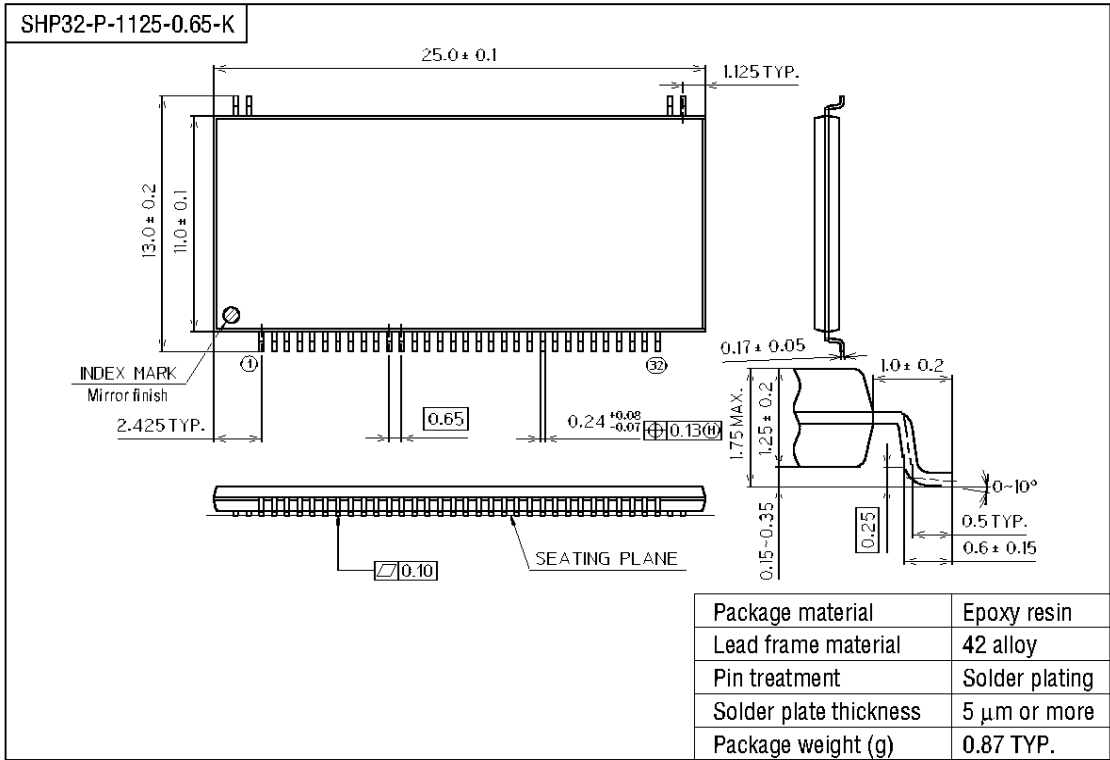

Notes for Mounting the Surface Mount Type Package

The SOP, QFP, TSOP, SOJ, QFJ (PLCC), SHP and BGA are surface mount type packages, which are very susceptible to heat in reflow mounting and humidity absorbed in storage. Therefore, before you perform reflow mounting, contact Oki's responsible sales person for the product name, package name, pin number, package code and desired mounting conditions (reflow method, temperature and times). See also the PACKAGE INFORMATION DATA BOOK for thermal resistances θ_{jc} and θ_{ja} .