



Dual Retriggerable Monostable Multivibrator (with Clear)

ELECTRICALLY TESTED PER:
MIL-M-38510/31401

This DC triggered multivibrator features pulse width control by three methods. The basic pulse width is programmed by selection of external resistance and capacitance values. The 'LS123 has an internal timing resistor that allows the circuit to be used with only an external capacitor. Once triggered, the basic pulse width may be extended by retriggering the gated low-level-active (A) or high-level-active (B) inputs, or be reduced by use of the overriding clear.

The 'LS123 has a Schmitt trigger input to ensure jitter-free triggering from the B input with transition rates as slow as 0.1 millivolt per nanosecond.

- Overriding Clear Terminates Output Pulse
- Compensated for V_{CC} and Temperature Variations
- DC Triggered from Active-High or Active-Low Gated Logic Inputs
- Retriggerable for Very Long Output Pulses, up to 100% Duty Cycle

LOGIC DIAGRAM

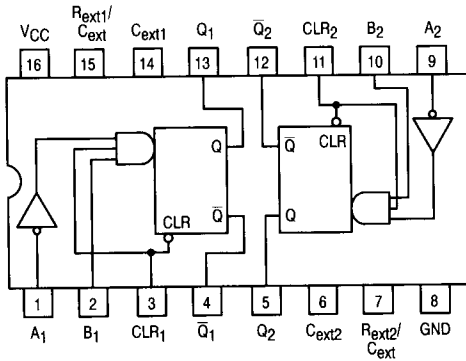

(SEE NOTES 1 THRU 3)

NOTES:

1. An external timing capacitor may be connected between C_{ext} and R_{ext}/C_{ext} (positive).
2. For improved pulse width accuracy connect an external resistor between R_{ext}/C_{ext} and V_{CC} .
3. To obtain variable pulse widths, connect an external variable resistance between R_{ext}/C_{ext} and V_{CC} .

Military 54LS123



AVAILABLE AS:

- 1) JAN: JM38510/31401BXA
- 2) SMD: 7603901
- 3) 883: 54LS123/BXAJC

X = CASE OUTLINE AS FOLLOWS:
PACKAGE: CERDIP: E
CERFLAT: F
LCC: 2

THE LETTER "M" APPEARS BEFORE THE / ON LCC.

PIN ASSIGNMENTS

FUNCT.	DIL 620-09	FLATS 650-05	LCC 756A-02	BURN-IN (COND. A)
A ₁	1	1	2	VCC
B ₁	2	2	3	VCC
CLR ₁	3	3	4	GND
Q ₁	4	4	5	VCC
Q ₂	5	5	7	OPEN
C _{ext2}	6	6	8	OPEN
R _{ext2}	7	7	9	GND
GND	8	8	10	GND
A ₂	9	9	12	VCC
B ₂	10	10	13	VCC
CLR ₂	11	11	14	GND
Q ₂	12	12	15	VCC
Q ₁	13	13	17	OPEN
C _{ext1}	14	14	18	OPEN
R _{ext1}	15	15	19	GND
VCC	16	16	20	VCC

BURN-IN CONDITIONS:
 $V_{CC} = 5.0 \text{ V MIN}/6.0 \text{ V MAX}$

'LS123 FUNCTION TABLE

	Inputs		Outputs	
CLR	A	B	Q	Q̄
L	X	X	L	H
X	H	X	L	H
X	X	L	L	H
H	L	↑	⌋	⌋
H	↓	H	⌋	⌋
↑	L	H	⌋	⌋



TYPICAL APPLICATION DATA

The output pulse t_p is a function of the external components, C_{ext} and R_{ext} or C_{ext} and R_{int} on the 'LS122. For values of $C_{ext} \geq 1000$ pF, the output pulse at $V_{CC} = 5.0$ V and $V_{RC} = 5.0$ V is given by $t_p = K R_{ext}/C_{ext}$ where K is nominally 0.45.

If C_{ext} is in pF and R_{ext} is in k Ω then t_p is in nanoseconds.

The C_{ext} terminal of the 'LS122 and 'LS123 is an internal connection to ground, however for the best system performance C_{ext} should be hardwired to ground.

Care should be taken to keep R_{ext} and C_{ext} as close to the monostable as possible with a minimum amount of inductance between the R_{ext}/C_{ext} junction and the R_{ext}/C_{ext} pin. Good groundplane and adequate bypassing should be designed into the system for optimum performance to ensure that no false triggering occurs.

It should be noted that the C_{ext} pin is internally connected to ground on the 'LS122 and 'LS123, but not on the 'LS221. Therefore, if C_{ext} is hardwired externally to ground, substitution of a 'LS221 onto a 'LS123 socket will cause the 'LS221 to become non-functional.

The switching diode is not needed for electrolytic capacitance application and should not be used on the 'LS122 and 'LS123.

To find the value of K for $C_{ext} \geq 1000$ pF, refer to Figure 4. Variations on V_{CC} or V_{RC} can cause the value of K to change, as can the temperature of the 'LS123, 'LS122. Figures 5 and 6 show the behavior of the circuit shown in Figures 1 and 2 if separate power supplies are used for V_{CC} and V_{RC} . If V_{CC} is

tied to V_{RC} , Figure 7 shows how K will vary with V_{CC} and temperature. Remember, the changes in R_{ext} and C_{ext} with temperature are not calculated and included in the graph.

As long as $C_{ext} \geq 1000$ pF and 5.0 k $\leq R_{ext} \leq 160$ k (54LS122/123), the change in K with respect to R_{ext} is negligible.

If $C_{ext} \leq 1000$ pF the graph shown on Figure 8 can be used to determine the output pulse width. Figure 9 shows how K will change for $C_{ext} \leq 1000$ pF if V_{CC} and V_{RC} are connected to the same power supply. The pulse width t_p in nanoseconds is approximated by

$$t_p = 6.0 + 0.05 C_{ext} (\text{pF}) + 0.45 R_{ext} (\text{k}\Omega) \\ C_{ext} + 11.6 R_{ext}$$

In order to trim the output pulse width, it is necessary to include a variable resistor between V_{CC} and the R_{ext}/C_{ext} pin or between V_{CC} and the R_{ext} pin of the 'LS122. Figures 10, 11 and 12 show how it can be done. R_{ext} remote should be kept as close to the monostable as possible.

Retriggering of the part, as shown in Figure 3, must not occur before C_{ext} is discharged or the retrigger will not have any effect. The discharge time of C_{ext} in nanoseconds is guaranteed to be less than $0.22 C_{ext}$ (pF) and is typically $0.05 C_{ext}$ (pF).

For the smallest possible deviation in output pulse widths from various devices, it is suggested that C_{ext} be kept ≥ 1000 pF.

5

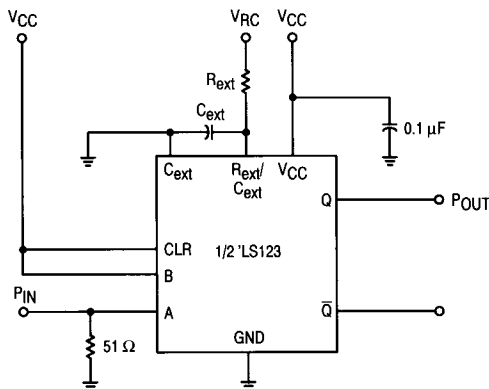

Figure 1

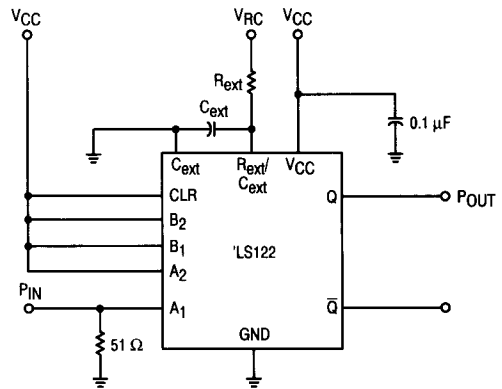
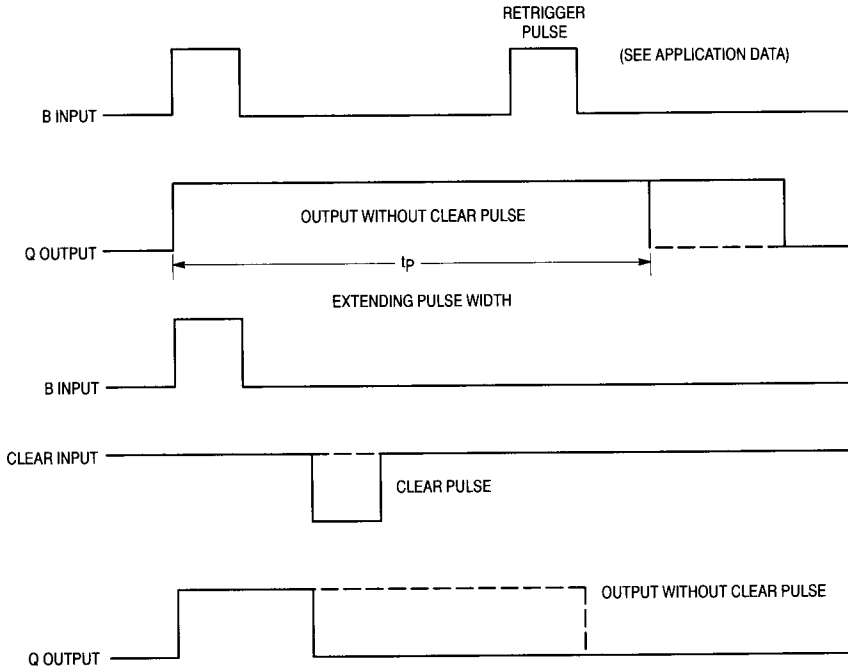

Figure 2

54LS123

WAVEFORMS



Overriding The Output Pulse

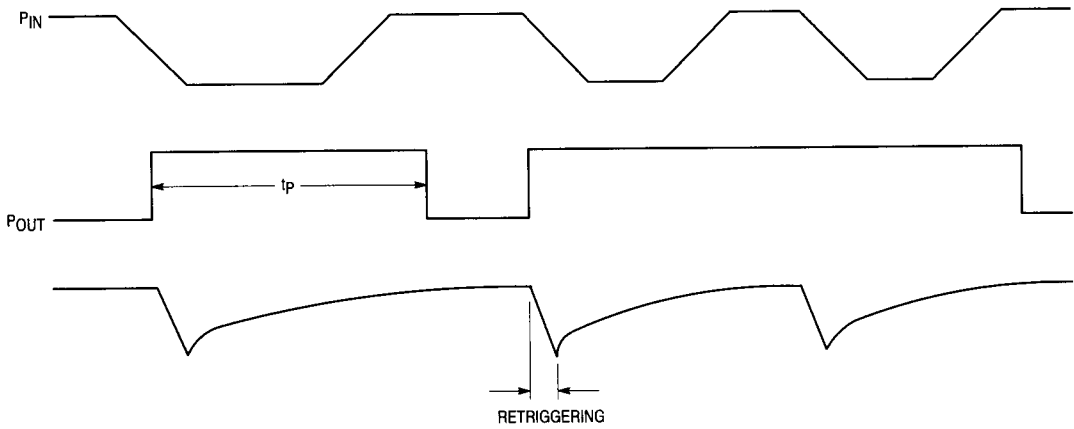

Figure 3

54LS123

EXTERNAL CAPACITANCE, C_{ext} (μF)

$5 k \leq R_{ext} \leq 260 k$



Figure 4

5

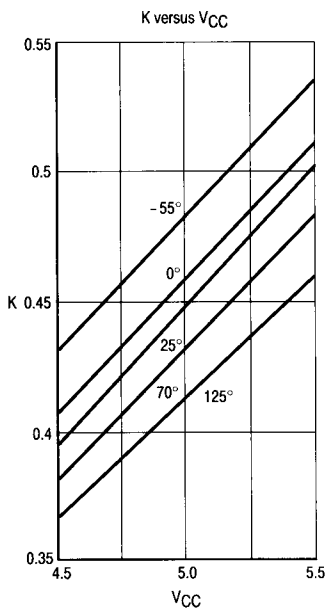

Figure 5

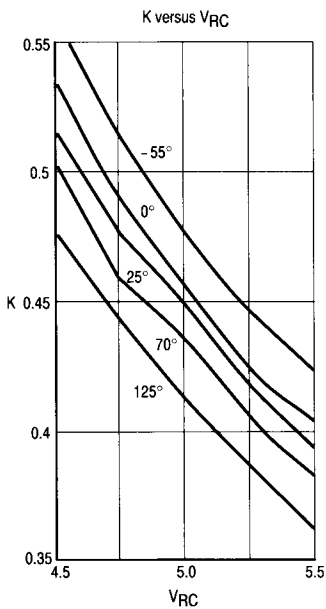

Figure 6

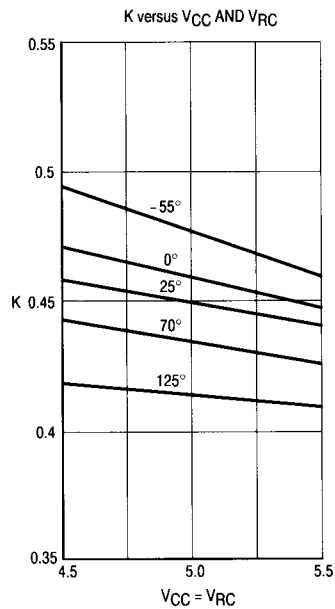

Figure 7

54LS123

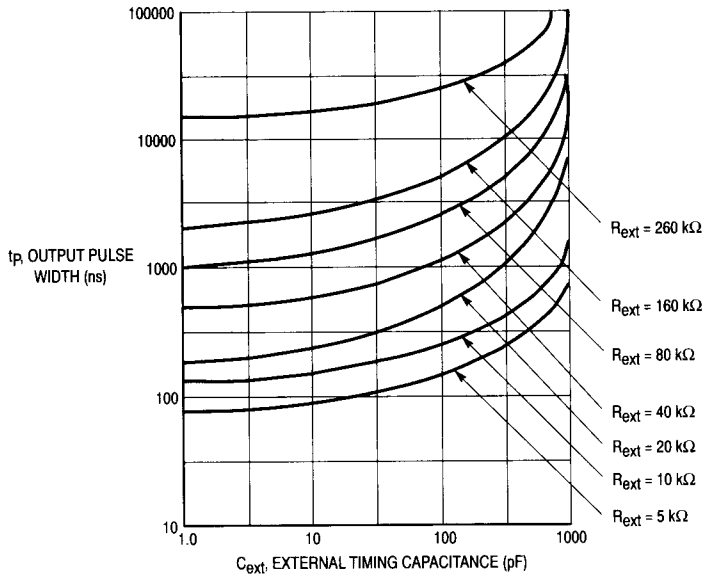

Figure 8

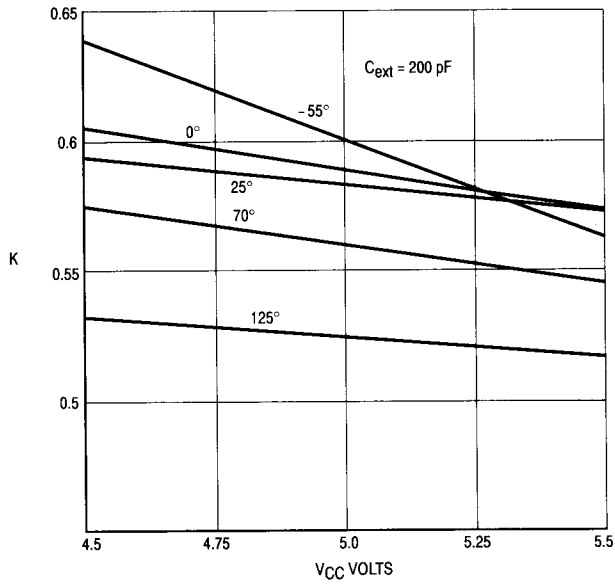

Figure 9

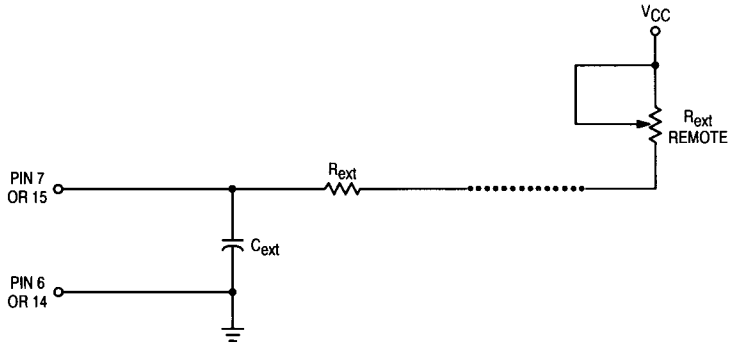

Figure 10. 'LS123 Remote Trimming Circuit

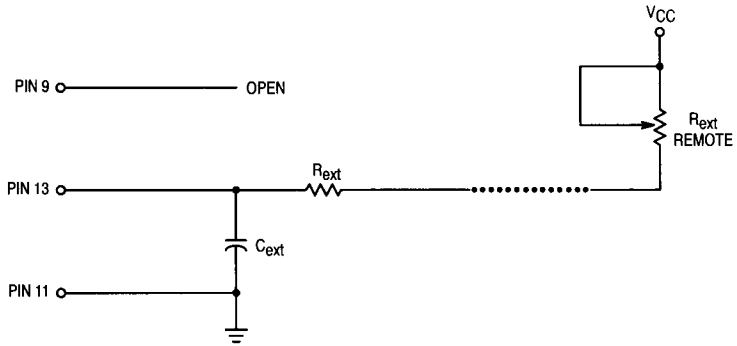

Figure 11. 'LS122 Remote Trimming Circuit Without R_{ext}

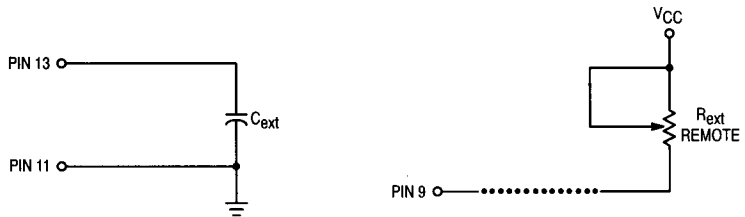
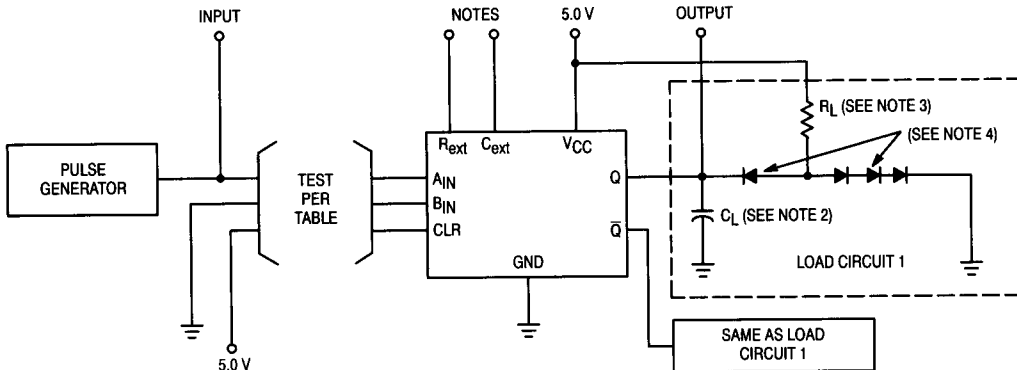

Figure 12. 'LS122 Remote Trimming Circuit With R_{INT}

5

54LS123

LOAD FOR OUTPUT UNDER TEST



SWITCHING WAVEFORMS

t_{PLH1} and t_p Waveforms

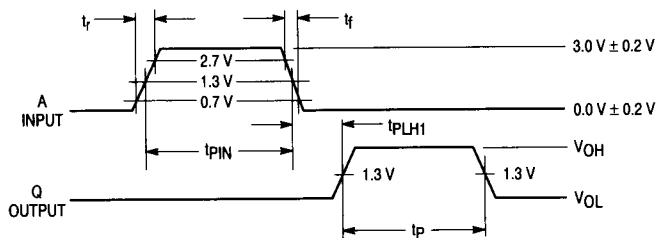

t_{PLH2} and t_p Waveforms

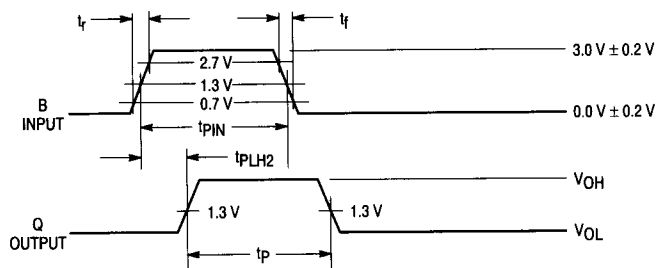

NOTES:

- Pulse generator has the following characteristics:
 $PRR \leq 1.0$ MHz, $t_r \leq 15$ ns, $t_f \leq 6.0$ ns, $t_{PIN} \geq 40$ ns and $Z_{OUT} = 50 \Omega$.
- $C_L = 50$ pF $\pm 10\%$, including scope probe, wiring and stray capacitance without package in test fixture.
- $R_L = 2.0$ k Ω $\pm 5.0\%$.
- All diodes are 1N3064 or 1N916 or equivalent.
- The limits specified for $C_L = 15$ pF are guaranteed but not tested.
- t_{setup} (max) shall be $\leq 50\%$ of the typical output pulse width for the actual C_{ext} used.
- C_{ext} connected to R_{ext}/C_{ext} through a $1,000$ pF $\pm 10\%$ capacitor.
- R_{ext}/C_{ext} connected to V_{CC} through a 5.0 k Ω $\pm 10\%$ resistor.
- R_{ext}/C_{ext} connected to V_{CC} through a 5.0 k Ω to 180 k Ω resistor, and C_{ext} connected to R_{ext}/C_{ext} through a $\leq 1,000$ pF capacitor.
- R_{ext}/C_{ext} connected to V_{CC} through a 10 k Ω $\pm 10\%$ resistor.
- C_{ext} connected to R_{ext}/C_{ext} through a ≥ 45 pF capacitor, R_{ext}/C_{ext} connected to V_{CC} through a 10 k Ω $\pm 10\%$ resistor.

SWITCHING WAVEFORMS

t_{PLH1} Waveforms

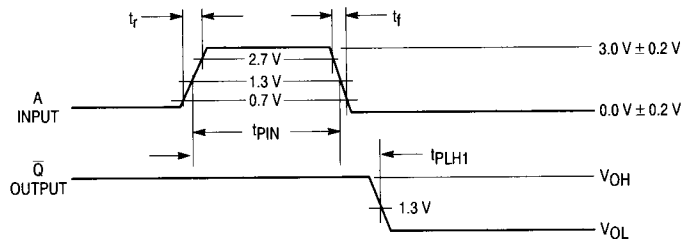

t_{PLH2} Waveforms

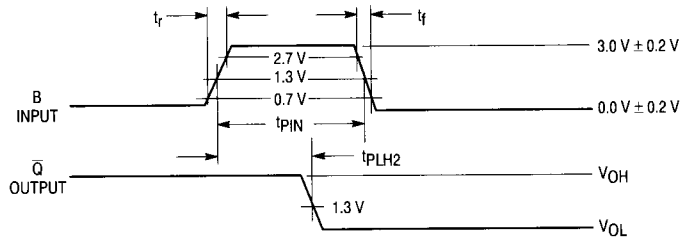

54LS123

Symbol	Parameter	Limits						Unit	Test Condition (Unless Otherwise Specified)
		+ 25°C		+ 125°C		- 55°C			
		Subgroup 1		Subgroup 2		Subgroup 3			
		Min	Max	Min	Max	Min	Max		
V _{OH}	Logical "1" Output Voltage	2.5		2.5		2.5		V	V _{CC} = 4.5 V, I _{OH} = -0.4 mA, V _{IH} = 2.0 V, other input = 0.7 V, R _{ext} = GND or open.
V _{OL}	Logical "0" Output Voltage		0.4		0.4		0.4	V	V _{CC} = 4.5 V, I _{OH} = 4.0 mA, V _{IH} = 2.0 V, other input = 0.7 V, R _{ext} = GND or open.
V _{IC}	Input Clamping Voltage		-1.5					V	V _{CC} = 4.5 V, I _{IN} = -18 mA, other inputs are open.
I _{IH}	Logical "1" Input Current		20		20		20	μA	V _{CC} = 5.5 V, V _{IH} = 2.7 V, other input is GND.
I _{IHH}	Logical "1" Input Current		100		100		100	μA	V _{CC} = 5.5 V, V _{IHH} = 5.5 V, other input is GND.
I _{IL}	Logical "0" Input Current	-120	-360	-120	-360	-120	-360	μA	V _{CC} = 5.5 V, V _{IN} = 0.4 V, other inputs = 4.5 V.
I _{OS}	Output Short Circuit Current	-15	-100	-15	-100	-15	-100	mA	V _{CC} = 5.5 V, V _{IN} = 4.5 V or GND, V _{OUT} = GND.
I _{CC}	Power Supply Current		20		20		20	mA	V _{CC} = 5.5 V, V _{IN} = 5.5 V all inputs, R _{ext} = 0.7 V.
V _{IH}	Logical "1" Input Voltage	2.0		2.0		2.0		V	V _{CC} = 4.5 V.
V _{IL}	Logical "0" Input Voltage		0.7		0.7		0.7	V	V _{CC} = 4.5 V.
	Functional Tests	Subgroup 7		Subgroup 8A		Subgroup 8B			per Truth Table with V _{CC} = 5.0 V, V _{INL} = 0.4 V, and V _{INH} = 2.5 V.

NOTE:

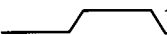
1. Apply input pulse:  2.5 V minimum to 5.5 V maximum
0.0 V

54LS123

Symbol	Parameter	Limits						Unit	Test Condition (Unless Otherwise Specified)
		+ 25°C		+ 125°C		- 55°C			
		Subgroup 9		Subgroup 10		Subgroup 11			
		Min	Max	Min	Max	Min	Max		
t _{PHL1} t _{PHL1}	Propagation Delay /Data-Output Output High-Low	5.0 —	50 45	5.0 —	75 70	5.0 —	75 70	ns	V _{CC} = 5.0 V, C _L = 50 pF, R _L = 2.0 kΩ. V _{CC} = 5.0 V, C _L = 15 pF, R _L = 2.0 kΩ. R _{ext} = 5.0 kΩ.
t _{PLH1} t _{PLH1}	Propagation Delay /Data-Output Output Low-High	5.0 —	38 33	5.0 —	57 52	5.0 —	57 52	ns	V _{CC} = 5.0 V, C _L = 50 pF, R _L = 2.0 kΩ. V _{CC} = 5.0 V, C _L = 15 pF, R _L = 2.0 kΩ. R _{ext} = 5.0 kΩ.
t _{PHL2} t _{PHL2}	Propagation Delay /Data-Output Output High-Low	5.0 —	61 56	5.0 —	92 87	5.0 —	92 87	ns	V _{CC} = 5.0 V, C _L = 50 pF, R _L = 2.0 kΩ. V _{CC} = 5.0 V, C _L = 15 pF, R _L = 2.0 kΩ. R _{ext} = 5.0 kΩ.
t _{PLH2} t _{PLH2}	Propagation Delay /Data-Output Output Low-High	5.0 —	49 44	5.0 —	74 69	5.0 —	74 69	ns	V _{CC} = 5.0 V, C _L = 50 pF, R _L = 2.0 kΩ. V _{CC} = 5.0 V, C _L = 15 pF, R _L = 2.0 kΩ. R _{ext} = 5.0 kΩ.
t _{PHL3} t _{PHL3}	Propagation Delay /Data-Output Output High-Low	5.0 —	32 27	5.0 —	48 43	5.0 —	48 43	ns	V _{CC} = 5.0 V, C _L = 50 pF, R _L = 2.0 kΩ. V _{CC} = 5.0 V, C _L = 15 pF, R _L = 2.0 kΩ. R _{ext} = 5.0 kΩ.
t _{PLH3} t _{PLH3}	Propagation Delay /Data-Output Output Low-High	5.0 —	50 45	5.0 —	75 70	5.0 —	75 70	ns	V _{CC} = 5.0 V, C _L = 50 pF, R _L = 2.0 kΩ. V _{CC} = 5.0 V, C _L = 15 pF, R _L = 2.0 kΩ. R _{ext} = 5.0 kΩ.
t _{p(min)}	A or B to Q		205 200		308	5.0		ns	V _{CC} = 5.0 V, C _L = 50 pF, R _L = 2.0 kΩ. V _{CC} = 5.0 V, C _L = 15 pF, R _L = 2.0 kΩ. R _{ext} = 5.0 kΩ.
t _{pQ}	A to B to Q	3.5 4.0	6.0 6.0	3.0 —	6.25 —	3.0 —	6.25 —	ns	V _{CC} = 5.0 V, C _L = 50 pF, R _L = 2.0 kΩ. V _{CC} = 5.0 V, C _L = 15 pF, R _L = 2.0 kΩ. R _{ext} = 10 kΩ, C _{ext} = 1000 pF.