



SANYO Semiconductors

DATA SHEET

LA6546H

Monolithic Linear IC
For Compact Disk
Four-Channel Bridge (BTL) Driver

Overview

The LA6546H is a 4-channel bridge (BTL) driver for CD players.

Functions

- Bridge-connection (BTL) power amplifier 4-channel.
- I_O max 700mA
- Operation-amplifier built-in
- MUTE circuit built-in (operable for all channels)
- 5V power supply built-in (with external PNP output)
- Reset circuit built-in (reset output delay time set with the external capacitor)

Specifications

Maximum Ratings at $T_a = 25^\circ\text{C}$

Parameter	Symbol	Conditions	Ratings	Unit
Supply voltage	V_{CC} max		14	V
Allowable power dissipation	P_d max	Measure with a designated substrate*	2.34	W
Maximum input voltage	V_{INB}		13	V
MUTE pin voltage	V_{MUTE}		13	V
Operating temperature	T_{opr}		-30 to +85	$^\circ\text{C}$
Storage temperature	T_{stg}		-55 to +150	$^\circ\text{C}$

* Specified board size : 76.1×114.3×1.6mm³, glass epoxy.

Recommended Operating Conditions at $T_a = 25^\circ\text{C}$

Parameter	Symbol	Conditions	Ratings	Unit
Operating voltage	V_{CC}		5.6 to 13	V
Reset output source current	I_{ORH}		0 to 200	μA
Reset output sync current	I_{ORL}		0 to 2	mA

■ Any and all SANYO Semiconductor products described or contained herein do not have specifications that can handle applications that require extremely high levels of reliability, such as life-support systems, aircraft's control systems, or other applications whose failure can be reasonably expected to result in serious physical and/or material damage. Consult with your SANYO Semiconductor representative nearest you before using any SANYO Semiconductor products described or contained herein in such applications.

■ SANYO Semiconductor assumes no responsibility for equipment failures that result from using products at values that exceed, even momentarily, rated values (such as maximum ratings, operating condition ranges, or other parameters) listed in products specifications of any and all SANYO Semiconductor products described or contained herein.

SANYO Semiconductor Co., Ltd.

TOKYO OFFICE Tokyo Bldg., 1-10, 1 Chome, Ueno, Taito-ku, TOKYO, 110-8534 JAPAN

Electrical Characteristics at Ta = 25°C, VCC = 8V, VREF = 2.5V

Parameter	Symbol	Conditions	Ratings			Unit
			min	typ	max	
Overall						
No-load current drain 1	ICC1	All amp outputs ON (MUTE HI) *1		20	40	mA
No-load current drain 2	ICC2	All amp outputs OFF (MUTE LOW) *1		15	35	mA
Output offset voltage 1	VOF1	CH1 (VO1+ and VO1-), CH2 (VO2+ and VO2-)	-50		50	mV
Output offset voltage 2	VOF1	CH3 (VO3+ and VO3-), CH4 (VO4+ and VO4-)	-50		50	mV
VREF input voltage range	IBIN		1.5		VCC-1.5	V
Output voltage	VO	RL = 8.0Ω *1	4.0	4.7		V
Closed-circuit voltage gain	VG			9		dB
Slew rate	SR			0.15		V/μs
MUTE ON voltage	VMUTE			1.2		V
5V power block (PNP Tr 2SB632K used externally)						
Output voltage	VOU1	IO = 200mA	4.75	5.0	5.25	V
Line regulation	ΔVOLN1	5.6V ≤ VIN1 ≤ 12V		20	100	mV
Load regulation	ΔVOLD1	5mA ≤ IO ≤ 200mA		50	150	mV
Reset block						
H reset output voltage	VORH	IORH = 200μA, CD Pin open	4.73	4.98	5.23	V
L reset output voltage	VORL	IORL = 2mA, CD-GND short-circuited		100	200	mV
Reset threshold voltage	VRT	*3		4.3		V
Reset hysteresis voltage	VHYS	*4	40	100	200	mV
Reset output delay time	td	Cd = 0.1μF		10		ms
Pre-amplifier block						
Output offset voltage	VOFF-OP		-7	0	7	mV
Input voltage range	VIN-OP		1.5		VCC-1.5	V
Output voltage SOURCE	VSOURCE-OP			1.2		V
Output voltage SYNC	VSINK-OP			0.5		V

Note *1 : Voltage across both ends of 8Ω load inserted between outputs. Input = H or L.

The output is in the saturation condition.

*2 : The output is ON with MUTE = H and OFF with MUTE = L. MUTE is operable for all channels.

With MUTE = L, the output is OFF and the impedance is HI.

*3 : 5V supply voltage when the reset output is LOW.

*4 : Potential difference of 5V supply voltage between the reset output at LOW and at HI.

Hysteresis width.

Package Dimensions

unit : mm (typ)

3233B

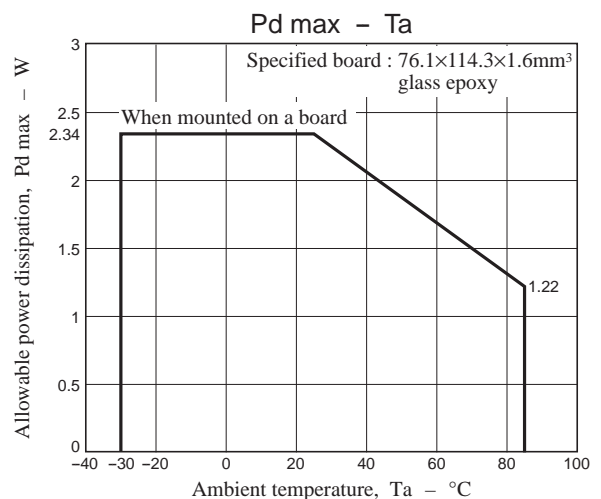
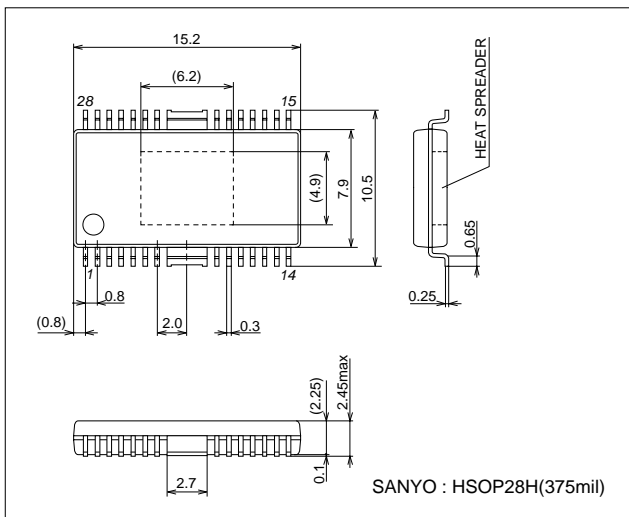

Block Diagram and Sample Application Circuit

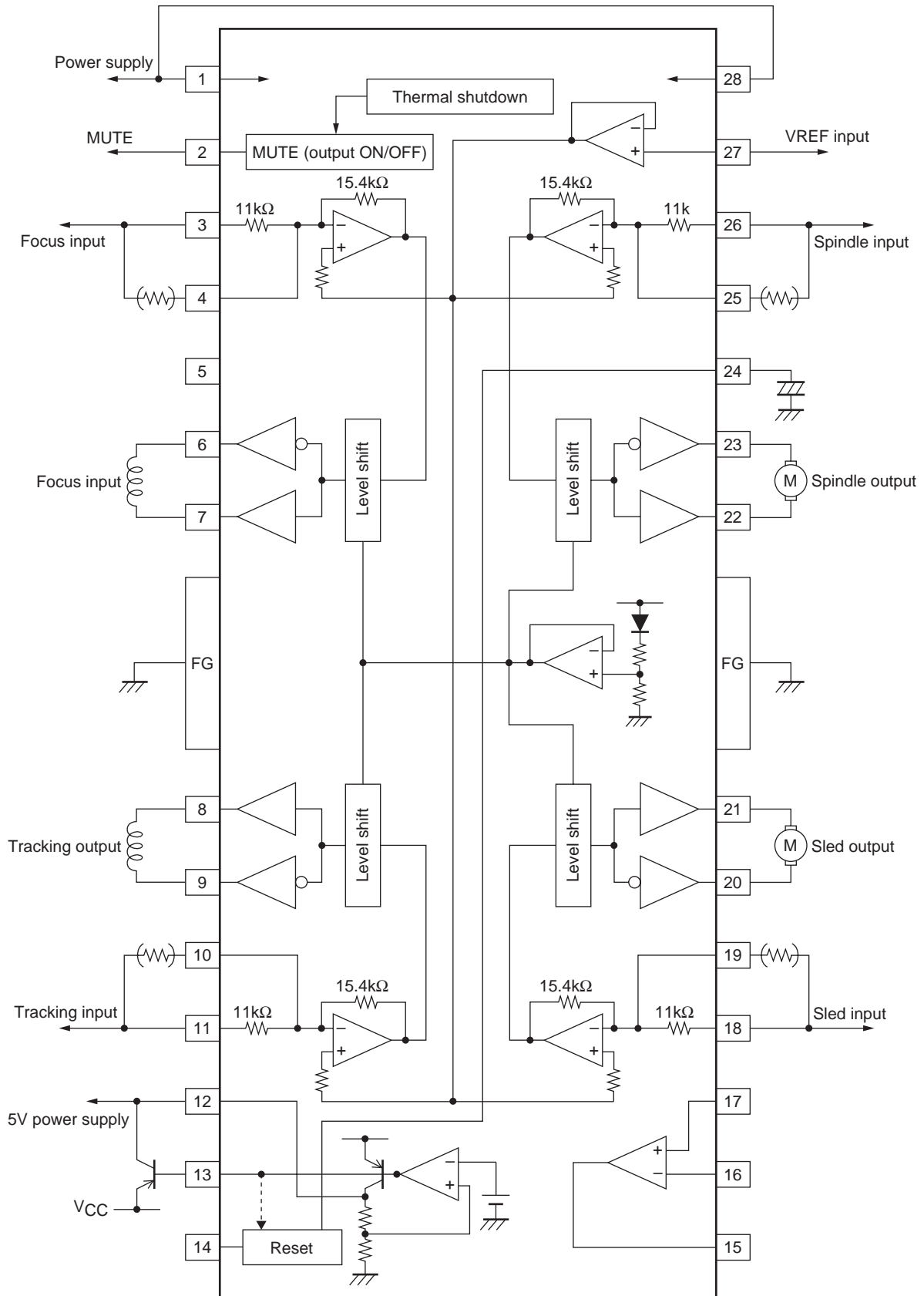

Pin Functions

Pin No.	Symbol	Pin descriptions
1	V _{CC1}	Substrate (Lowest potential)
2	MUTE	Output ON/OFF. Operable for all channels
3	V _{IN1}	CH1 input pin
4	VG1	CH1 input pin (for gain control)
5	(NC)	Do not use
6	V _{O1+}	CH1 output pin (+)
7	V _{O1-}	CH1 output pin (-)
8	V _{O2-}	CH2 output pin (-)
9	V _{O2+}	CH2 output pin (+)
10	VG2	CH2 input pin (for gain control)
11	V _{IN2}	CH2 input pin
12	REG-OUT	Connect collector of the external transistor (PNP), 5V power output
13	REG-IN	Connect base of the external transistor (PNP)
14	$\overline{\text{RES}}$	Reset output
15	V _{OUT}	OP-AMP output pin
16	V _{IN-}	OP-AMP input pin (-)
17	V _{IN+}	OP-AMP input pin (+)
18	V _{IN3}	CH3 input pin
19	VG3	CH3 input pin (for gain control)
20	V _{O3+}	CH3 output pin (+)
21	V _{O3-}	CH3 output pin (-)
22	V _{O4-}	CH4 output pin (-)
23	V _{O4+}	CH4 output pin (+)
24	CD	Reset output delay time setting (with external capacitor)
25	VG4	CH4 input pin (for gain control)
26	V _{IN4}	CH4 input pin
27	VREF	Application of the reference voltage
28	V _{CC2}	Power supply (short-circuit with pin 1)

Note : Set GND (minimum potential) the middle frame and connect both of them.

Pin Description

Pin No.	Symbol	Pin function	Description	Equivalent circuit
3 11 18 26 4 10 19 25	V_{IN1} V_{IN2} V_{IN3} V_{IN4} $VG1$ $VG2$ $VG3$ $VG4$	Input	Each input pin	
6, 7 8, 9 20, 21 22, 23	V_{O1+} , V_{O1-} V_{O2+} , V_{O2-} V_{O3+} , V_{O3-} V_{O4+} , V_{O4-}	Output	Each output pin	
2	MUTE	MUTE	MUTE (output ON/OFF)	

Truth Table

Input	MUTE	CH1		CH2		CH3		CH4	
		V_{O1+}	V_{O1-}	V_{O2+}	V_{O2-}	V_{O3+}	V_{O3-}	V_{O4+}	V_{O4-}
H	H	H	L	L	H	H	L	L	H
	L	-	-	-	-	-	-	-	-
L	H	L	H	H	L	L	H	H	L
	L	-	-	-	-	-	-	-	-

* - : High-impedance

Gain setting

For gain setting, refer to the block diagram. When setting the gain with the VG* terminal, the total gain has more or less temperature characteristics due to difference in temperature characteristics between internal and external resistors. Use the V_{IN}* terminal to set the gain.

Reset operation

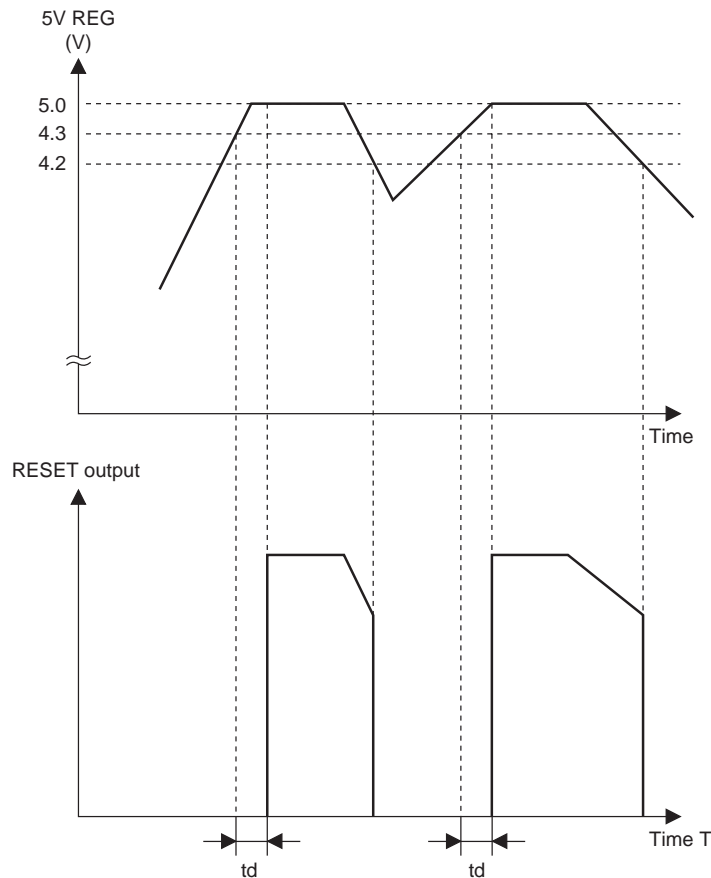

- Specifications of any and all SANYO Semiconductor products described or contained herein stipulate the performance, characteristics, and functions of the described products in the independent state, and are not guarantees of the performance, characteristics, and functions of the described products as mounted in the customer's products or equipment. To verify symptoms and states that cannot be evaluated in an independent device, the customer should always evaluate and test devices mounted in the customer's products or equipment.
- SANYO Semiconductor Co., Ltd. strives to supply high-quality high-reliability products. However, any and all semiconductor products fail with some probability. It is possible that these probabilistic failures could give rise to accidents or events that could endanger human lives, that could give rise to smoke or fire, or that could cause damage to other property. When designing equipment, adopt safety measures so that these kinds of accidents or events cannot occur. Such measures include but are not limited to protective circuits and error prevention circuits for safe design, redundant design, and structural design.
- In the event that any or all SANYO Semiconductor products (including technical data, services) described or contained herein are controlled under any of applicable local export control laws and regulations, such products must not be exported without obtaining the export license from the authorities concerned in accordance with the above law.
- No part of this publication may be reproduced or transmitted in any form or by any means, electronic or mechanical, including photocopying and recording, or any information storage or retrieval system, or otherwise, without the prior written permission of SANYO Semiconductor Co., Ltd.
- Any and all information described or contained herein are subject to change without notice due to product/technology improvement, etc. When designing equipment, refer to the "Delivery Specification" for the SANYO Semiconductor product that you intend to use.
- Information (including circuit diagrams and circuit parameters) herein is for example only; it is not guaranteed for volume production. SANYO Semiconductor believes information herein is accurate and reliable, but no guarantees are made or implied regarding its use or any infringements of intellectual property rights or other rights of third parties.

This catalog provides information as of December, 2006. Specifications and information herein are subject to change without notice.