

DATE	SYM	REVISION	RECORD	AUTH.	DR.	CK.
					NT	

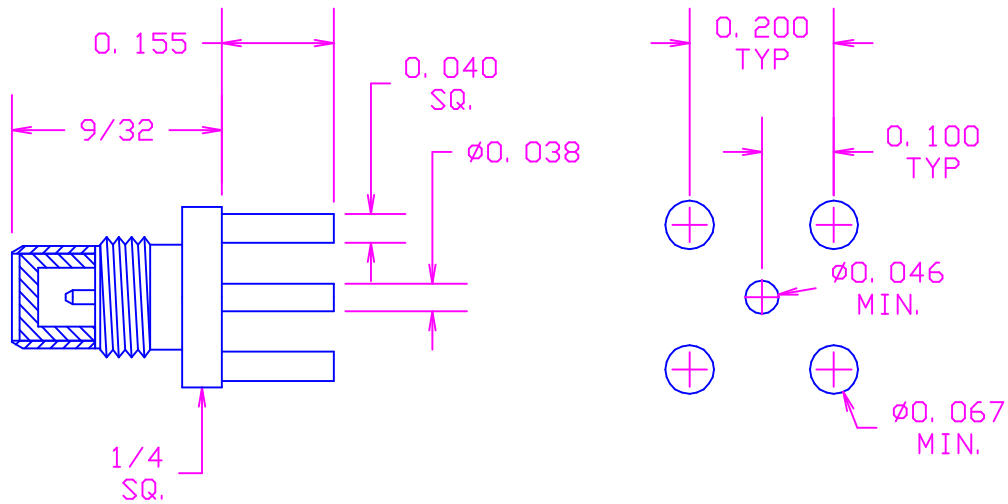

MATERIAL: BODY AND MALE CONTACT- BRASS PER  
 QQ-B-626, ALLOY 360, 1/2 HARD  
 INSULATION- TFE FLUOROCARBON PER L-P-403  
 FINISH: CENTER CONTACT- .00005"MIN. GOLD PER  
 MIL-G-45204B TYPE I, GRADE C, CLASS 2,  
 OVER .000005"MIN. GOLD PER MIL-G-45204B  
 TYPE I, GRADE A, OVER .0001"MIN. COPPER  
 PER MIL-C-14550 CLASS 4  
 OTHER METAL PARTS- GOLD PLATED

ACTUAL SIZE



TOLERANCES	CONCORD ELECTRONICS CORPORATION		
DECIMAL ± .010	P/N	SCALE	30 GREAT JONES ST. NEW YORK N. Y. 10012
FRACTIONAL ± 1/64	TITLE JACK STRAIGHT		
ANGULAR ± -	DATE 11-5-97	DRAWING NUMBER 800-1018	