

FEATURES

- Function, Pinout and Drive Compatible with the FCT and F Logic
- FCT-C speed at 5.2ns max. (Com'I)
FCT-A speed at 7.2ns max. (Com'I)
- Reduced V_{OH} (typically = 3.3V) versions of Equivalent FCT functions
- Edge-rate Control Circuitry for Significantly Improved Noise Characteristics
- Power-off disable feature
- Matched Rise and Fall times
- Fully Compatible with TTL Input and Output Logic Levels
- 64 mA Sink Current (Com'I), 32 mA (Mil)
15 mA Source Current (Com'I), 12 mA (Mil)
- Clock Enable for Address and Data Synchronization Application
- Eight Edge-Triggered D Flip-Flops

2
DESCRIPTION

The 'FCT377T have eight edge-triggered, D-type flip-flops with individual D inputs and O outputs. The common buffered clock (CP) input loads all flip-flops simultaneously when the Clock Enable (\overline{CE}) is LOW. The register is fully edge-triggered. The state of each D input one set-up time

before the LOW-to-HIGH clock transition, is transferred to the corresponding flip-flop's O output. The \overline{CE} input must be stable only one set-up time prior to the LOW-to-HIGH clock transition for predictable operation.

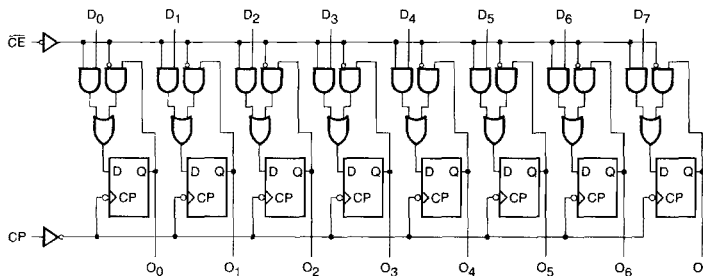
FUNCTIONAL BLOCK DIAGRAM

1735 01

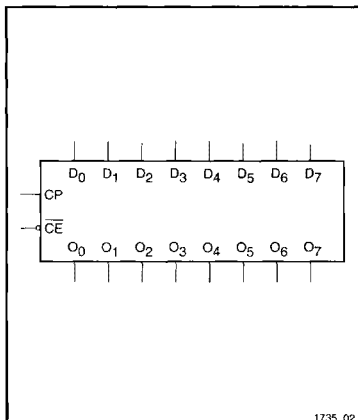
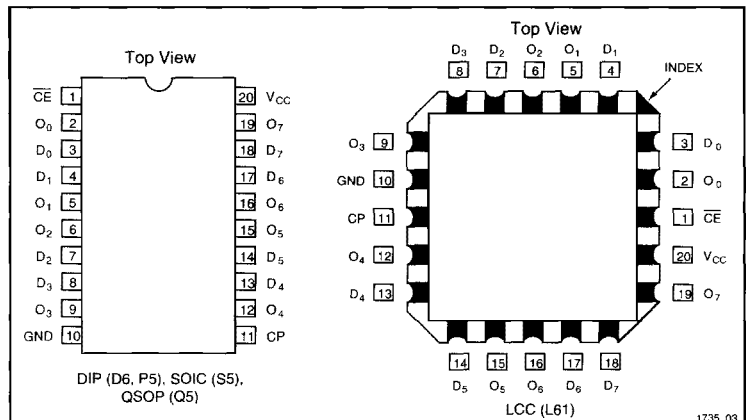
LOGIC SYMBOL

PIN CONFIGURATIONS

ABSOLUTE MAXIMUM RATINGS^{1,2}

Symbol	Parameter	Value	Unit
T_{STG}	Storage Temperature	-65 to +150	°C
T_A	Ambient Temperature Under Bias	-65 to +135	°C
V_{CC}	V_{CC} Potential to Ground	-0.5 to +7.0	V
P_T	Power Dissipation	0.5	W

1735 Tbl 01

Notes:

- Operation beyond the limits set forth in the above table may impair the useful life of the device. Unless otherwise noted, these limits are over the operating free-air temperature range.

Symbol	Parameter	Value	Unit
I_{OUTPUT}	Current Applied to Output	120	mA
V_{IN}	Input Voltage	-0.5 to +7.0	V
V_{OUT}	Voltage Applied to Output	-0.5 to +7.0	V

1735 Tbl 02

- Unused inputs must always be connected to an appropriate logic voltage level, preferably either V_{CC} or ground.

RECOMMENDED OPERATING CONDITIONS

Free Air Ambient Temperature	Min	Max
Military	-55°C	+125°C
Commercial	0°C	+70°C

1735 Tbl 03

Supply Voltage (V_{CC})	Min	Max
Military	+4.5V	+5.5V
Commercial	+4.75V	+5.25V

1735 Tbl 04

DC ELECTRICAL CHARACTERISTICS (Over recommended operating conditions)

Symbol	Parameter	Min	Typ ¹	Max	Units	V_{CC}	Conditions
V_{IH}	Input HIGH Voltage	2.0			V		
V_{IL}	Input LOW Voltage			0.8	V		
V_H	Hysteresis		0.2		V		All inputs
V_{IK}	Input Clamp Diode Voltage		-0.7	-1.2	V	MIN	$I_{IN} = -18mA$
V_{OH}	Output HIGH Voltage	Military	2.4	3.3	V	MIN	$I_{OH} = -12mA$
		Commercial	2.4	3.3	V	MIN	$I_{OH} = -15mA$
V_{OL}	Output LOW Voltage	Military		0.3	V	MIN	$I_{OL} = 32mA$
		Commercial		0.3	V	MIN	$I_{OL} = 48mA$
		Commercial		0.3	V	MIN	$I_{OL} = 64mA$
I_I	Input HIGH Current			20	μA	MAX	$V_{IN} = V_{CC}$
I_{IH}	Input HIGH Current			5	μA	MAX	$V_{IN} = 2.7V$
I_{IL}	Input LOW Current			-5	μA	MAX	$V_{IN} = 0.5V$
I_{OS}	Output Short Circuit Current ²	-60	-120	-225	mA	MAX	$V_{OUT} = 0.0V$
C_{IN}	Input Capacitance ³		5	10	pF	MAX	All inputs
C_{OUT}	Output Capacitance ³		9	12	pF	MAX	All outputs
I_{CC}	Quiescent Power Supply Current		0.2	1.5	mA	MAX	$V_{IN} \leq 0.2V$,

1735 Tbl 05

Notes:

- Typical values are at $V_{CC} = 5.0V$, $T_A = +25^\circ C$ ambient.
- Not more than one output should be shorted at a time. Duration of short should not exceed one second. The use of high speed test apparatus and/or sample and hold techniques are preferable in order to minimize internal chip heating and more accurately reflect

operational values. Otherwise prolonged shorting of a high output may raise the chip temperature well above normal and thereby cause invalid readings in other parameter tests. In any sequence of parameter tests, I_{OS} tests should be performed last.

- This parameter is guaranteed but not tested.

DC CHARACTERISTICS (Over recommended operating conditions unless otherwise specified.)

Symbol	Parameter	Typ ¹	Max	Units	Conditions
ΔI_{CC}	Quiescent Power Supply Current (TTL inputs) ²	0.5	2.0	mA	$V_{CC} = \text{MAX}$, $V_{IN} = 3.4V^2$, $f_1 = 0$, Outputs Open
I_{CCD}	Dynamic Power Supply Current ³	0.15	0.25	mA/ MHz	$V_{CC} = \text{MAX}$, One Bit Toggling, 50% Duty Cycle, Outputs Open, $\overline{CE} = \text{GND}$, $V_{IN} \leq 0.2V$ or $V_{IN} \geq V_{CC} - 0.2V$
I_C	Total Power Supply Current ⁵	1.7	4.0	mA	$V_{CC} = \text{MAX}$, $f_0 = 10\text{MHz}$, 50% Duty Cycle, Outputs Open, One Bit Toggling at $f_1 = 5\text{MHz}$, $\overline{CE} = \text{GND}$, $V_{IN} \leq 0.2V$ or $V_{IN} \geq V_{CC} - 0.2V$
		2.2	6.0	mA	$V_{CC} = \text{MAX}$, $f_0 = 10\text{MHz}$, 50% Duty Cycle, Outputs Open, One Bit Toggling at $f_1 = 5\text{MHz}$, $\overline{CE} = \text{GND}$, $V_{IN} = 3.4V$ or $V_{IN} = \text{GND}$
		4.0	7.8 ⁴	mA	$V_{CC} = \text{MAX}$, $f_0 = 10\text{MHz}$, 50% Duty Cycle, Outputs Open, Eight Bits Toggling at $f_1 = 2.5\text{MHz}$, $\overline{CE} = \text{GND}$, $V_{IN} \leq 0.2V$ or $V_{IN} \geq V_{CC} - 0.2V$
		6.2	16.8 ⁴	mA	$V_{CC} = \text{MAX}$, $f_0 = 10\text{MHz}$, 50% Duty Cycle, Outputs Open, Eight Bits Toggling at $f_1 = 2.5\text{MHz}$, $\overline{CE} = \text{GND}$, $V_{IN} = 3.4V$ or $V_{IN} = \text{GND}$

2

Notes:

- Typical values are at $V_{CC} = 5.0V$, $+25^\circ\text{C}$ ambient.
- Per TTL driven input ($V_{IN} = 3.4V$); all other inputs at V_{CC} or GND.
- This parameter is not directly testable, but is derived for use in Total Power Supply calculations.
- Values for these conditions are examples of the I_{CC} formula. These limits are guaranteed but not tested.
- $I_C = I_{\text{QUIESCENT}} + I_{\text{INPUTS}} + I_{\text{DYNAMIC}}$
 $I_C = I_{CC} + \Delta I_{CC} D_H N_T + I_{CCD}(f_0/2 + f_1 N_1)$
 I_{CC} = Quiescent Current with CMOS input levels

ΔI_{CC} = Power Supply Current for a TTL High Input ($V_{IN} = 3.4V$)

D_H = Duty Cycle for TTL Inputs High

N_T = Number of TTL Inputs at D_H

I_{CCD} = Dynamic Current Caused by an Input Transition Pair (HLH or LHL)

f_0 = Clock Frequency for Register Devices (Zero for Non-Register Devices)



f_1 = Input Frequency

N_1 = Number of Inputs at f_1

All currents are in milliamps and all frequencies are in megahertz.

1735 Tbl 06

TRUTH TABLE

Operating Mode	Inputs			Outputs
	CP	\overline{CE}	D	O
Load "1"		l	h	H
Load "0"		l	l	L
Hold (Do Nothing)		h	X	No Change
	X	H	X	No Change

1735 Tbl 07

H = HIGH Voltage Level

h = HIGH Voltage Level one setup time prior to the LOW-to-HIGH Clock Transition

L = LOW Voltage Level

l = LOW Voltage Level one setup time prior to the LOW-to-HIGH Clock Transition

X = Immaterial

 = LOW-to-HIGH Clock Transition

AC CHARACTERISTICS

Symbol	Parameter	'FCT377T				'FCT377AT				'FCT377CT				Units	Fig. No.*
		MIL		COM'L		MIL		COM'L		MIL		COM'L			
		Min. ¹	Max.	Min. ¹	Max.	Min. ¹	Max.	Min. ¹	Max.	Min. ¹	Max.	Min. ¹	Max.		
t_{PLH} t_{PHL}	Propagation Delay Clock to Output	2.0	15.0	2.0	13.0	2.0	8.3	2.0	7.2	2.0	5.5	2.0	5.2	ns	1, 5

1735 Tbl 08

Note:

- Minimum limits are guaranteed but not tested on Propagation Delays.
 - AC Characteristics guaranteed with $C_L = 50\text{pF}$ as shown in Figure 1.
- * See "Parameter Measurement Information" in the General Information Section.

AC OPERATING REQUIREMENTS

Symbol	Parameter	'FCT377T				'FCT377AT				'FCT377CT				Units	Fig. No.*
		MIL		COM'L		MIL		COM'L		MIL		COM'L			
		Min. ¹	Max.	Min. ¹	Max.	Min. ¹	Max.	Min. ¹	Max.	Min. ¹	Max.	Min. ¹	Max.		
$t_s(H)$	Setup Time, HIGH or LOW Data to CP	3.0	—	2.5	—	2.0	—	2.0	—	2.0	—	2.0	—	ns	4
$t_h(H)$ $t_h(L)$	Hold Time, HIGH or LOW Data to CP	2.5	—	2.0	—	1.5	—	1.5	—	1.5	—	1.5	—	ns	4
$t_w(H)$ $t_w(L)$	Setup Time, HIGH or LOW \overline{CE} to CP	4.0	—	4.0	—	3.5	—	3.5	—	3.5	—	3.5	—	ns	5
$t_w(H)$ $t_w(L)$	Hold Time, HIGH or LOW \overline{CE} to CP	1.5	—	1.5	—	1.5	—	1.5	—	1.5	—	1.5	—	ns	6
$t_w(L)$	Clock Pulse Width LOW ²	7.0	—	7.0	—	7.0	—	6.0	—	7.0	—	6.0	—	ns	6

1735 Tbl 09

Notes:

- Minimum limits are guaranteed but not tested on Propagation Delays.
 - With one data channel toggling, $t_w(L) = t_w(H) = 4.0\text{ns}$ and $t_s = t_h = 1.0\text{ns}$.
- * See "Parameter Measurement Information" in the General Information Section.

ORDERING INFORMATION

$\frac{CYxxFCT}{\text{Temp. Class}}$ $\frac{xxxx}{\text{Device type}}$ $\frac{x}{\text{Package}}$ $\frac{x}{\text{Processing}}$

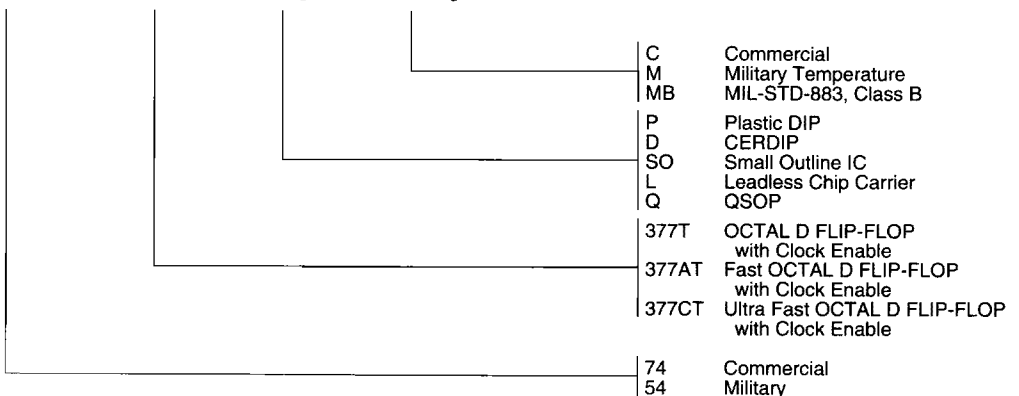

1735 04