

**WDCT Power Amplifier
2400 – 2500 MHz**

**MAAPSS0066
V3**

Features

- Ideal for WDCT Applications
- Saturated Output Power: +25 dBm Typical
- Power Gain: 25 dB Typical
- Low Current: 400 mA at P_{SAT}
- Micro-Amp Shutdown
- Operates from 1.5 V to 4.0 V
- V_{EN} configurable for either 1.7 V or 2.5 V
- Lead-Free 3 mm 12-Lead PQFN Package
- 100% Matte Tin Plating over Copper
- Halogen-Free “Green” Mold Compound
- RoHS* Compliant and 260°C Reflow Compatible

Description

The MAAPSS0066 is a three stage power amplifier designed for Cordless Telephone applications. This power amplifier is packaged in a standard outline, lead-free 3 mm 12-lead PQFN plastic package. The MAAPSS0066 features an integrated bias controller that allows for micro amp shut down current.

Ordering Information¹

Part Number	Package
MAAPSS0066	Bulk Packaging
MAAPSS0066TR-3000	3000 piece reel
MAAPSS0066SMB	Sample Test Board (Includes 5 Samples)

1. Reference Application Note M513 for reel size information.

Absolute Maximum Ratings^{2,3}

Parameter	Absolute Maximum
Input Power	+ 5 dBm
Operating Supply Voltage	+4.0 Volts
Operating Control Voltage	+3.0 Volts
Operating Temperature	-20°C to +85°C
Channel Temperature	+150°C
Storage Temperature	-40°C to +150°C

- Exceeding any one or combination of these limits may cause permanent damage to this device.
- M/A-COM does not recommend sustained operation near these survivability limits.

* Restrictions on Hazardous Substances, European Union Directive 2002/95/EC.

Functional Schematic

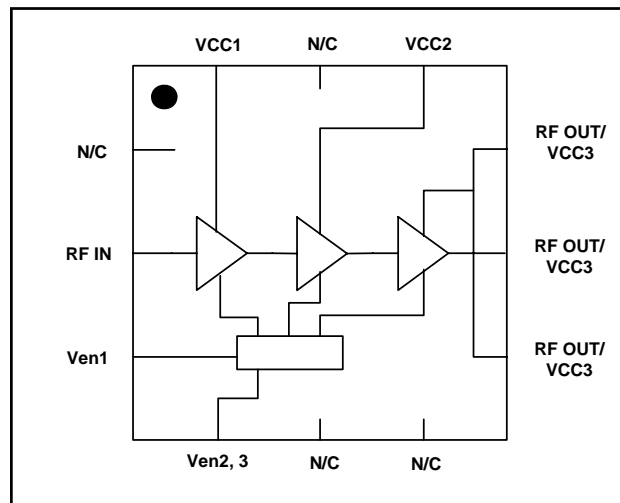

Pin Configuration

Pin No.	Pin Name	Description
1	N/C	No Connection
2	RF _{IN}	RF Input
3	V _{EN1}	Power Enable
4	V _{EN2,3}	Power Enable
5	N/C	No Connection
6	N/C	No Connection
7	RF _{OUT} / V _{CC3}	RF Output, 3rd Stage Supply
8	RF _{OUT} / V _{CC3}	RF Output, 3rd Stage Supply
9	RF _{OUT} / V _{CC3}	RF Output, 3rd Stage Supply
10	V _{CC2}	2nd Stage Supply
11	N/C	No Connection
12	V _{CC1}	1st Stage Supply
Pad ⁴	GND	RF & DC Ground

4. The exposed pad centered on the package bottom must be connected to RF and DC ground.

**WDCT Power Amplifier
2400 – 2500 MHz**

**MAAPSS0066
V3**

Electrical Specifications:

Frequency = 2450 MHz, P_{IN} = -1 to 3 dBm, V_{CC} = 2.4 V, V_{EN} = 2.5 V, T_A = 25 °C, Z₀ = 50Ω

Parameter	Test Conditions	Units	Min.	Typ.	Max
Small Signal Gain	Pin = -20 dBm	dB	—	27	—
Input Return Loss	—	dB	—	15	—
Output Power	—	dBm	23	25	—
Power Flatness	2.0 V < V _{CC} < 3.0 V	dB	—	3	—
PAE	—	%	—	33	—
Current	—	mA	—	400	500
Current, Off	V _{EN} = 0 V	μA	—	3	10
Pdiss	P _{OUT} = 25.0 dBm	W	—	0.6	—
Control Pins	V _{EN, Low}	V	0	—	0.5
	V _{EN, High}	V	2.0	—	2.5
	Current	mA	—	3	4.0
Harmonics	2f	dBc	—	-54	—
	3f	dBc	—	-42	—
Forward Isolation	V _{EN} = 0 V	dB	—	39	—
Duty Cycle	—	%	—	—	100
Stability	+1.5 V < V _{CC} < +3.5 V, P _{IN} = -1 to 3 dBm, VSWR < 6:1 -20°C < T _C < +70°C, RBW = 3 MHz max hold		All spurs < -60 dBc		

Lead-Free 3 mm 12-Lead PQFN†

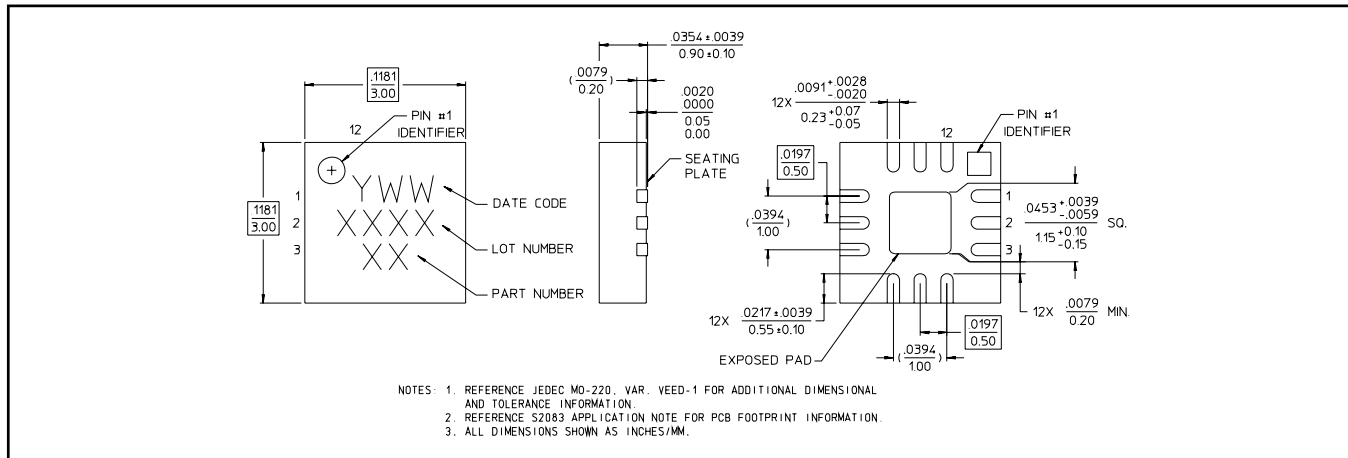

† Reference Application Note M538 for lead-free solder reflow recommendations.
Meets JEDEC moisture sensitivity level 1 requirements.

Operating the MAAPSS0066

The MAAPSS0066 can be damaged by electrostatic discharge (ESD). Use proper ESD control techniques when handling this device. To operate the MAAPSS0066, turn on V_{CC} before V_{EN} for power on and turn off V_{CC} after V_{EN} for shutdown.

2

M/A-COM Inc. and its affiliates reserve the right to make changes to the product(s) or information contained herein without notice. M/A-COM makes no warranty, representation or guarantee regarding the suitability of its products for any particular purpose, nor does M/A-COM assume any liability whatsoever arising out of the use or application of any product(s) or information.

- **North America** Tel: 800.366.2266 / Fax: 978.366.2266
- **Europe** Tel: 44.1908.574.200 / Fax: 44.1908.574.300
- **Asia/Pacific** Tel: 81.44.844.8296 / Fax: 81.44.844.8298

Visit www.macom.com for additional data sheets and product information.

Evaluation Board Schematic

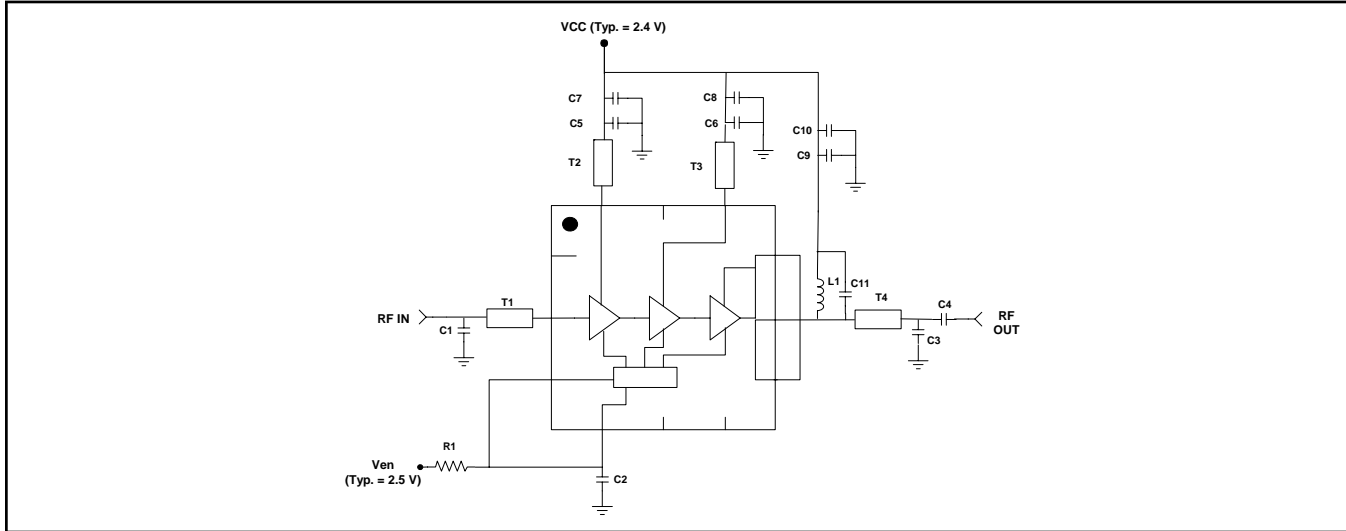

MAAPSS0066 External Parts List

Designator	Value	Footprint	Manufacturer	Part ID
C1, C3	2 pF	0402	Murata	GRM1555C1H2R0CZ01
C2	1 nF	0402	Murata	GRM1555R71H102KA01
C4, C5, C6	47 pF	0402	Murata	GRM1555C1H470JZ01
C7, C8, C9	1 μF	0402	Murata	GRM1555R60J105KE19
C10	4700 pF	0402	Murata	GRM155R71H472KA01D
C11	1 pF	0402	Murata	GRM36C0G010C50
L1	10 nH	0402	Coilcraft	0402CS-10NXJB
R1 (V _{EN} = 2.5 V)	240 Ohm	0402	KOA	RK73B1ET241J
R1 (V _{EN} = 1.7 V)	100 Ohm	0402	KOA	RK73B1ET101J

Transmission Line Dimensions, 0.20 mm thick FR4

Designator	Length (mm) *	Width (mm)
T1	5.20	0.37
T2	1.00	0.37
T3	1.27	0.37
T4	3.20	0.37

* From package edge to center of component

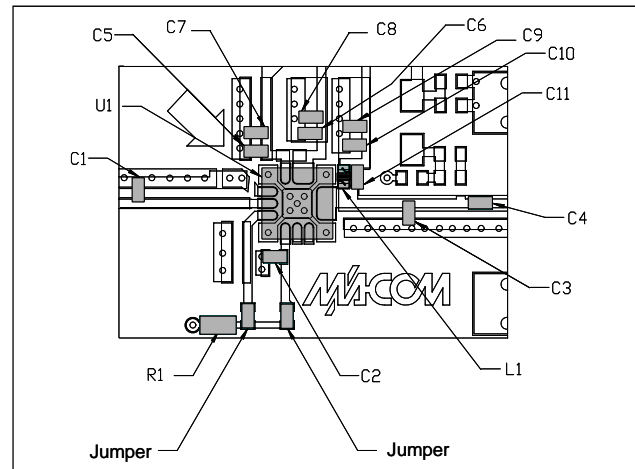

Typical Characteristics (All data uses the supplied sample board BOM)

P_{OUT} , PAE, I_{CC} vs. P_{IN} @ 2.4 V, 2450 MHz

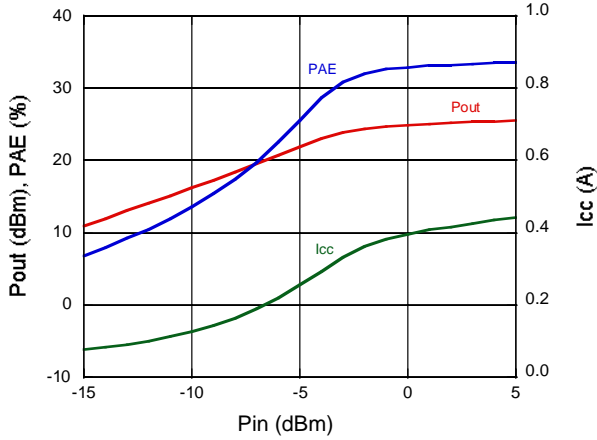

P_{OUT} , PAE, I_{CC} vs. V_{CC} @ 2450 MHz, $P_{IN} = 1$ dBm

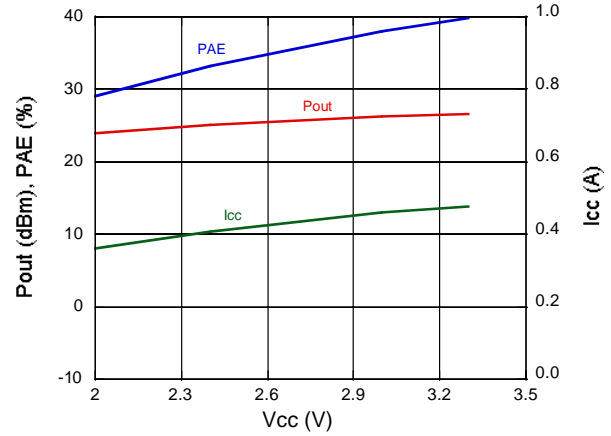

P_{OUT} vs. P_{IN} and Temp @ 2.4 V, 2450 MHz

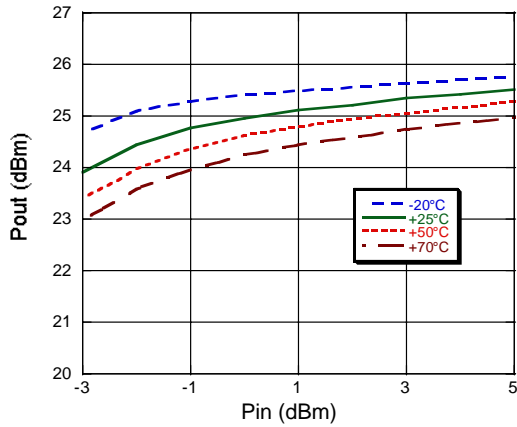

I_{CC} vs. P_{OUT} and Temp @ 2.4 V, 2450 MHz

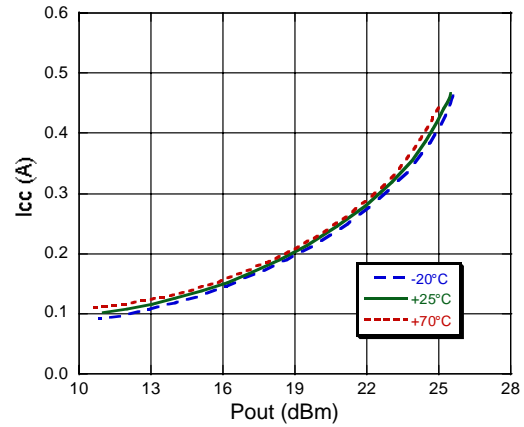

P_{OUT} vs. V_{CC} @ 2450 MHz, $P_{in} = 1$ dBm

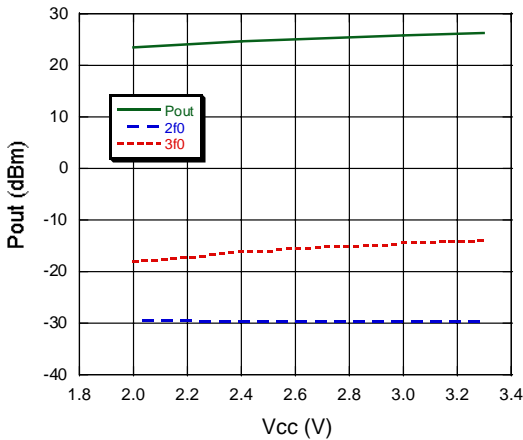

P_{OUT} vs. P_{IN} , $V_{CC} = 2.4$ V @ 2450 MHz

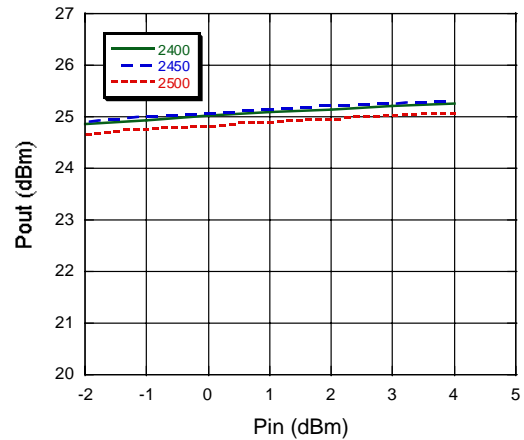

Typical Characteristics (All data uses the supplied sample board BOM)

S21 vs. Frequency @ $V_{CC} = 2.4\text{ V}$, $V_{EN} = 2.5\text{ V}$

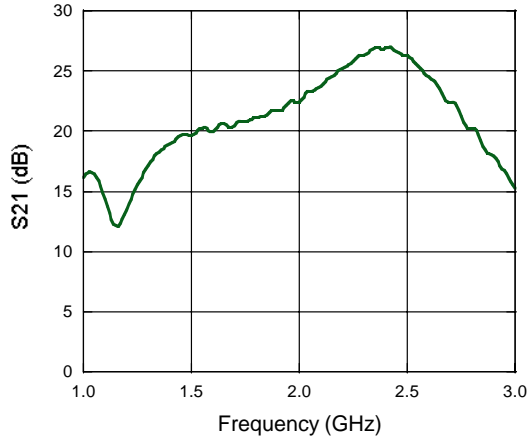

S22, S11 vs. Frequency @ $V_{CC} = 2.4\text{ V}$, $V_{EN} = 2.5\text{ V}$

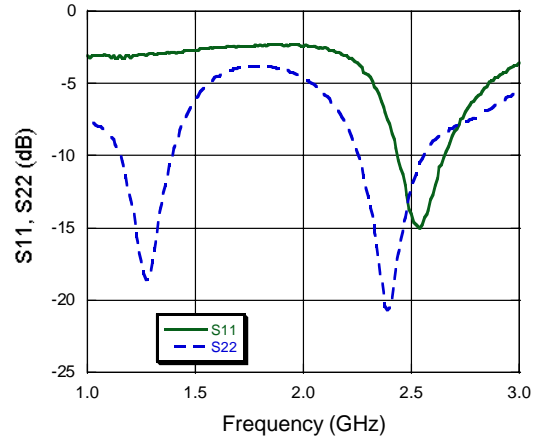

Typical Characteristics, $V_{EN} = 1.7\text{ V}$ (All data uses the supplied sample board BOM)

P_{OUT} , PAE, I_{CC} vs. P_{IN} @ 2.4 V , 2450 MHz

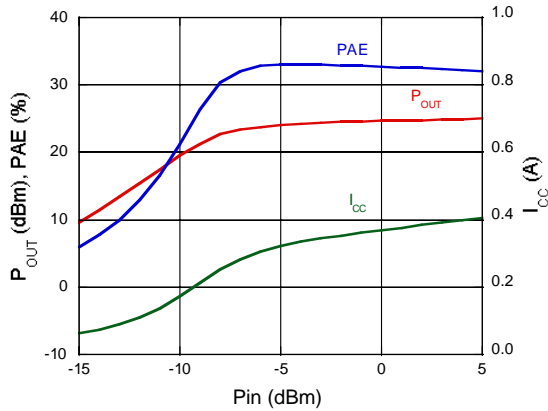

P_{OUT} , PAE, I_{CC} vs. V_{CC} @ 2450 MHz , $P_{IN} = 0\text{ dBm}$

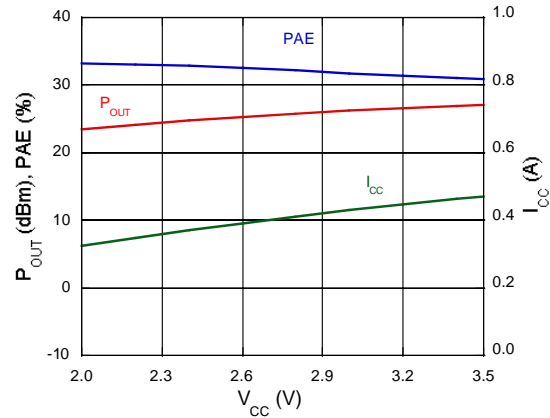

P_{OUT} , PAE, I_{CC} vs. Freq. @ 2450 MHz , $P_{IN} = 0\text{ dBm}$

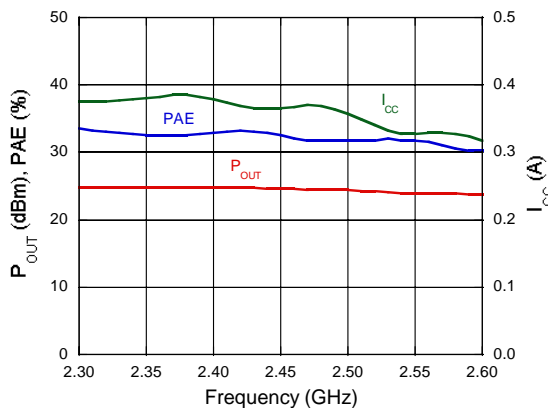

P_{OUT} vs. V_{EN} @ 2.4 V , 2450 MHz , $P_{IN} = 0\text{ dBm}$

