



Dear customers,

About the change in the name such as "Oki Electric Industry Co. Ltd." and "OKI" in documents to OKI Semiconductor Co., Ltd.

The semiconductor business of Oki Electric Industry Co., Ltd. was succeeded to OKI Semiconductor Co., Ltd. on October 1, 2008. Therefore, please accept that although the terms and marks of "Oki Electric Industry Co., Ltd.", "Oki Electric", and "OKI" remain in the documents, they all have been changed to "OKI Semiconductor Co., Ltd.". It is a change of the company name, the company trademark, and the logo, etc. , and NOT a content change in documents.

October 1, 2008
OKI Semiconductor Co., Ltd.

OKI SEMICONDUCTOR CO., LTD.

550-1 Higashiasakawa-cho, Hachioji-shi, Tokyo 193-8550, Japan
<http://www.okisemi.com/en/>

MSC7171

12-Bit Grid Driver

GENERAL DESCRIPTION

The MSC7171 is a driver IC designed to directly drive the grids of fluorescent display tube. It contains a 12-bit shift register and 12 output drivers.

Display data is serially written into the internal 12-bit shift register on the rising edge of each clock pulse.

By setting the DUTY pin to "L", all driver outputs go "L". Blanking can be set using this function. By setting the STANDBY pin to "H", all driver outputs go "L" and the MSC7171 enters the low current mode.

FEATURES

- Logic supply voltage : 5 V
- Driver supply voltage : 65 V
- Driver output current
 - I_{OH} : -50 mA (Only one driver output is in the high state)
 - I_{OL} : 100 μ A
- Directly connectable to VF display tube: no pull-down resistor required
- Data transfer cycle : 5 MHz
- Brightness control through DUTY pin
- Low-current mode can be set with STANDBY pin
- Package:
 - 24-pin plastic SOP (SOP24-P-430-1.27-K)(Product name: MSC7171GS-K)

BLOCK DIAGRAM

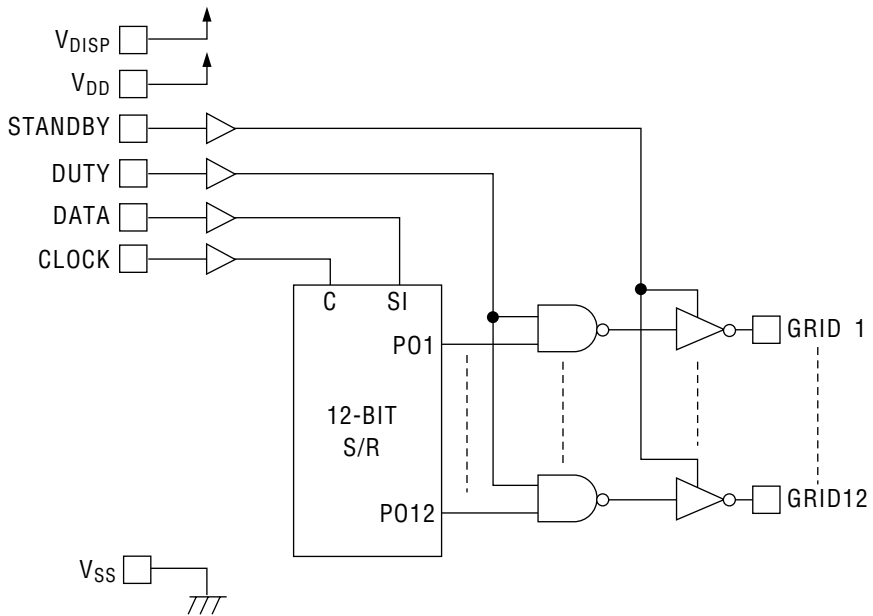

INPUT AND OUTPUT CONFIGURATION

Input Circuit for Logic

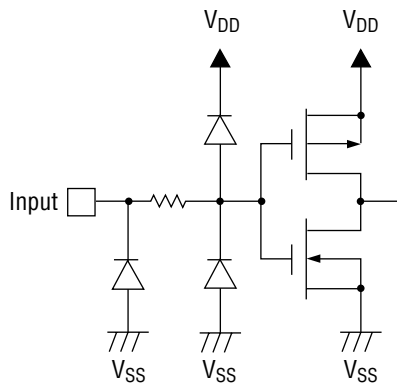

Driver Output Circuit

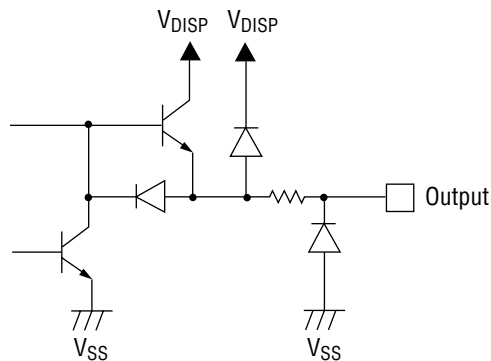

PIN CONFIGURATION (TOP VIEW)

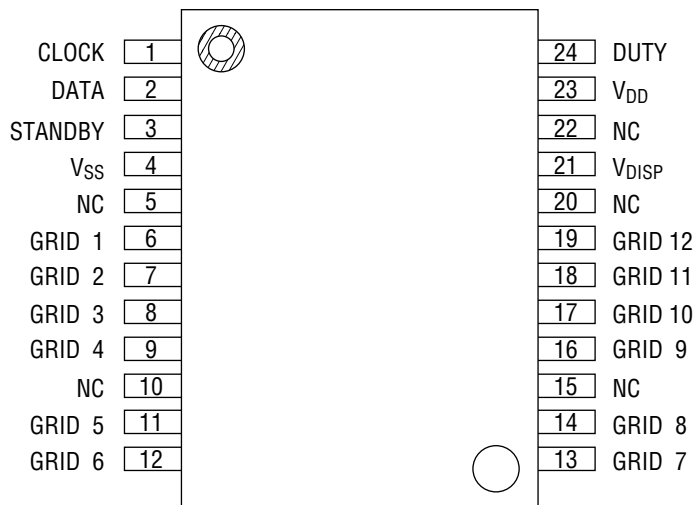

NC: No-connection pin

24-Pin Plastic SOP

PIN DESCRIPTIONS

Symbol	Type	Description
CLOCK	I	Clock input of shift register. Data is clocked in this pin through DATA pin while this pin is at a "L" level. The data is shifted on the rising edge of the shift clock pulse.
DATA	I	Serial data input into the shift register.
STANDBY	I	Standby signal input By setting this pin to "H", all driver outputs go "L" and the IC enters the low current mode.
V _{SS}	—	Ground.
GRID1 to 12	O	High-withstand voltage driver output pins for driving vacuum fluorescent (VF) display tube. These pins can be connected directly to the grids of the VF display tube. No pull-down resistor is required.
V _{DISP}	—	VF display tube driver power supply.
V _{DD}	—	Logic power supply.
DUTY	I	Duty control signal input. When this pin is set to "L", all driver outputs go "L", allowing this pin to be used for brightness control.

ABSOLUTE MAXIMUM RATINGS

Parameter	Symbol	Condition	Rating	Unit	
Logic Supply Voltage	*1	V_{DD}	Applicable to logic power pin	-0.3 to +6.5	V
Driver Supply Voltage	*1,2	V_{DISP}	Applicable to driver power pin	-0.3 to +70	V
Input Voltage	*1	V_{IN}	Applicable to all the input pins	-0.3 to $V_{DD} + 0.3$	V
Power Dissipation		P_D	$T_a \leq 25^\circ\text{C}$	790	mW
Attenuation Rate	*3	R_{j-a}	—	158	$^\circ\text{C/W}$
Storage Temperature		T_{STG}	—	-55 to +150	$^\circ\text{C}$

*1 Voltage for logic with respect to V_{SS}

*2 Stresses beyond the "Absolute Maximum Ratings" may cause permanent damage to the device.

*3 Thermal resistance of the package (between junction and atmosphere)

The junction temperature (T_j) expressed by the equation below must not exceed 150°C .

$T_j = P \times R_{j-a} + T_a$ (P: Maximum power consumption of IC)

RECOMMENDED OPERATING CONDITIONS

Parameter	Symbol	Condition	Min.	Max.	Unit	
Logic Supply Voltage	V_{DD}	Applicable to logic power pin	4.5	5.5	V	
Driver Supply Voltage	V_{DISP}	Applicable to driver power pin	8	65	V	
High Level Input Voltage	V_{IH}	Applicable to all input pins	3.1	—	V	
Low Level Input Voltage	V_{IL}	Applicable to all input pins	—	1.7	V	
Driver High Level Output Current	I_{OH}	Applicable to all driver output pins	—	-50	mA	
Driver Low Level Output Current	I_{OL}	Applicable to all driver output pins	—	100	μA	
Clock Frequency	f_{CLK}	See Timing Diagram	—	1	MHz	
Data Setup Time	$t_{SU(D-CLK)}$	See Timing Diagram	30	—	ns	
Data Hold Time	$t_{H(CLK-D)}$	See Timing Diagram	30	—	ns	
Pulse Width	DUTY	$t_{W(DUTY)}$	See Timing Diagram	100	—	ns
	STANDBY	$t_{W(STB)}$	See Timing Diagram	100	—	ns
Setup Time	CLOCK-DUTY	$t_{SU(CLK-DUTY)}$	See Timing Diagram	100	—	ns
	DUTY-CLOCK	$t_{SU(DUTY-CLK)}$	See Timing Diagram	100	—	ns
	STANDBY-CLK	$t_{SU(STB-CLK)}$	See Timing Diagram	100	—	ns
Operating Temperature	T_{op}	—	-40	85	$^\circ\text{C}$	

ELECTRICAL CHARACTERISTICS

DC Characteristics

($V_{DD}=4.5$ to 5.5 V, $V_{DISP}=8$ to 65 V, $T_a=-40$ to $+85^\circ\text{C}$)

Parameter	Symbol	Condition	Min.	Typ.	Max.	Unit
Logic Power Supply	I_{DD1}	No load, one output H	—	—	0.5	mA
	I_{DD2}	No load, DUTY=L	—	—	0.5	mA
	I_{DD3}	No load, STANDBY=L	—	—	50	μA
Driver Power Supply	I_{DISP1}	No load, one output H	—	—	0.2	mA
	I_{DISP2}	No load, DUTY=L	—	—	1	μA
High Level Input Current	I_{IH}	$V_{DD}=5.5$ V, $V_{IN}=5$ V	—	—	± 1	μA
Low Level Input Current	I_{IL}	$V_{DD}=5.5$ V, $V_{IN}=0.5$ V	—	—	± 1	μA
High Level Output Voltage	V_{OH}	$I_{OH}=-50$ mA	$V_{DISP}-4$	—	—	V
Low Level Output Voltage	V_{OL}	$I_{OL}=100$ μA	—	—	3	V

AC Characteristics

($V_{DD}=4.5$ to 5.5 V, $V_{DISP}=8$ to 65 V, $T_a=-40$ to $+85^\circ\text{C}$)

Parameter	Symbol	Condition	Min.	Typ.	Max.	Unit
Delay Time L→H	t_{DLH}	$C_L=10$ pF	—	0.3	1.0	μs
Transient Time L→H	t_{TLH}	$C_L=10$ pF	—	2.0	4.0	μs
Delay Time H→L	t_{DHL}	$C_L=10$ pF	—	0.3	1.0	μs
Transient Time H→L	t_{THL}	$C_L=10$ pF	—	2.0	4.0	μs

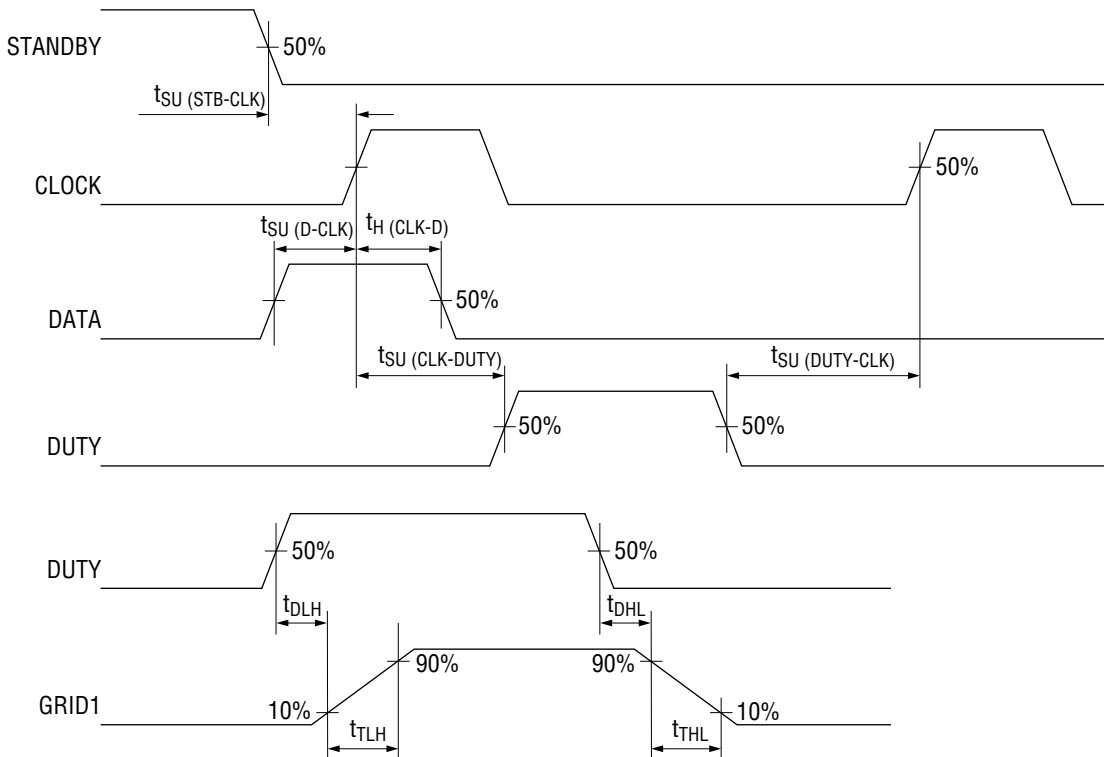

TIMING DIAGRAM



FUNCTIONAL DESCRIPTION

Function Table

Shift register

Input		Shift Register Parallel Out				
CLOCK	DATA	PO1	PO2	...	PO11	PO12
	X	No Change				
	L	L	PO1n	...	PO10n	PO11n
	H	H	PO1n	...	PO10n	PO11n

X: Don't Care

PO1n to PO11n: Data of PO1 to PO11 just before the CLOCK rises

Driver output

Input		Shift Register Parallel Out	Driver Output	Operating Mode
STANDBY	DUTY	POm	DRIDm	
H	X	X	L	Low Current Mode
L	L	X	L	Normal Mode
L	H	L	L	Normal Mode
L		H	H	Normal Mode

X: Don't Care

m: 1 to 12

NOTES ON USE

The contents of the shift register are undefined after power is turned on. Because of this, immediately after power is turned on, some drivers may go "H" to cause the VF display to flicker. To avoid this, first turn on the logic power while holding the STANDBY pin at "H", then turn on the driver power.

After this, set the STANDBY pin to "L" and input data from the DATA pin, then set the DUTY pin to "H" to start for display.

PACKAGE DIMENSIONS

(Unit : mm)

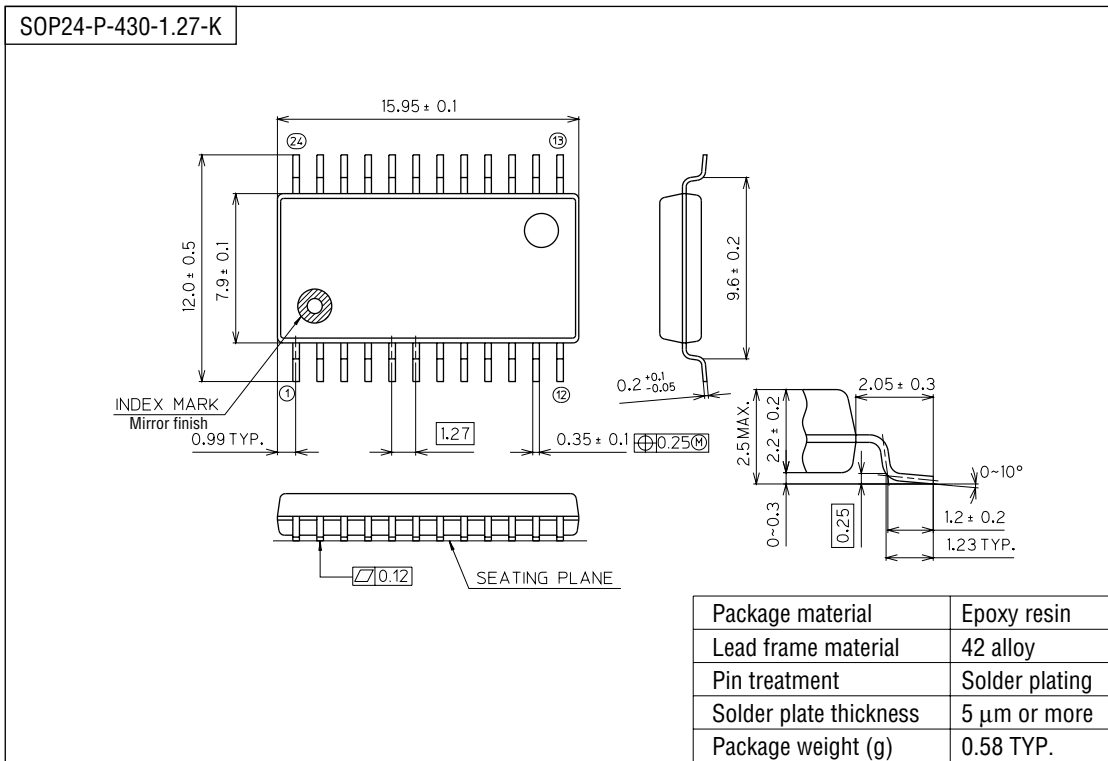

Notes for Mounting the Surface Mount Type Package

The SOP, QFP, TSOP, SOJ, QFJ (PLCC), SHP and BGA are surface mount type packages, which are very susceptible to heat in reflow mounting and humidity absorbed in storage. Therefore, before you perform reflow mounting, contact Oki's responsible sales person for the product name, package name, pin number, package code and desired mounting conditions (reflow method, temperature and times).