

7-Segment LED Display Decoder/Driver with Serial Interface CMOS

The MC14499 is a 7-segment alphanumeric LED decoder/driver with a serial interface port to provide communication with CMOS microprocessors and microcomputers. This device features NPN output drivers which allow interfacing to common cathode LED displays through external series resistors.

- High-Current Segment Drivers On-Chip
- CMOS MPU compatible Input Levels
- Wide Operating Voltage Range: 4.5 to 6.5 V
- Operating Temperature Range: 0 to 70° C
- Drives Four Characters with Decimal Points
- Also See MC14489

BLOCK DIAGRAM

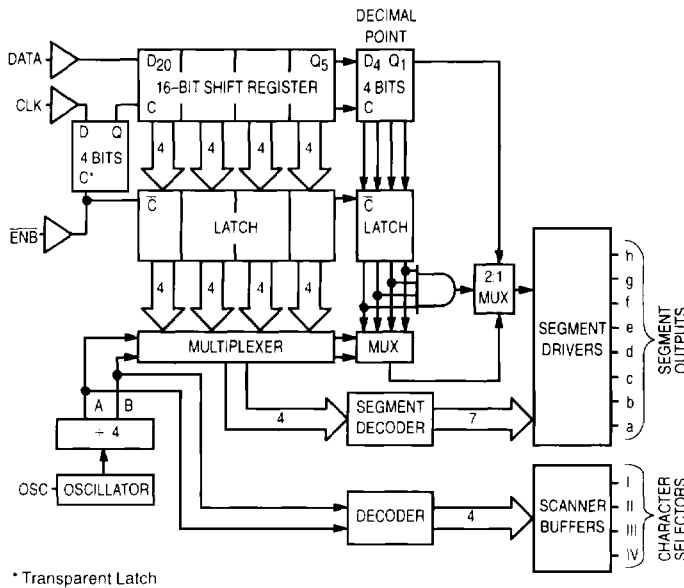

MC14499



P SUFFIX
PLASTIC DIP
CASE 707

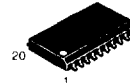

DW SUFFIX
SOG PACKAGE
CASE 751D

ORDERING INFORMATION

MC14499P Plastic DIP
MC14499DW SOG Package

PIN ASSIGNMENTS

PLASTIC DIP

d	1	18	V _{DD}
c	2	17	e
b	3	16	f
a	4	15	g
DATA	5	14	h
OSC	6	13	CLK
IV	7	12	ENB
III	8	11	I
V _{SS}	9	10	II

SOG PACKAGE

d	1	20	V _{DD}
g	2	19	e
c	3	18	f
b	4	17	g
a	5	16	h
DATA	6	15	CLK
OSC	7	14	ENB
IV	8	13	I
III	9	12	II
V _{SS}	10	11	NC

NC = NO CONNECTION

SAME AS IN DL130/D R1

MAXIMUM RATINGS* (Voltages referenced to V_{SS})

Rating	Symbol	Value	Unit
DC Supply Voltage	V _{DD}	- 0.5 to + 7	V
Input Voltage, All inputs	V _{in}	- 0.5 to V _{DD} + 0.5	V
Storage Temperature Range	T _{stg}	- 65 to + 150	°C

* Maximum Ratings are those values beyond which damage to the device may occur. Functional operation should be restricted to the limits in the Electrical Characteristics table or Circuit Operation section.

This device contains circuitry to protect the inputs against damage due to high static voltages or electric fields; however, it is advised that normal precautions be taken to avoid application of any voltage higher than maximum rated voltages to this high impedance circuit. For proper operation, it is recommended that V_{in} and V_{out} be constrained to the range V_{SS} ± (V_{in} or V_{out}) ± V_{DD}.

ELECTRICAL CHARACTERISTICS (V_{DD} = 4.5 to 6.5 V)

Characteristic	Symbol	0 °C		25 °C		70 °C		Unit
		Min	Max	Min	Max	Min	Max	
Serial Port Input Voltage '0' Level '1' Level	V _{IL}	—	0.3 x V _{DD}	—	0.3 x V _{DD}	—	0.3 x V _{DD}	V
	V _{IH}	0.7 x V _{DD}	—	0.7 x V _{DD}	—	0.7 x V _{DD}	—	
Serial Port Input Current (V _{in} = 0 to V _{DD})	I _{in}	—	± 0.1	—	± 0.1	—	± 1.0	µA
Oscillator Input Voltage '0' Level '1' Level	V _{IL}	—	0.25 x V _{DD}	—	0.25 x V _{DD}	—	0.2 x V _{DD}	V
	V _{IH}	0.75 x V _{DD}	—	0.75 x V _{DD}	—	0.8 x V _{DD}	—	
Oscillator Input Current V _{Osc} = 0 V _{Osc} = V _{DD}	I _{IL}	—	100	30	80	10	—	µA
	I _{IH}	—	- 100	- 30	- 80	- 10	—	
Segment Driver Voltage Below V _{DD} I _{out} = 50 mA I _{out} = 10 mA	V _{OH}	—	1.1	—	1.0	—	1.1	V
		—	0.8	—	0.75	—	0.8	
Segment Driver Off Leakage V _{out} = 0	I _{OZ}	—	100	—	50	—	100	µA
Digit Drivers Source (On) Sink (Off)	I _{OH} I _{OL}	6	—	5.5	—	4	—	mA
		- 0.2	—	- 0.2	—	- 0.1	—	
Supply Current V _{in} = 0, I _{out} = 0, C _{Osc} = 0.015 µF	I _{DD}	—	1	—	1	—	1	mA
Maximum Power Dissipation	P _D	—	500	—	500	—	500	mW

SWITCHING CHARACTERISTICS (V_{DD} = 5 V ± 10%, T_A = 0 to 70 °C)

Characteristic	Figure No.	Symbol	Min	Max	Unit
Clock High Time	2	t _{CH}	2	—	µs
Clock Low Time	2	t _{CL}	2	—	µs
Clock Rise Time	2	t _{CR}	—	2	µs
Clock Fall Time	2	t _{CF}	—	2	µs
Enable Lead Time	2	t _{E LEAD}	200	—	ns
Enable Lag Time	2	t _{E LAG}	200	—	ns
Data Set-Up Time	2	t _{D SUP}	200	—	ns
Data Hold Time	2	t _{D HOLD}	1	—	µs
Scanner Frequency*	4	1/t _{SCAN}	50	300	Hz
OSC/Digit Lead Time	4	t _{OD}	—	10	µs
OSC/Segment Lead Time	4	t _{OS}	—	10	µs
Digit Overlap	4	t _{OV}	—	5	µs

* Scanner Capacitance = 0.022 µF.

CIRCUIT OPERATION

The circuit accepts a 20-bit input, 16 bits for the four-digit display plus 4 bits for the decimal point — these latter four bits are optional.

The input sequence is the decimal point code followed by the four digits, as shown in Figure 1.

In order to enter data the enable input, \overline{ENB} , must be active low. The sample and shift are accomplished on the falling clock edge, see Figure 2. Data are loaded from the shift register to the latches when \overline{ENB} goes high. While the shift register is being loaded, the previous data are stored in the latches.

If the decimal point is used, the system requires 20 clock pulses to load data; otherwise only 16 are required.

CASCADING

The circuit may be cascaded in the following manner.

If a 1111 word is loaded into the decimal point latch, the output of the shift register is switched to the decimal point driver, see Figure 3. Therefore, to cascade n four-digit display drivers, a set-up is used which loads the 1111 cascading word:

1. \overline{ENB} = active low.
2. Load 20 bits, the first four bits being 1, with 20 clock pulses.
3. \overline{ENB} = high, to load the latch.
4. Repeat steps 1 to 3 (n - 1) times.

5. (n x 20) bits can be loaded into n circuits, with 1111 as decimal point word to continue the cascading.

SCANNER

The scanner frequency is determined by an on-chip oscillator, which requires an external frequency-determining capacitor. The capacitor voltage varies between two trigger levels at the oscillator frequency.

An external oscillator signal can be used, within the recommended operating range of 200 to 800 Hz. For test purposes this frequency may be increased up to 10 kHz.

A divide by four counter provides four non-overlapping scanner waveforms corresponding to the four digits — see Figure 4.

SEGMENT DECODER

The code used in these matrix decoders is shown in Figure 5.

OUTPUT DRIVERS

There are two different drivers:

- The segment and decimal point drivers; these are NPN emitter followers with no current limiting devices.
- The digit output buffers; these are short-circuit protected CMOS devices.

A typical application circuit is shown in Figure 6.

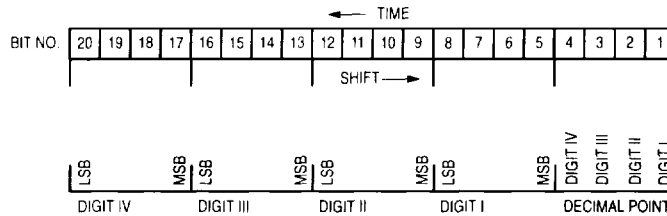

Figure 1. Input Sequence

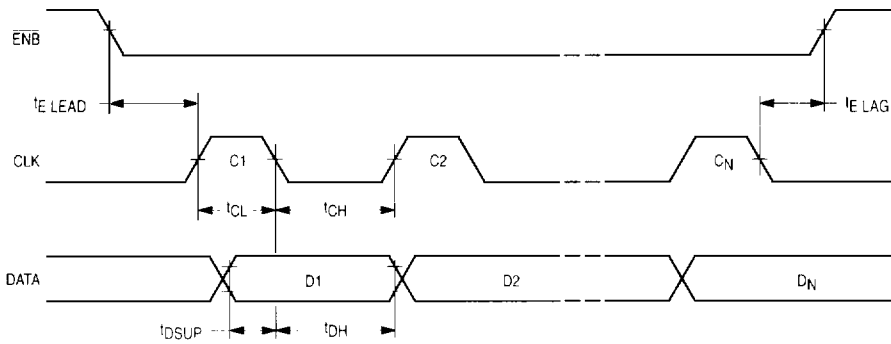

Figure 2a. Serial Input, Positive Clock

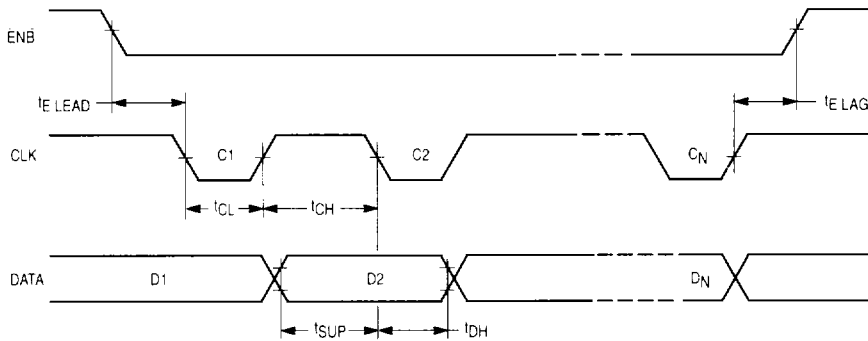

Figure 2b. Serial Input, Negative Clock

Figure 2. Serial Input

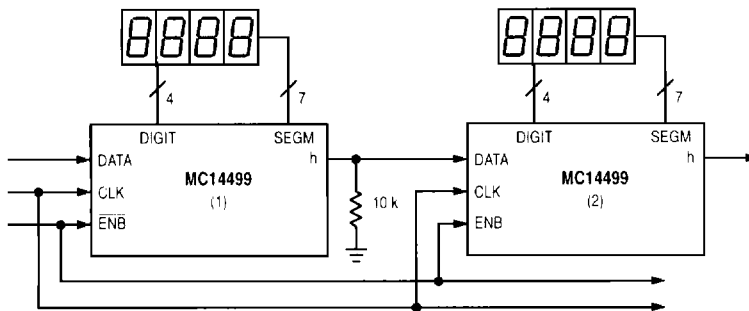

Figure 3. Cascading MC14499s

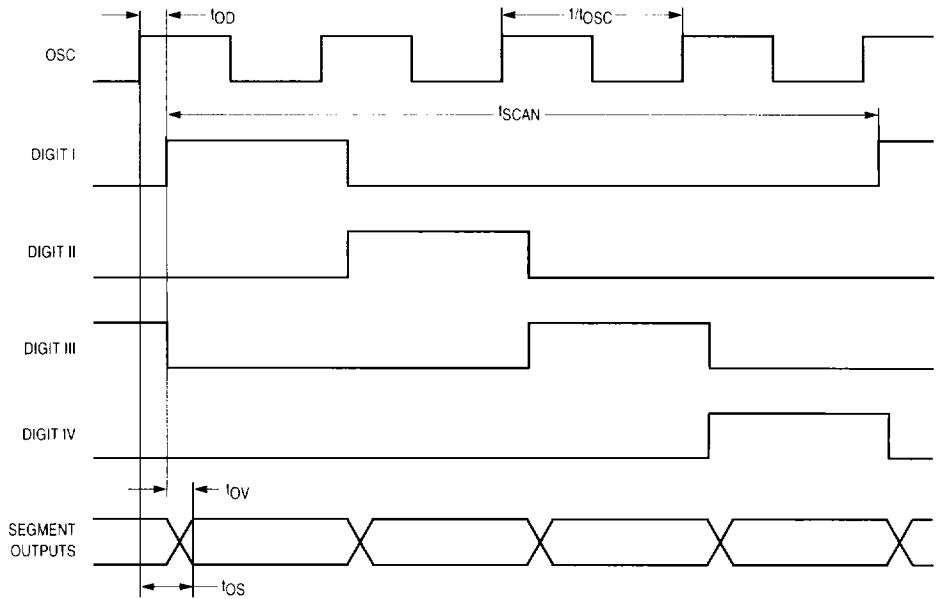

Figure 4. Scanner Waveforms

0000	0	1000	8
0001	1	1001	9
0010	2	1010	A
0011	3	1011	I
0100	4	1100	11
0101	5	1101	U
0110	6	1110	DASH -
0111	7	1111	BLANK

Figure 5. Segment Code

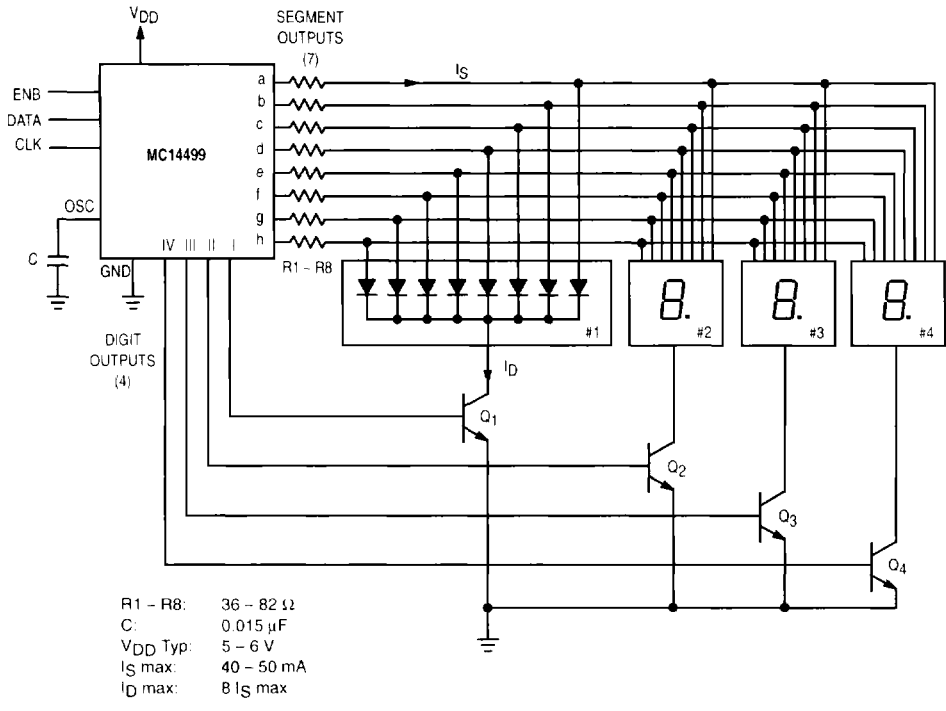

Figure 6. Application Example