

M66271FP

Operation Panel Controller

REJ03F0267-0200

Rev.2.00

Mar 18, 2008

Description

The M66271FP is a graphic display-only controller for displaying a high duty dot matrix type LCD which is used widely for PPC, FAX and multi-function telephones.

It is capable of controlling a monochrome STN LCD system of up to 320×240 dots.

The IC has a built-in 9600-byte VRAM as a display data memory.

All of the VRAM addresses are externally opened. Address mapping in the MPU memory space allows direct addressing of all display data from the MPU, thus providing efficient display data processing such as drawing.

The built-in arbiter circuit (cycle steal system) which gives priority to display access allows timing-free access from MPU to VRAM, preventing display screen distortion.

The IC provides interface with a 8-bit/16-bit MPU with a $\overline{\text{READY}}$ ($\overline{\text{WAIT}}$) pin.

And this IC has a function for LCD module built-in system by lessening connect pins between MPU.

Features

- Displayable LCD
 - Monochrome STN dot matrix type LCD of up to 76800 dots (equivalent to 320×240 dots)
 - Maximum display duty: 1/240 (set to 240 line)
: 1/255 (Max)
- Display memory
 - Built-in 9600-byte (76800-bit) VRAM (equivalent to one screen of 320×240 dots LCD)
 - All addresses of built-in VRAM are externally opened.
- Interface with MPU
 - Capability of switching 8-bit type MPU/16-bit type MPU
 - With $\overline{\text{WAIT}}$ output pin (Accessing register from MPU without $\overline{\text{WAIT}}$ output. Accessing VRAM from MPU with $\overline{\text{WAIT}}$ output.)
 - Capability of controlling $\overline{\text{BHE}}$ or $\overline{\text{LWR}}/\overline{\text{HWR}}$ at the interface with a 16-bit MPU.
- Interface with LCD
 - LCD display data are 4-bit parallel output
 - 4 kinds of control signals: CP, LP, FLM and M
- Display functions
 - Graphic display only (characters drawn graphically)
 - Binary display only (without tone display function)
 - Vertical scrolling is allowed within memory range (small size LCD only)
- Additional function for LCD module built-in system
 - 15 kinds of interface with MPU: A <4:1>, D <7:0>, $\overline{\text{IOCS}}$, $\overline{\text{LWR}}$, $\overline{\text{RD}}$
 - Accessing VRAM from MPU through I/O register
 - Capability of interfacing with 8-bit type MPU only
- 5 V single power supply
- 80-pin QFP

Application

- PPC/FAX operation panel, display/operation panel of other OA equipment
- Multi-function/public telephones
- PDA/electronic notebook/information terminal
- Other applications using LCD of 76800 dots or less

Block Diagram 1

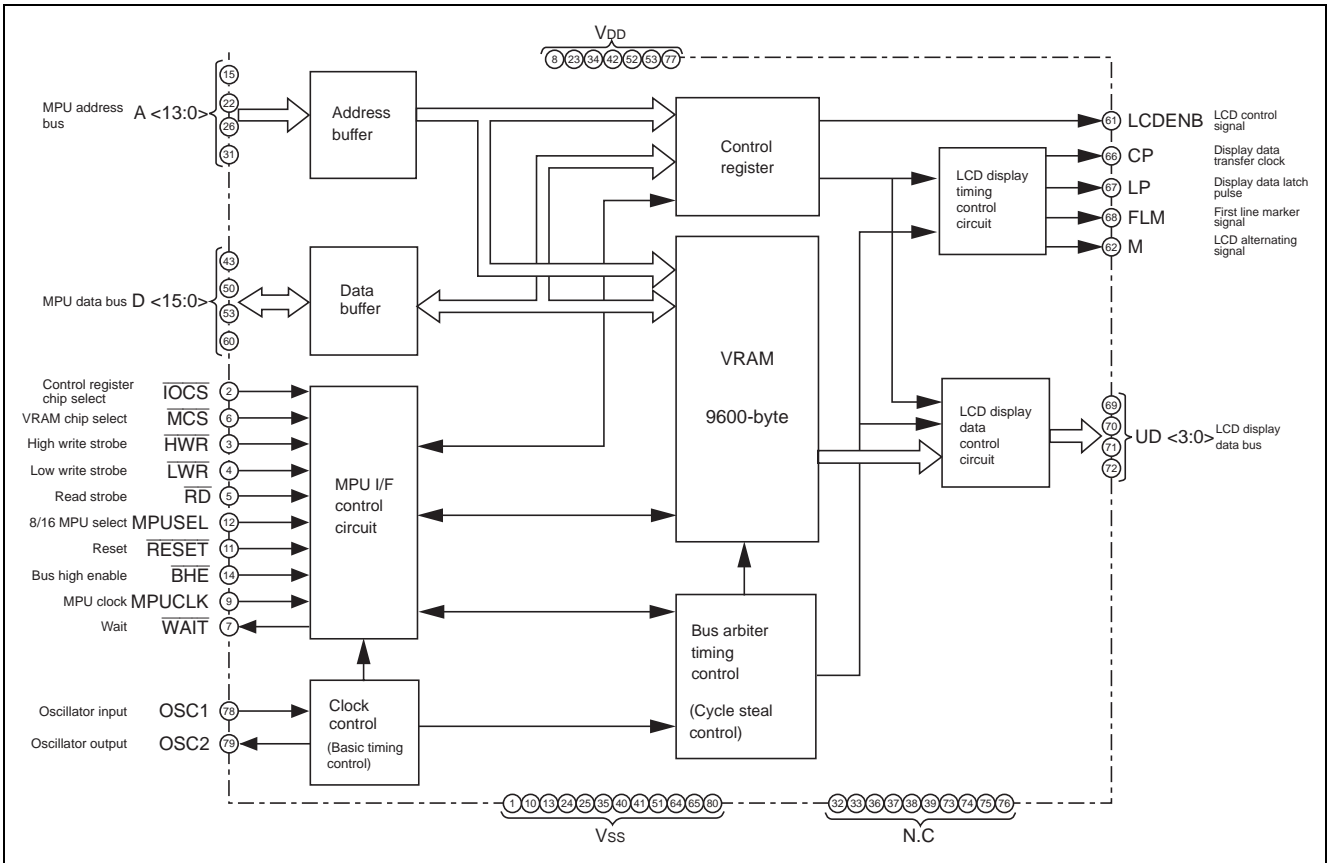

Block Diagram 2 (In case of LCD module built-in system)

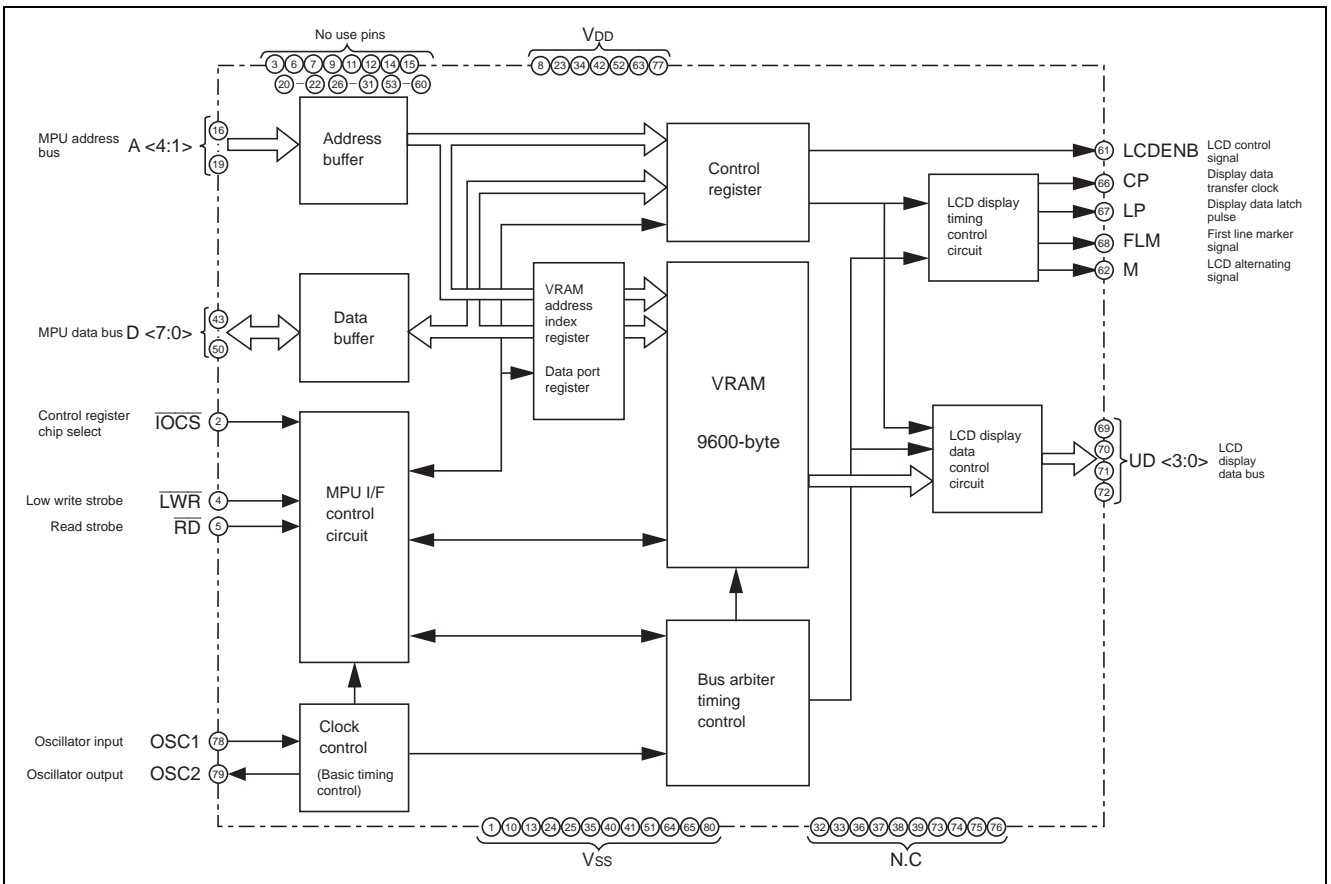

Pin Arrangement

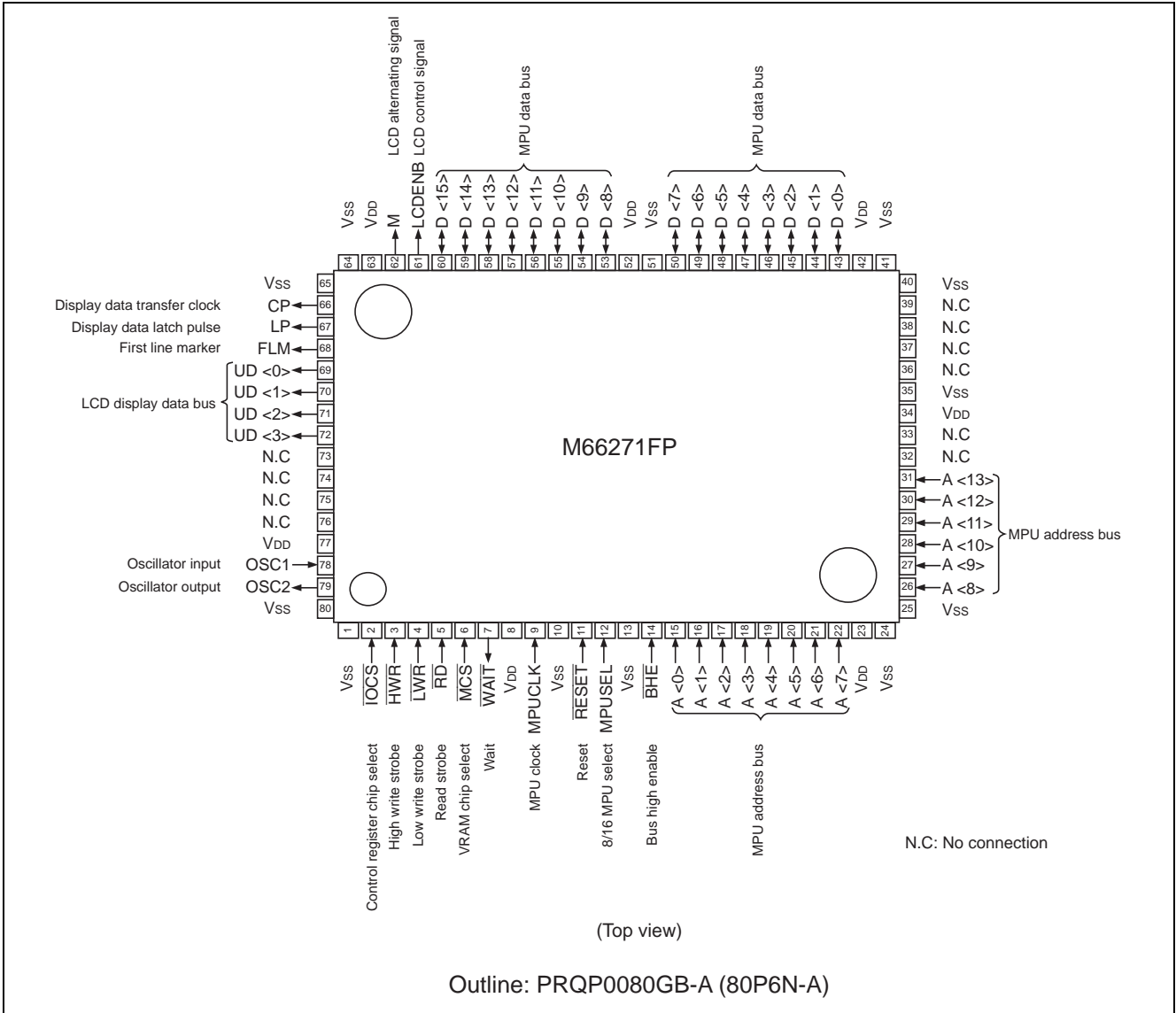

Pin Description

Item	Pin Name	Input/ Output	Function	Number of Pins
MPU interface	D <15:0>	Input/ Output	MPU data bus Connect to MPU data bus. Selecting 8-bit MPU by MPUSEL input, D <15:8> connect to V _{DD} or V _{SS}	16
	A <13:0>	Input	MPU address bus Connect to MPU address bus. When selecting 8-bit MPU, use A <13:0>. And selecting 16-bit MPU, use A <13:1> for the address bus with combining A <0> and BHE by the method of access to internal VRAM (Refer to figure 1). Use A <4:0> for selecting address of control register.	14
	$\overline{\text{IOCS}}$	Input	Chip select input of control register When this pin is "L", select the internal control register. Assign to I/O space of MPU.	1
	$\overline{\text{MCS}}$	Input	Chip select input of VRAM When this pin is "L", select the internal VRAM. Assign to memory space of MPU.	1
	$\overline{\text{HWR}}$	Input	High-write strobe input When this pin is "L", data write to the internal VRAM. $\overline{\text{HWR}}$ is valid only in using 16-bit MPU controlled byte access by $\overline{\text{LWR}}$ and $\overline{\text{HWR}}$. (Refer to figure 1)	1
	$\overline{\text{LWR}}$	Input	Low-write strobe input When this pin is "L", data write to the internal control register or VRAM. (Refer to figure 1)	1
	$\overline{\text{RD}}$	Input	Read strobe input When this pin is "L", data read from the internal control register or VRAM. (Refer to figure 1)	1
	MPUSEL	Input	8/16-bit MPU select input According to MPU, set "V _{SS} " for 8-bit MPU and set "V _{DD} " for 16-bit MPU	1
	RESET	Input	Reset input Use reset signal of MPU. When this pin is "L", initialize all internal control register and counter.	1
	MPUCLK	Input	MPU clock Input of MPU clock.	1
	BHE	Input	Bus-high-enable input This pin is valid when using 16-bit MPU controlled byte access by A <0> and $\overline{\text{BHE}}$ (Refer to figure 1). Connect to "V _{DD} " when using 8-bit MPU. Set to "L" when using the additional function for the LCD module built-in system.	1
	WAIT	Output	WAIT output for MPU This signal makes WAIT for MPU. Change WAIT "L" at timing of falling edge of overlapping with $\overline{\text{MCS}}$ and ($\overline{\text{RD}}$ or $\overline{\text{LWR}}$ or $\overline{\text{HWR}}$). And return to "H" at synchronizing with the rising edge of MPUCLK after internal processing. (Output WAIT only when requested access from MPU to VRAM during cycle steal access.)	1
LCD interface	UD <3:0>	Output	Display data bus for LCD Transfer the LCD display data with 4-bit parallel signal. Mutually output upper/lower data every CP output.	4
	CP	Output	Display data transfer clock Shift clock for the transfer of display data to LCD. Take the display data of UD <3:0> to LCD at falling edge of CP.	1
	LP	Output	Display data latch pulse This clock use both as the latch pulse of display data for LCD and the transfer of scanning signal. LP output when finish the transfer of display data of a line. Latch of display data and the transfer of scanning signal at falling edge of LP.	1
	FLM	Output	First line marker signal Output the start pulse of scanning line. This signal is "H" active, the IC for driving scanning line catch FLM at falling edge of LP.	1
	M	Output	LCD alternating signal output Signal for driving LCD by alternating current.	1
	LCDENB	Output	LCD (ON/OFF) control signal output Output data which is set at bit "0" of mode register (R1) in control register. This signal can use for controlling the LCD power supply, because LCDENB set to "L" by RESET.	1
Oscillator	OSC1	Input	Input pin for oscillator	1
	OSC2	Output	Output pin for oscillator	1
Others	V _{DD}	—	Power supply (source + 5 V)	7
	V _{SS}	—	Ground	12
	N.C	—	No connection	10

Absolute Maximum Ratings

(Ta = 0 to +70°C unless otherwise noted)

Item	Symbol	Ratings	Unit
Supply voltage	V _{DD}	-0.3 to +6.5	V
Input voltage	V _I	-0.3 to V _{DD} + 0.3	V
Output voltage	V _O	-0.3 to V _{DD} + 0.3	V
Output current	I _O	10	mA
Power dissipation	P _d	600	mW
Storage temperature	T _{stg}	-55 to +150	°C

Recommended Operating Conditions

(Ta = 0 to +70°C unless otherwise noted)

Item	Symbol	Min	Typ	Max	Unit
Supply voltage	V _{DD}	4.5	5.0	5.5	V
Supply voltage	V _{SS}	—	0	—	V
Input voltage	V _I	0	—	V _{DD}	V
Output voltage	V _O	0	—	V _{DD}	V
Operating temperature	T _{opr}	0	+25	+70	°C

Electrical Characteristics

(V_{DD} = 5 V ± 10%, Ta = 0 to +70°C unless otherwise noted)

Item		Symbol	Min	Typ	Max	Unit	Test Conditions
High-level input voltage	All inputs except for OSC1, $\overline{\text{RESET}}$ and MPUSEL	V _{IH}	2.2	—	—	V	V _{DD} = 5.5 V
Low-level input voltage		V _{IL}	—	—	0.8	V	V _{DD} = 4.5 V
High-level input voltage	OSC1	V _{IH}	3.5	—	—	V	V _{DD} = 5.5 V
Low-level input voltage		V _{IL}	—	—	1.0	V	V _{DD} = 4.5 V
Positive-going threshold voltage	MPUSEL, $\overline{\text{RESET}}$	V _{T+}	2.3	—	3.7	V	V _{DD} = 5.0 V
Negative-going threshold voltage		V _{T-}	1.25	—	2.3	V	V _{DD} = 5.0 V
High-level output voltage	All outputs except for OSC2 and outputs of D <15:0>	V _{OH}	4.1	—	—	V	V _{DD} = 4.5 V I _{OH} = -4 mA
Low-level output voltage		V _{OL}	—	—	0.4	V	
High-level output voltage	OSC2	V _{OH}	4.1	—	—	V	V _{DD} = 4.5 V I _{OH} = -50 μA
Low-level output voltage		V _{OL}	—	—	0.4	V	
High-level input current		I _{IH}	—	—	10	A	V _{DD} = 5.5 V, V _I = V _{DD}
Low-level input current		I _{IL}	—	—	-10	A	V _{DD} = 5.5 V, V _I = V _{SS}
Off-state high-level output current	D <15:0>	I _{OZH}	—	—	10	A	V _{DD} = 5.5 V, V _O = V _{DD}
Off-state low-level output current		I _{OZL}	—	—	-10	A	V _{DD} = 5.5 V, V _O = V _{SS}
Operating supply current (Average)		I _{DD(A)}	—	—	40	mA	V _{DD} = 5.5 V, V _I = V _{DD} or V _{SS} f _{osc} = 10 MHz, Output = open
Stand-by supply current		I _{DD(S)}	—	—	500	A	V _{DD} = 5.5 V, $\overline{\text{IOCS}}, \overline{\text{MCS}} = V_{\text{DD}}$ Other's V _I = V _{DD} or V _{SS} (valid)

Switching Characteristics

 $(V_{DD} = 5\text{ V} \pm 10\%, T_a = 0\text{ to }+70^\circ\text{C}, C_L = 50\text{ pF})$

Item	Symbol	Min	Typ	Max	Unit
IOCS data access time	t_a (IOCS-D)	—	—	70	ns
MCS data access time	t_a (MCS-D)	—	—	—	—
RD data access time	t_a (RD-D)	—	—	—	—
Output disable time after IOCS	t_{dis} (IOCS-D)	—	—	20	ns
Output disable time after MCS	t_{dis} (MCS-D)	—	—	—	—
Output disable time after RD	t_{dis} (RD-D)	—	—	—	—
WAIT output propagation time after MCS	t_{pHL} (MCS-WAIT)	—	—	40	ns
WAIT output propagation time after WR	t_{pHL} (WR-WAIT)	—	—	—	—
WAIT output propagation time after RD	t_{pHL} (RD-WAIT)	—	—	—	—
WAIT output propagation time after MPUCLK	t_{pLH} (CLK-WAIT)	—	—	20	ns
CP output propagation time after OSC	t_{pd} (OSC-CP)	—	—	40	ns
LP output propagation time after OSC	t_{pLH} (OSC-LP) t_{pHL} (OSC-LP)	—	—	40	ns
UD access time	t_a (UD)	—	—	40	ns
FLM output propagation time after OSC	t_{pLH} (OSC-FLM) t_{pHL} (OSC-FLM)	—	—	40	ns
M output propagation time after OSC	t_{pd} (OSC-M)	—	—	40	ns
LCDENB output propagation time after OSC	t_{pLH} (OSC-LE) t_{pHL} (OSC-LE)	—	—	40	ns
Data definite time before canceling WAIT	t_{pd} (D-WAIT)	0	—	—	ns

Timing Requirements

 $(V_{DD} = 5\text{ V} \pm 10\%, T_a = 0\text{ to }+70^\circ\text{C})$

(1) Accessing to Control Register

Item	Symbol	Min	Typ	Max	Unit
IOCS pulse width	t_W (IOCS)	70	—	—	ns
LWR pulse width	t_W (LWR)	—	—	—	—
Data set up time before falling edge of IOCS	t_{su} (D-IOCS)	0	—	—	ns
Data set up time before falling edge of LWR	t_{su} (D-LWR)	—	—	—	—
Data hold time after rising edge of IOCS	t_h (IOCS-D)	15	—	—	ns
Date hold time after rising edge of LWR	t_h (LWR-D)	—	—	—	—
Address set up time before falling edge of IOCS	t_{su} (A-IOCS)	15	—	—	ns
Address set up time before falling edge of LWR	t_{su} (A-LWR)	—	—	—	—
Address set up time before falling edge of RD	t_{su} (A-RD)	—	—	—	—
Address hold time after rising edge of IOCS	t_h (IOCS-A)	15	—	—	ns
Address hold time after rising edge of LWR	t_h (LWR-A)	—	—	—	—
Address hold time after rising edge of RD	t_h (RD-A)	—	—	—	—

(2) Accessing to VRAM

Item	Symbol	Min	Typ	Max	Unit
MCS pulse width	t_W (MCS)	70	—	—	ns
WR pulse width	t_W (WR)				
Data set up time before falling edge of MCS	t_{su} (D-MCS)	0	—	—	ns
Data set up time before falling edge of WR	t_{su} (D-WR)				
Data hold time after rising edge of MCS	t_h (MCS-D)	15	—	—	ns
Data hold time after rising edge of WR	t_h (WR-D)				
Address set up time before falling edge of MCS	t_{su} (A-MCS)	15	—	—	ns
Address set up time before falling edge of WR	t_{su} (A-WR)				
Address set up time before falling edge of RD	t_{su} (A-RD)				
Address hold time after rising edge of MCS	t_h (MCS-A)	15	—	—	ns
Address hold time after rising edge of WR	t_h (WR-A)				
Address hold time after rising edge of RD	t_h (RD-A)				

(3) Clock and Accessing to LCD Display

Item	Symbol	Min	Typ	Max	Unit
MPUCLK cycle time	t_C (CLK)	50	—	—	ns
MPUCLK "H" pulse width	t_{WH} (CLK)	—	$\frac{t_C (CLK)}{2}$	—	ns
MPUCLK "L" pulse width	t_{WL} (CLK)				
OSC cycle time	t_C (OSC)	50*	—	—	ns
OSC "H" pulse width	t_{WH} (OSC)	—	$\frac{t_C (OSC)}{2}$	—	ns
OSC "L" pulse width	t_{WL} (OSC)				
CP cycle time	t_C (CP)	—	$\frac{t_C (OSC)}{(1/n)}$	—	ns
CP "H" pulse width	t_{WH} (CP)	—	$\frac{t_C (OSC)}{2 \cdot (1/n)}$	—	ns
CP "L" pulse width	t_{WL} (CP)				
FLM pulse width	t_W (FLM)	—	$\frac{2 \cdot t_C (OSC) \cdot LPW}{(1/n)}$	—	ns

Note: Clock frequency of OSC1 input is less than $f_{max} = 20$ MHz.

Limit of OSC clock for the internal operation is $f_{max} = 10$ MHz.

When OSC1 is more than 10 MHz from external input, set OSC clock up to 10 MHz by using division of OSCC register.

Division is set with rising edge of OSC1 input.

$1/n$ = Division of OSC1

LPW = Setting value of LPW register

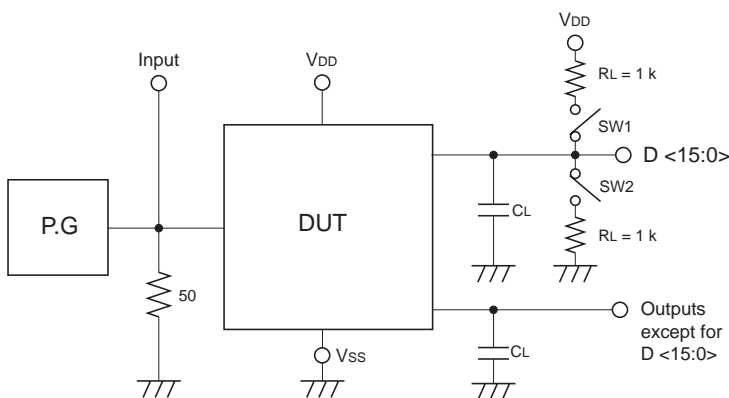
Test Circuit

Item	SW1	SW2
t_{dis} (LZ)	Closed	Open
t_{dis} (HZ)	Open	Closed
t_a (ZL)	Closed	Open
t_a (ZH)	Open	Closed

(1) Input pulse level: 0 to 3 V

Input pulse rise/fall time: $t_r, t_f = 3$ ns

Input decision voltage: 1.5 V

Output decision voltage: $V_{DD}/2$

(However, t_{dis} (LZ) is 10% of output amplitude and t_{dis} (HZ) is 90% of that for decision.)

(2) Load capacity C_L include float capacity of connection and input capacity of probe.

Outline

M66271FP is graphic display only controller for displaying a dot matrix type LCD. This IC has a built-in display data memory (VRAM) which is equivalent to 320 × 240 dots LCD.

- Control register

When access the control register from MPU side, use $\overline{\text{IOCS}}$, $\overline{\text{LWR}}$, $\overline{\text{RD}}$, A <4:0> and D <7:0>. Refer to table 1, when set control type inputs.

Control registers are R1 to R8 for the normal mode function and R9 to R11 for the exclusive register for the LCD module built-in system.
- VRAM

When access VRAM from MPU side, use $\overline{\text{MCS}}$, $\overline{\text{HWR}}$, $\overline{\text{LWR}}$, $\overline{\text{RD}}$, $\overline{\text{BHE}}$, A <13:0> and D <15:0>. And enable to correspond to both 8-bit and 16-bit MPU by using MPUSEL input. Refer to figure 1 and table 2 to 6 for a form of VRAM and input setting for 8/16-bit MPU.
- Cycle steal system

Cycle steal is interact method of transferring display data for LCD from VRAM and accessing VRAM from MPU on the basic cycle of OSC.

Basic timing is two clocks of OSC, and assign first clock to the access from MPU to VRAM and second clock to the transfer of display data from VRAM to LCD.

In accessing VRAM from MPU, output $\overline{\text{WAIT}}$. Change $\overline{\text{WAIT}}$ to "L" at the timing of the falling edge of overlapping with $\overline{\text{MCS}}$ and ($\overline{\text{RD}}$ or $\overline{\text{LWR/HWR}}$). And return to "H" at synchronizing with rising edge of MPUCCLK after internal processing.

Cycle steal system can transfer data with more efficient. This function access with the cycle steal method as taking $\overline{\text{WAIT}}$ for MPU during the display term with necessity for the display data transfer from built-in VRAM to LCD. On other side, don't output $\overline{\text{WAIT}}$ for keeping throughput of MPU during horizontal synchronous term with no necessity for the display data transfer from VRAM to LCD side.

Refer to the following description of cycle steal.
- Output to LCD side

LCD display data UD <3:0> output synchronized with the rising edge of CP output per 4 bits.

LP output synchronized with the falling edge of OSC when finish the transfer of display data for a line.

Enable to adjust the fittest value of the frame frequency requested by the LCD PANEL side with adjusting pulse width by LPW register.

FLM output, when finish the transfer of display data of 1st line.

M output is the LCD alternating signal which is signal for driving LCD by alternating current.

M-cycle enable to set variably by M-cycle variable register in line unit, and enable to utilize for preventing LCD from being inferior.

Difference in VRAM between 8-bit and 16-bit MPU

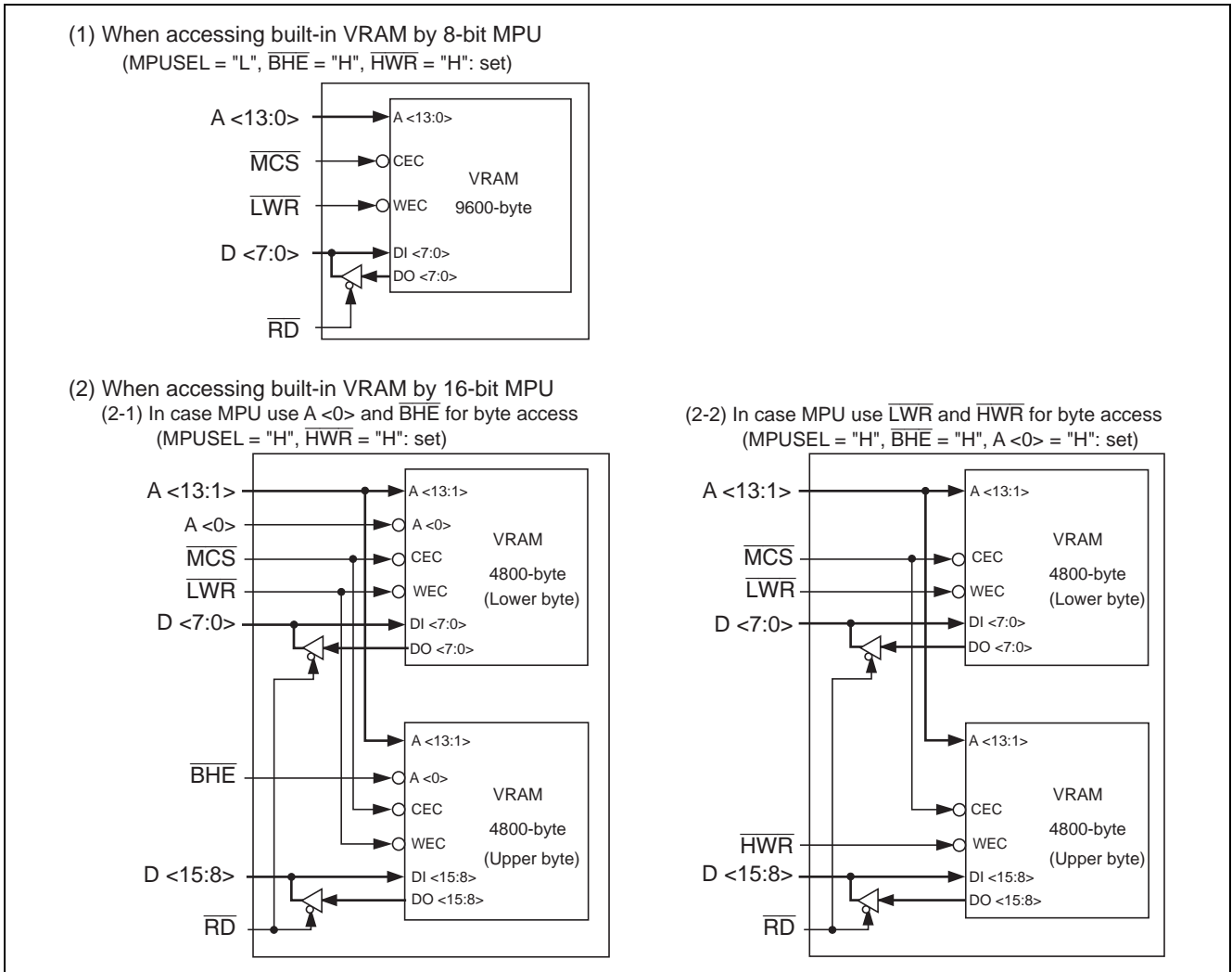

Figure 1 Difference in VRAM between 8-bit and 16-bit MPU

Combination of Control Input Pins for MPU Interface

Table 1 to 6 show conditions of input setting when access the control register and VRAM from MPU.

(1) Access control register (Use address = A <4:0>, Data = D <7:0>)

Table 1

$\overline{\text{IOCS}}$	$\overline{\text{LWR}}$	$\overline{\text{RD}}$	Operation
L	L	H	Write to control register
L	H	L	Read from control register
H	X	X	Invalid

(2) Writing to VRAM

(2-1) When use 8-bit MPU (MPUSEL = "L", $\overline{\text{BHE}} = \overline{\text{HWR}} = \text{"H"}$: set)

Table 2

MPU SEL	$\overline{\text{MCS}}$	$\overline{\text{BHE}}$	A <0>	$\overline{\text{HWR}}$	$\overline{\text{LWR}}$	Odd Address	Even Address	Valid Data Bus Width of MPU
L	L	H	L	H	L	Invalid	Write	8-bit
			H		H	Write	Invalid	
	X		H		Invalid	Invalid		
	X		X		Invalid	Invalid		
H	H	X	X	X	X	X	X	

(2-2) When use 16-bit MPU (In MPU controls byte access with A <0> and $\overline{\text{BHE}}$, MPUSEL = $\overline{\text{HWR}} = \text{"H"}$: set)

Table 3

MPU SEL	$\overline{\text{MCS}}$	$\overline{\text{BHE}}$	A <0>	$\overline{\text{HWR}}$	$\overline{\text{LWR}}$	Upper Byte	Lower Byte	Valid Data Bus Width of MPU	
H	L	L	L	H	L	Write	Write	16-bit	
			H		H	Invalid	Invalid		
			X		L	Write	Invalid		Upper 8-bit
			X		H	Invalid	Invalid		
	H	X	X		L	L	Invalid	Write	Lower 8-bit
					H	H	Invalid	Invalid	
					X	L	Invalid	Write	
					X	H	Invalid	Invalid	
H	H	X	X	X	X	X	X		

← Even if A <0> = "H", enable to write

(2-3) When use 16-bit MPU

(In MPU controls byte access with $\overline{\text{LWR}}$ and $\overline{\text{HWR}}$, MPUSEL = $\overline{\text{BHE}} = \text{A <0>} = \text{"H"}$: set)

Table 4

MPU SEL	$\overline{\text{MCS}}$	$\overline{\text{BHE}}$	A <0>	$\overline{\text{HWR}}$	$\overline{\text{LWR}}$	Upper Byte	Lower Byte	Valid Data Bus Width of MPU
H	L	H	H	L	L	Write	Write	16-bit
					H	Write	Invalid	Upper 8-bit
	H				L	Invalid	Write	Lower 8-bit
					H	Invalid	Invalid	
H	H	X	X	X	X	X	X	

(3) Reading from VRAM

(3-1) When use 8-bit MPU (MPUSEL = "L", $\overline{\text{BHE}}$ = "H": set)

Table 5

MPU SEL	$\overline{\text{MCS}}$	$\overline{\text{BHE}}$	A <0>	$\overline{\text{RD}}$	Odd Address	Even Address	Valid Data Bus Width of MPU
L	L	H	L	L	Invalid	Read	8-bit
			H		Read	Invalid	
	H		X	H	Invalid	Invalid	
			X	X			

(3-2) When use 16-bit MPU (MPUSEL = "H": set)

Table 6

MPU SEL	$\overline{\text{MCS}}$	$\overline{\text{BHE}}$	A <0>	$\overline{\text{RD}}$	Upper Byte	Lower Byte	Valid Data Bus Width of MPU
H	L	X	X	L	Read	Read	16-bit
	H			H	Invalid	Invalid	
				X			

Note: Avoid setting combination except above, as cause of error action.

X = "L" or "H"

Description of Cycle Steal

Basic Timing

Basic timing of M66271FP is two clocks of OSC (internal clock after dividing OSC1 input).

Assign first clock to accessing from MPU to VRAM and second clock to transferring of display data from VRAM to LCD.

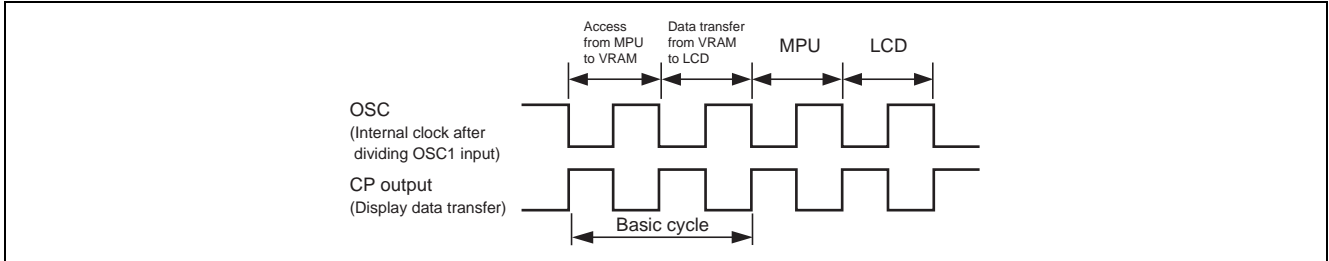

Figure 2 Basic Timing

Operation Cycle of MPU Access (During $\overline{\text{WAIT}}$ Output)

Writing or reading operation for VRAM during cycle steal needs 1 cycle in best case or 3 cycles in worst case, according to the condition of the internal cycle steal at starting access requested from MPU.

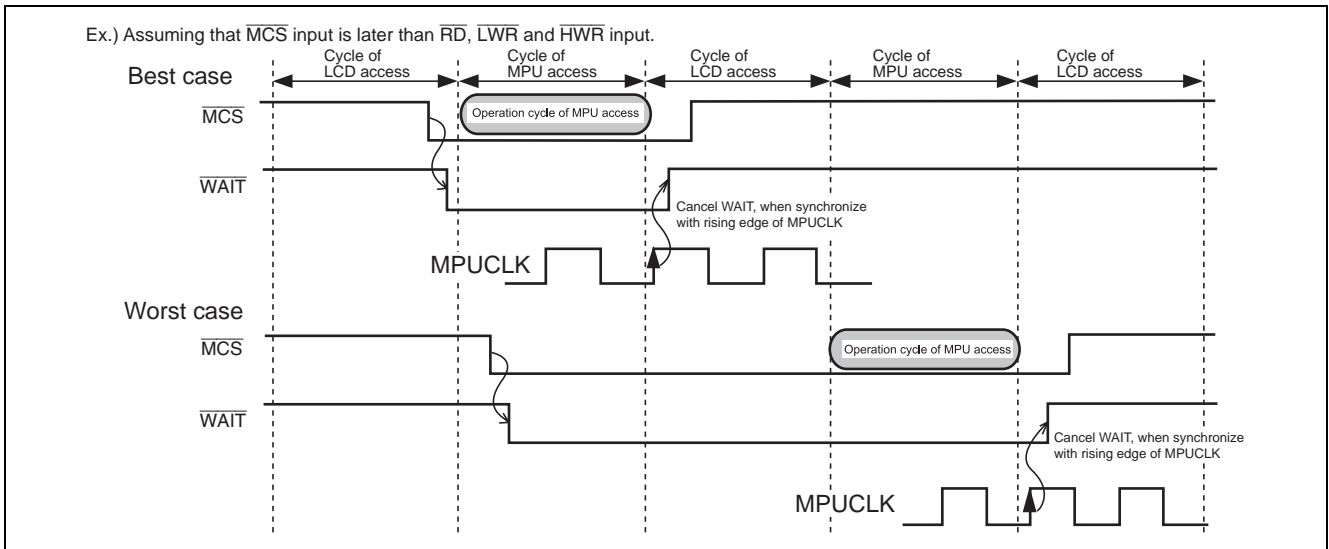

Figure 3 Operation Cycle of MPU Access

Function of Cycle Steal Control

M66271FP has a function for processing data of a line with more efficient. This function access with the cycle steal method as taking $\overline{\text{WAIT}}$ for MPU during the display term with necessity for the display data transfer from built-in VRAM to LCD.

On other side, don't output $\overline{\text{WAIT}}$ for keeping throughput of MPU during the horizontal synchronous term with no necessity for the display data transfer from VRAM to LCD side.

But certainly set a term of accessing with the cycle steal method by CSW register, for controlling an error action near the end of horizontal synchronous term.

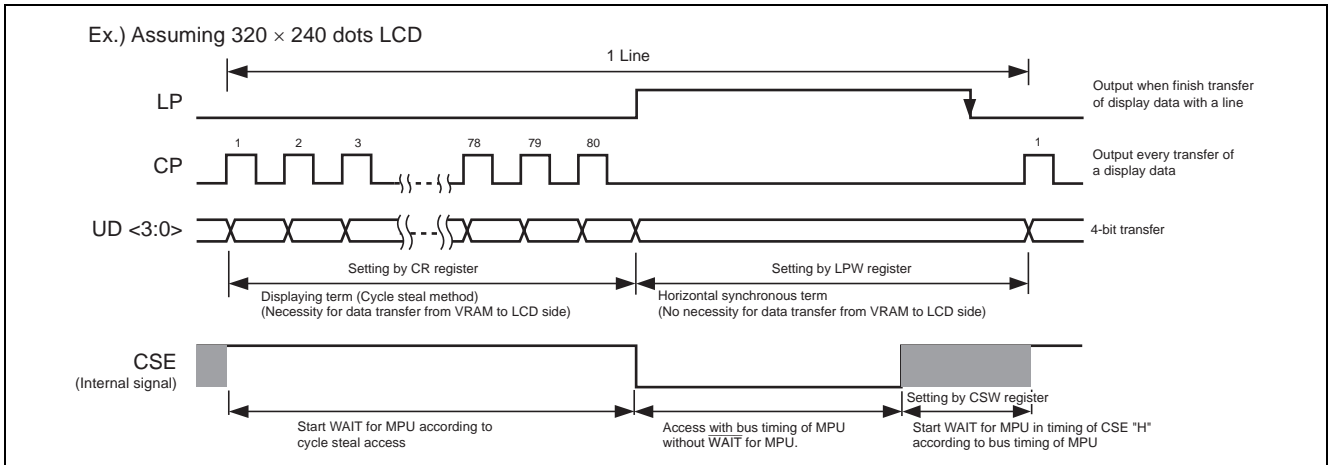

Figure 4 Function of Cycle Steal Control

Handling of Oscillator Pin

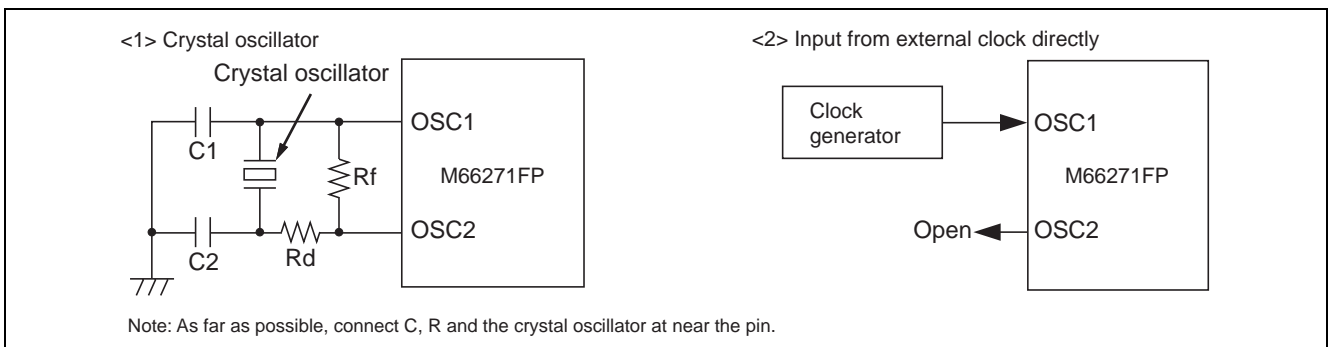

Figure 5 Oscillator Pin

Additional Function for LCD Module Built-in System

As all of the VRAM address in M66271FP are externally opened for addressing VRAM from MPU directly.

When consider the LCD module built-in system, connect pins are increased.

But M66271FP has an additional function for the LCD module built-in system by lessening connect pins.

Outline of the additional function for the LCD module built-in system.

- Interface pins with MPU
15 kinds of interface with MPU: A <4:1>, D <7:0>, $\overline{\text{IOCS}}$, $\overline{\text{LWR}}$, $\overline{\text{RD}}$
- Method of accessing the internal VRAM
Access the internal VRAM through the VRAM address index register (IDX_L, IDX_H) and the data port register (DP) which are used for I/O register.
The following show the process of accessing VRAM.

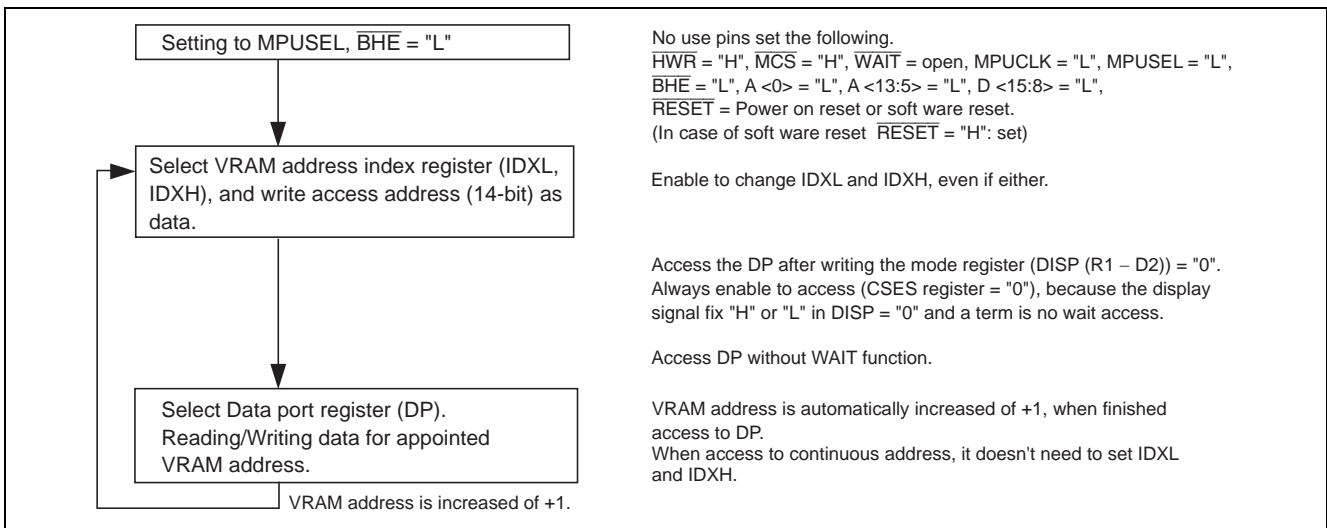

Application

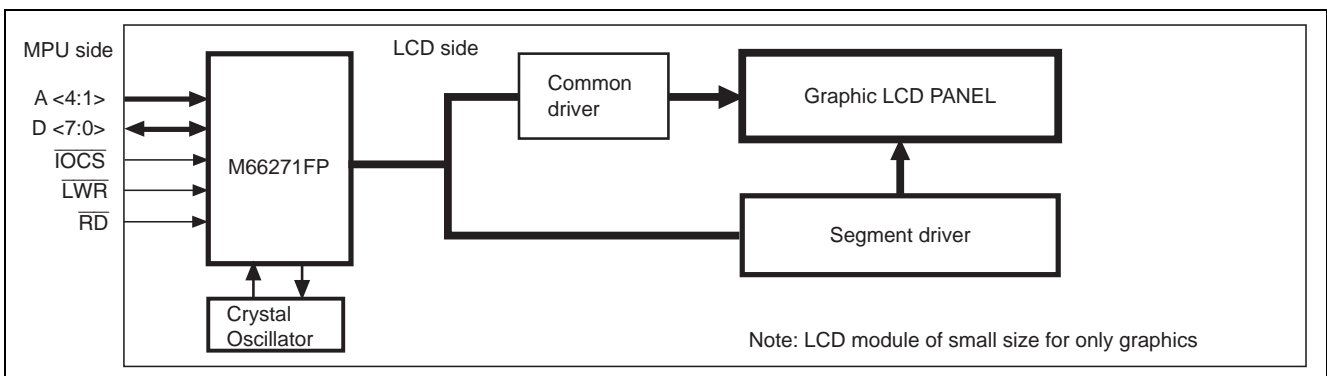

Control Register

M66271FP has 9 kinds of control register.

To set mode from MPU to control register, use \overline{IOCS} , \overline{LWR} , \overline{RD} , A <4:0> and D <7:0>.

(1) Kind of control register

Control Register Table

Kind of Register		Address					Data								Functions of Register	R/W
No.	Name	A4	A3	A2	A1	A0	D7	D6	D5	D4	D3	D2	D1	D0		
R1	Mode register	0	0	0	0	0	CSES	RESET	← OSCC →			DISP	REV	LCDE	D6 to D0 set the basic mode. D7 is the status register of cycle steal state.	R/W D7 = Only "R"
R2	Horizontal display character number register	0	0	0	1	0			← CR →						Set the number of horizontal display characters per line.	W
R3	Horizontal synchronous pulse width register	0	0	1	0	0	← LPW →								Set the pulse width of LP per line.	W
R4	Cycle steal enable width register	0	0	1	1	0	← CSW →								Set the term of cycle steal enable access during horizontal synchronous term.	W
R5	Vertical line number register	0	1	0	0	0	← SLT →								Set the number of display line of vertical direction.	W
R6	Display start address register	0	1	0	1	0	← SAL →								Set the display start address of VRAM.	R/W
R7		0	1	1	0	0			← SAH →						Set lower 8-bit to SAL and upper 6-bit to SAH. Max = 257F _H .	
R8	M cycle variable register	0	1	1	1	0	← MT →								Set the cycle of LCD alternating signal from M.	W
R9	Data port register	1	0	0	0	0	← DP →								Data port register for accessing VRAM through the register.	R/W
R10	VRAM address index register	1	0	0	1	0	← IDXL →								Set the address for accessing VRAM. Set lower 8-bit to IDXL and upper 6-bit to IDXH.	R/W
R11		1	0	1	0	0			← IDXH →						Max = 257F _H And automatically increase in continuous address.	

Note: Data port register (DP) and VRAM address index register (IDXL, IDXH) are exclusive register, when using this IC for the LCD module built-in system.

When RESET, each register is initialize the setting which is assumed LCD size of 320 × 240 dots.

Then, even if each register has not setting, output the signal to LCD side, it is possible to be alternation of LCD.

(2) Description of register

(2-1) Mode register [R1]

Address	R/W	Function		Reset																										
00000	R/W D7 = Only "R"	<table border="1"> <thead> <tr> <th>D7</th> <th>CSES</th> </tr> </thead> <tbody> <tr> <td>0</td> <td>No wait access</td> </tr> <tr> <td>1</td> <td>Cycle steal access</td> </tr> </tbody> </table>		D7	CSES	0	No wait access	1	Cycle steal access	<ul style="list-style-type: none"> Status register for identifying active or inactive in cycle steal function. Set "1" during active with cycle steal function. CSES is for only reading, not for writing. 	0																			
		D7	CSES																											
		0	No wait access																											
		1	Cycle steal access																											
		<table border="1"> <thead> <tr> <th>D6</th> <th>RESET</th> </tr> </thead> <tbody> <tr> <td>0</td> <td>Reset OFF</td> </tr> <tr> <td>1</td> <td>Reset ON</td> </tr> </tbody> </table>		D6	RESET	0	Reset OFF	1	Reset ON	<ul style="list-style-type: none"> Software reset. Surely return to reset off after reset on. 	0																			
		D6	RESET																											
0	Reset OFF																													
1	Reset ON																													
<table border="1"> <thead> <tr> <th colspan="3">OSCC</th> <th rowspan="2">Division of OSC1</th> </tr> <tr> <th>D5</th> <th>D4</th> <th>D3</th> </tr> </thead> <tbody> <tr> <td>0</td> <td>0</td> <td>0</td> <td>1</td> </tr> <tr> <td>0</td> <td>0</td> <td>1</td> <td>1/2 Division</td> </tr> <tr> <td>0</td> <td>1</td> <td>0</td> <td>1/4 Division</td> </tr> <tr> <td>0</td> <td>1</td> <td>1</td> <td>1/8 Division</td> </tr> <tr> <td>1</td> <td>0</td> <td>0</td> <td>1/16 Division</td> </tr> </tbody> </table>		OSCC			Division of OSC1	D5	D4	D3	0	0	0	1	0	0	1	1/2 Division	0	1	0	1/4 Division	0	1	1	1/8 Division	1	0	0	1/16 Division	<ul style="list-style-type: none"> Set the division of OSC clock for internal operation from OSC1 input pin. When reset, OSCC = 000, OSC1 clock doesn't divide. Don't set except left table. 	000
OSCC			Division of OSC1																											
D5	D4	D3																												
0	0	0	1																											
0	0	1	1/2 Division																											
0	1	0	1/4 Division																											
0	1	1	1/8 Division																											
1	0	0	1/16 Division																											
<table border="1"> <thead> <tr> <th>D2</th> <th>DISP</th> </tr> </thead> <tbody> <tr> <td>0</td> <td>Display OFF</td> </tr> <tr> <td>1</td> <td>Display ON</td> </tr> </tbody> </table>		D2	DISP	0	Display OFF	1	Display ON	<ul style="list-style-type: none"> Control the displaying ON/OFF of LCD. When reset, DISP = 0, set display OFF. REV (D1) set "1", and when DISP = "0" display data UD <3:0> output "1" in reversal mode. 	0																					
D2	DISP																													
0	Display OFF																													
1	Display ON																													
<table border="1"> <thead> <tr> <th>D1</th> <th>REV</th> </tr> </thead> <tbody> <tr> <td>0</td> <td>Normal display</td> </tr> <tr> <td>1</td> <td>Reversal display</td> </tr> </tbody> </table>		D1	REV	0	Normal display	1	Reversal display	<ul style="list-style-type: none"> Control normal/reversal of LCD display. When reset, REV = 0, set normal display. In using LCD of permeation method, REV = "1" has effect. 	0																					
D1	REV																													
0	Normal display																													
1	Reversal display																													
<table border="1"> <thead> <tr> <th>D0</th> <th>LCDE</th> </tr> </thead> <tbody> <tr> <td>0</td> <td>LCDENB = "0" output</td> </tr> <tr> <td>1</td> <td>LCDENB = "1" output</td> </tr> </tbody> </table>		D0	LCDE	0	LCDENB = "0" output	1	LCDENB = "1" output	<ul style="list-style-type: none"> Set the output data from LCDENB output pin. When reset, LCDE = 0, LCDENB output "0" (Vss potential). This function is prepared for controlling the voltage of LCD. <p>When the power supply is ON after finish each register setting, LCDE = "1", supply voltage of LCD. Conversely for setting power supply OFF, first LCDE = "0", the voltage of LCD is OFF. Therefore enable to prevent LCD from being unusual voltage as DC. This function use for satisfy the need of LCD.</p>	0																					
D0	LCDE																													
0	LCDENB = "0" output																													
1	LCDENB = "1" output																													

(2-2) Horizontal display characters number register [R2]

Address	R/W	Function								Reset																																																																									
00010	W	<table border="1"> <thead> <tr> <th colspan="8">CR</th> <th rowspan="2">Character Number</th> <th rowspan="2">Display Dot Number</th> </tr> <tr> <th>D7</th> <th>D6</th> <th>D5</th> <th>D4</th> <th>D3</th> <th>D2</th> <th>D1</th> <th>D0</th> </tr> </thead> <tbody> <tr> <td></td> <td></td> <td>0</td> <td>0</td> <td>0</td> <td>0</td> <td>0</td> <td>0</td> <td>0</td> <td>—</td> <td>—</td> </tr> <tr> <td></td> <td></td> <td>0</td> <td>0</td> <td>0</td> <td>0</td> <td>0</td> <td>0</td> <td>1</td> <td>1</td> <td>8</td> </tr> <tr> <td></td> <td></td> <td>0</td> <td>0</td> <td>0</td> <td>0</td> <td>1</td> <td>0</td> <td></td> <td>2</td> <td>16</td> </tr> <tr> <td></td> <td></td> <td colspan="6" style="text-align: center;">↓</td> <td></td> <td>↓</td> <td>↓</td> </tr> <tr> <td></td> <td></td> <td>1</td> <td>1</td> <td>1</td> <td>1</td> <td>1</td> <td>1</td> <td>1</td> <td>63</td> <td>504</td> </tr> </tbody> </table>								CR								Character Number	Display Dot Number	D7	D6	D5	D4	D3	D2	D1	D0			0	0	0	0	0	0	0	—	—			0	0	0	0	0	0	1	1	8			0	0	0	0	1	0		2	16			↓							↓	↓			1	1	1	1	1	1	1	63	504	28 _H
CR								Character Number	Display Dot Number																																																																										
D7	D6	D5	D4	D3	D2	D1	D0																																																																												
		0	0	0	0	0	0	0	—	—																																																																									
		0	0	0	0	0	0	1	1	8																																																																									
		0	0	0	0	1	0		2	16																																																																									
		↓							↓	↓																																																																									
		1	1	1	1	1	1	1	63	504																																																																									
<ul style="list-style-type: none"> The number of horizontal display characters per line can set to the extent of Max = 504 dots (= 63 characters) When reset, CR = "28_H" (= 40 characters = 320 dots) 																																																																																			

Note: Definition of the number of display characters.

The number of display characters means data which is corresponding with 1 byte of VRAM.

In case of binary, 1 bit of VRAM corresponds to 1 dot of display, then 1 character means 8 dots of display.

(2-3) Horizontal synchronous pulse width register [R3]

Address	R/W	Function								Reset																																																																			
00100	W	<table border="1"> <thead> <tr> <th colspan="8">LPW</th> <th rowspan="2">Character Number</th> </tr> <tr> <th>D7</th> <th>D6</th> <th>D5</th> <th>D4</th> <th>D3</th> <th>D2</th> <th>D1</th> <th>D0</th> </tr> </thead> <tbody> <tr> <td></td> <td></td> <td>0</td> <td>0</td> <td>0</td> <td>0</td> <td>0</td> <td>0</td> <td>0</td> <td>—</td> </tr> <tr> <td></td> <td></td> <td>0</td> <td>0</td> <td>0</td> <td>0</td> <td>0</td> <td>0</td> <td>1</td> <td>1</td> </tr> <tr> <td></td> <td></td> <td>0</td> <td>0</td> <td>0</td> <td>0</td> <td>0</td> <td>1</td> <td>0</td> <td>2</td> </tr> <tr> <td></td> <td></td> <td colspan="6" style="text-align: center;">↓</td> <td></td> <td>↓</td> </tr> <tr> <td></td> <td></td> <td>1</td> <td>1</td> <td>1</td> <td>1</td> <td>1</td> <td>1</td> <td>1</td> <td>255</td> </tr> </tbody> </table>								LPW								Character Number	D7	D6	D5	D4	D3	D2	D1	D0			0	0	0	0	0	0	0	—			0	0	0	0	0	0	1	1			0	0	0	0	0	1	0	2			↓							↓			1	1	1	1	1	1	1	255	01 _H
LPW								Character Number																																																																					
D7	D6	D5	D4	D3	D2	D1	D0																																																																						
		0	0	0	0	0	0	0	—																																																																				
		0	0	0	0	0	0	1	1																																																																				
		0	0	0	0	0	1	0	2																																																																				
		↓							↓																																																																				
		1	1	1	1	1	1	1	255																																																																				
<ul style="list-style-type: none"> Set the length of horizontal synchronous pulse width which appeared per line in character unit. Horizontal synchronous pulse output from LP output pin, and use for changing serial/parallel of displaying data. Adjusting this pulse width is possible to set frame frequency the fittest value. And the actual LP output pulse is (LPW setting value – 1CP) in consideration of timing with CP output. When reset, LPW = "01_H" (= 1 character) 																																																																													

(2-4) Cycle steal enable width register [R4]

Address	R/W	Function	Reset																																																														
00110	W	<table border="1"> <thead> <tr> <th colspan="8">CSW</th> <th rowspan="2">Character Number</th> </tr> <tr> <th>D7</th> <th>D6</th> <th>D5</th> <th>D4</th> <th>D3</th> <th>D2</th> <th>D1</th> <th>D0</th> </tr> </thead> <tbody> <tr> <td>0</td> <td>0</td> <td>0</td> <td>0</td> <td>0</td> <td>0</td> <td>0</td> <td>0</td> <td>—</td> </tr> <tr> <td>0</td> <td>0</td> <td>0</td> <td>0</td> <td>0</td> <td>0</td> <td>0</td> <td>1</td> <td>1</td> </tr> <tr> <td>0</td> <td>0</td> <td>0</td> <td>0</td> <td>0</td> <td>0</td> <td>1</td> <td>0</td> <td>2</td> </tr> <tr> <td colspan="8" style="text-align: center;">↓</td> <td style="text-align: center;">↓</td> </tr> <tr> <td>1</td> <td>1</td> <td>1</td> <td>1</td> <td>1</td> <td>1</td> <td>1</td> <td>1</td> <td>255</td> </tr> </tbody> </table> <ul style="list-style-type: none"> During the horizontal synchronous term, set term of access by cycle steal method in character number unit. Setting value of CSW sets below LPW value. When reset, CSW = "00_H" <p>Note: Be careful with first and second byte of display data UD <3:0> output indefinite data when setting value of CSW is still reset (00_H). Surely CSW set over 01_H. (When select 8-bit MPU, 1 byte is indefinite. When 16-bit and SAL: D <0> = 0, 2 byte are indefinite. When 16-bit and SAL: D <0> = 1, 1 byte is indefinite.)</p>	CSW								Character Number	D7	D6	D5	D4	D3	D2	D1	D0	0	0	0	0	0	0	0	0	—	0	0	0	0	0	0	0	1	1	0	0	0	0	0	0	1	0	2	↓								↓	1	1	1	1	1	1	1	1	255	00 _H
CSW								Character Number																																																									
D7	D6	D5	D4	D3	D2	D1	D0																																																										
0	0	0	0	0	0	0	0	—																																																									
0	0	0	0	0	0	0	1	1																																																									
0	0	0	0	0	0	1	0	2																																																									
↓								↓																																																									
1	1	1	1	1	1	1	1	255																																																									

(2-5) Vertical line number register [R5]

Address	R/W	Function	Reset																																																														
01000	W	<table border="1"> <thead> <tr> <th colspan="8">SLT</th> <th rowspan="2">Vertical Line Number</th> </tr> <tr> <th>D7</th> <th>D6</th> <th>D5</th> <th>D4</th> <th>D3</th> <th>D2</th> <th>D1</th> <th>D0</th> </tr> </thead> <tbody> <tr> <td>0</td> <td>0</td> <td>0</td> <td>0</td> <td>0</td> <td>0</td> <td>0</td> <td>0</td> <td>—</td> </tr> <tr> <td>0</td> <td>0</td> <td>0</td> <td>0</td> <td>0</td> <td>0</td> <td>0</td> <td>1</td> <td>1</td> </tr> <tr> <td>0</td> <td>0</td> <td>0</td> <td>0</td> <td>0</td> <td>0</td> <td>1</td> <td>0</td> <td>2</td> </tr> <tr> <td colspan="8" style="text-align: center;">↓</td> <td style="text-align: center;">↓</td> </tr> <tr> <td>1</td> <td>1</td> <td>1</td> <td>1</td> <td>1</td> <td>1</td> <td>1</td> <td>1</td> <td>255</td> </tr> </tbody> </table> <ul style="list-style-type: none"> SLT combine the setting of display driving duty of LCD. Setting of SLT is sure to adjust to the number of display line of LCD. When reset, SLT = "F0_H" (= 240 lines). 	SLT								Vertical Line Number	D7	D6	D5	D4	D3	D2	D1	D0	0	0	0	0	0	0	0	0	—	0	0	0	0	0	0	0	1	1	0	0	0	0	0	0	1	0	2	↓								↓	1	1	1	1	1	1	1	1	255	F0 _H
SLT								Vertical Line Number																																																									
D7	D6	D5	D4	D3	D2	D1	D0																																																										
0	0	0	0	0	0	0	0	—																																																									
0	0	0	0	0	0	0	1	1																																																									
0	0	0	0	0	0	1	0	2																																																									
↓								↓																																																									
1	1	1	1	1	1	1	1	255																																																									

(2-6) Display start address register [R6, R7]

Address	R/W	Function	Reset																																																																																																																							
01010 SAL	R/W	<table border="1"> <thead> <tr> <th colspan="8">SAH</th> <th colspan="8">SAL</th> <th>Display Start Address</th> </tr> <tr> <th>D7</th><th>D6</th><th>D5</th><th>D4</th><th>D3</th><th>D2</th><th>D1</th><th>D0</th> <th>D7</th><th>D6</th><th>D5</th><th>D4</th><th>D3</th><th>D2</th><th>D1</th><th>D0</th> <th></th> </tr> </thead> <tbody> <tr> <td></td><td></td><td>0</td><td>0</td><td>0</td><td>0</td><td>0</td><td>0</td> <td>0</td><td>0</td><td>0</td><td>0</td><td>0</td><td>0</td><td>0</td><td>0</td> <td>0000_H</td> </tr> <tr> <td></td><td></td><td>0</td><td>0</td><td>0</td><td>0</td><td>0</td><td>0</td> <td>0</td><td>0</td><td>0</td><td>0</td><td>0</td><td>0</td><td>0</td><td>1</td> <td>0001_H</td> </tr> <tr> <td></td><td></td><td>0</td><td>0</td><td>0</td><td>0</td><td>0</td><td>0</td> <td>0</td><td>0</td><td>0</td><td>0</td><td>0</td><td>0</td><td>1</td><td>0</td> <td>0002_H</td> </tr> <tr> <td></td><td></td><td></td><td></td><td></td><td></td><td></td><td></td> <td></td><td></td><td></td><td></td><td></td><td></td><td></td><td></td> <td>↓</td> </tr> <tr> <td></td><td></td><td>1</td><td>0</td><td>0</td><td>1</td><td>0</td><td>1</td> <td>0</td><td>1</td><td>1</td><td>1</td><td>1</td><td>1</td><td>1</td><td>1</td> <td>257F_H</td> </tr> </tbody> </table>	SAH								SAL								Display Start Address	D7	D6	D5	D4	D3	D2	D1	D0	D7	D6	D5	D4	D3	D2	D1	D0				0	0	0	0	0	0	0	0	0	0	0	0	0	0	0000 _H			0	0	0	0	0	0	0	0	0	0	0	0	0	1	0001 _H			0	0	0	0	0	0	0	0	0	0	0	0	1	0	0002 _H																	↓			1	0	0	1	0	1	0	1	1	1	1	1	1	1	257F _H	0000 _H
SAH								SAL								Display Start Address																																																																																																										
D7	D6	D5	D4	D3	D2	D1	D0	D7	D6	D5	D4	D3	D2	D1	D0																																																																																																											
		0	0	0	0	0	0	0	0	0	0	0	0	0	0	0000 _H																																																																																																										
		0	0	0	0	0	0	0	0	0	0	0	0	0	1	0001 _H																																																																																																										
		0	0	0	0	0	0	0	0	0	0	0	0	1	0	0002 _H																																																																																																										
																↓																																																																																																										
		1	0	0	1	0	1	0	1	1	1	1	1	1	1	257F _H																																																																																																										
01100 SAH		<ul style="list-style-type: none"> D6 and D7 output "0" when read SAH. It is possible to set display start address to the extent of 257F_H (= 9600 address). Don't set over 2580_H. When reset, SAL and SAH = "0000_H" Display start address is established by the writing data to SAH register. Even if only change SAL, surely set SAH after SAL. When select 8-bit MPU, start address set in SAL <D7 to D0> + SAH <D5 to D0>. When select 16-bit MPU, start address set in SAL <D7 to D1>+ SAH <D5 to D0>. Even it selecting 16-bit MPU, enable to set display start address in character unit. In case the display reading data from VRAM start at D <15:12>, set SAL <D0> = "0", and if start at D <7:4>, set SAL <D0> = "1". (Refer to figure 8) 																																																																																																																								

(2-7) M cycle variable register [R8]

Address	R/W	Function	Reset																																																														
01110	W	<table border="1"> <thead> <tr> <th colspan="8">MT</th> <th rowspan="2">Cycle of M</th> </tr> <tr> <th>D7</th><th>D6</th><th>D5</th><th>D4</th><th>D3</th><th>D2</th><th>D1</th><th>D0</th> </tr> </thead> <tbody> <tr> <td>0</td><td>0</td><td>0</td><td>0</td><td>0</td><td>0</td><td>0</td><td>0</td> <td>Toggle change at every 1 frame.</td> </tr> <tr> <td>0</td><td>0</td><td>0</td><td>0</td><td>0</td><td>0</td><td>0</td><td>1</td> <td>Toggle change at every 1 line (1LP).</td> </tr> <tr> <td>0</td><td>0</td><td>0</td><td>0</td><td>0</td><td>0</td><td>1</td><td>0</td> <td>Toggle change at every 2 lines.</td> </tr> <tr> <td></td><td></td><td></td><td></td><td></td><td></td><td></td><td></td> <td>↓</td> </tr> <tr> <td>1</td><td>1</td><td>1</td><td>1</td><td>1</td><td>1</td><td>1</td><td>1</td> <td>Toggle change at every 255 lines.</td> </tr> </tbody> </table>	MT								Cycle of M	D7	D6	D5	D4	D3	D2	D1	D0	0	0	0	0	0	0	0	0	Toggle change at every 1 frame.	0	0	0	0	0	0	0	1	Toggle change at every 1 line (1LP).	0	0	0	0	0	0	1	0	Toggle change at every 2 lines.									↓	1	1	1	1	1	1	1	1	Toggle change at every 255 lines.	00 _H
MT								Cycle of M																																																									
D7	D6	D5	D4	D3	D2	D1	D0																																																										
0	0	0	0	0	0	0	0	Toggle change at every 1 frame.																																																									
0	0	0	0	0	0	0	1	Toggle change at every 1 line (1LP).																																																									
0	0	0	0	0	0	1	0	Toggle change at every 2 lines.																																																									
								↓																																																									
1	1	1	1	1	1	1	1	Toggle change at every 255 lines.																																																									
		<ul style="list-style-type: none"> Set the cycle of M. In case of MT = 01_H, M repeat reversal (toggle) at every 1 line (at every 1 count of LP). When reset, MT = "00_H", toggle M signal at every 1 frame. We recommend this register set suitable value for user's LCD. 																																																															

(2-8) Data port register [R9]

Address	R/W	Function	Reset																										
10000	R/W	<table border="1"> <thead> <tr> <th colspan="8">DP</th> <th rowspan="2">Data Port (8-bit)</th> </tr> <tr> <th>D7</th><th>D6</th><th>D5</th><th>D4</th><th>D3</th><th>D2</th><th>D1</th><th>D0</th> </tr> </thead> <tbody> <tr> <td></td><td></td><td></td><td></td><td></td><td></td><td></td><td></td> <td></td> </tr> </tbody> </table>	DP								Data Port (8-bit)	D7	D6	D5	D4	D3	D2	D1	D0										XX _H (indefinite)
DP								Data Port (8-bit)																					
D7	D6	D5	D4	D3	D2	D1	D0																						
		<ul style="list-style-type: none"> Exclusive data port register for the LCD module built-in system. Reading or writing 8-bit data between MPU and VRAM through this register. VRAM address index register (IDX_L, IDX_H) is increased of +1, when finished access to DP. Output indefinite data when reset. 																											

Relation between Address of VRAM and LCD Display

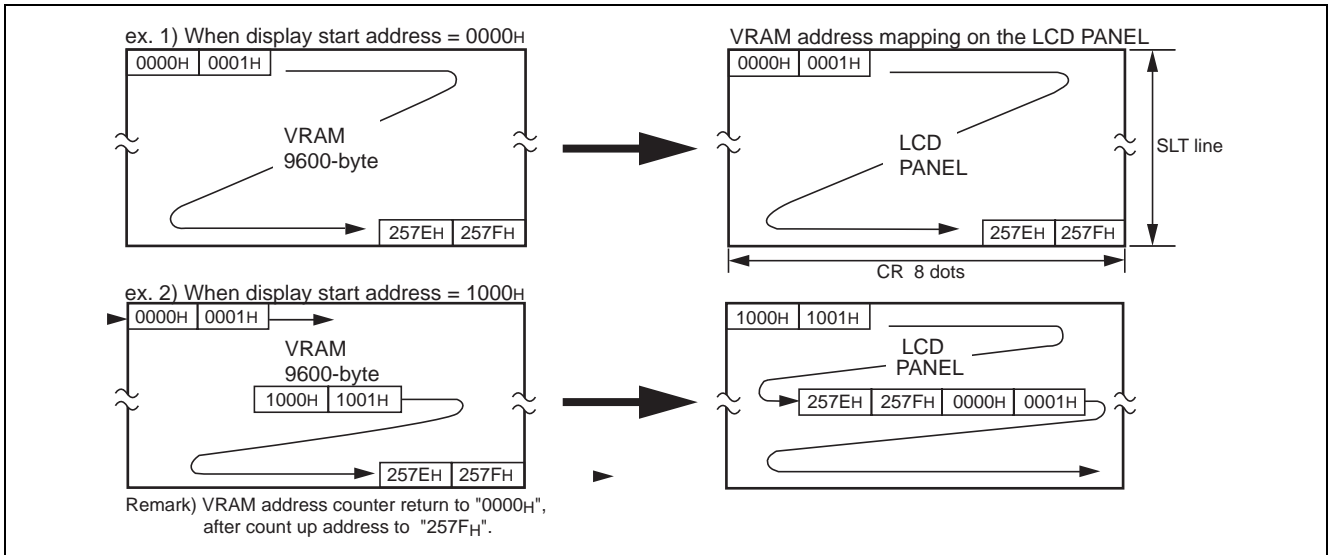

Figure 7 Relation between Address of VRAM and LCD Display

Relation between VRAM Data, LCD Display and Display Start Address Register

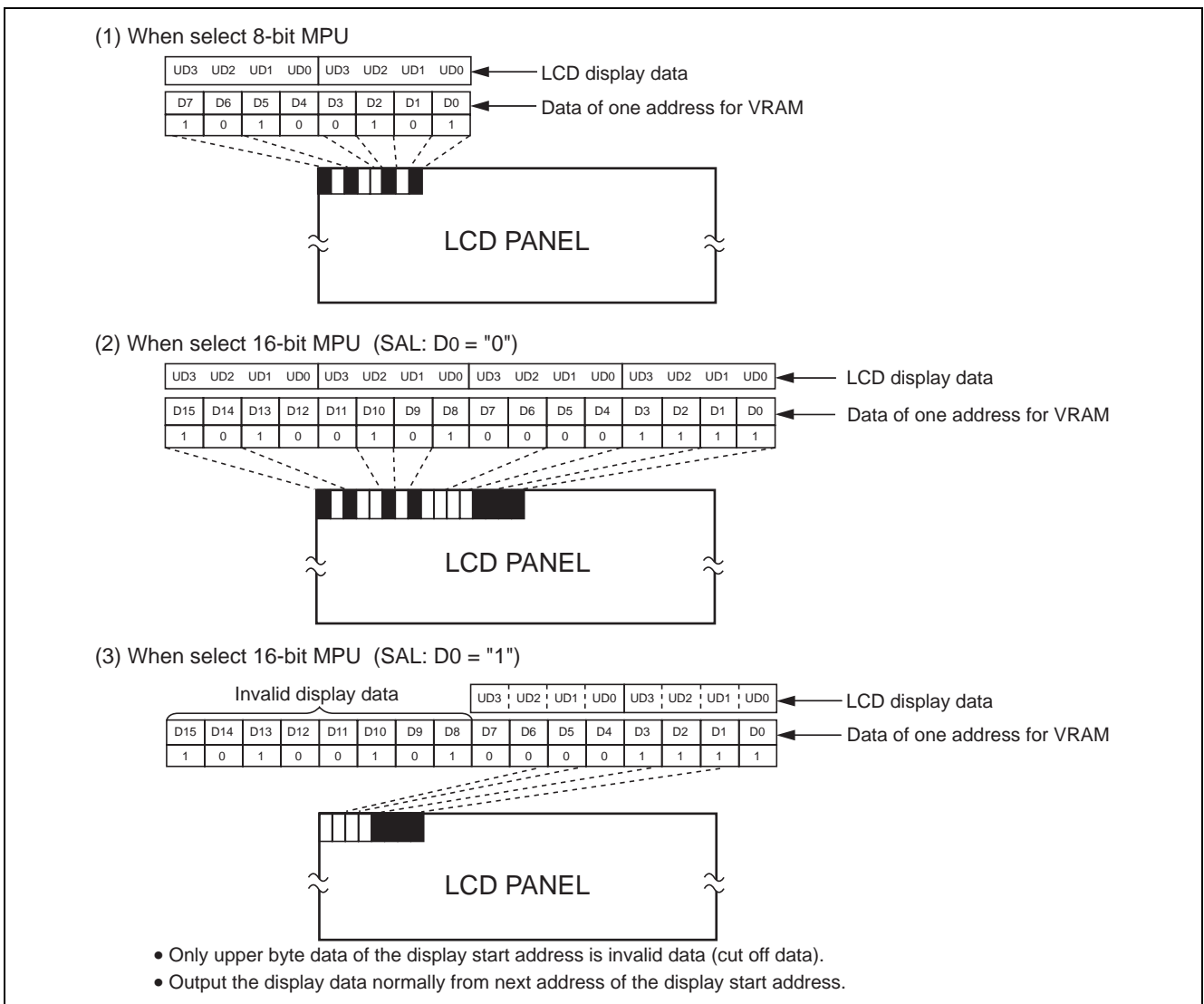
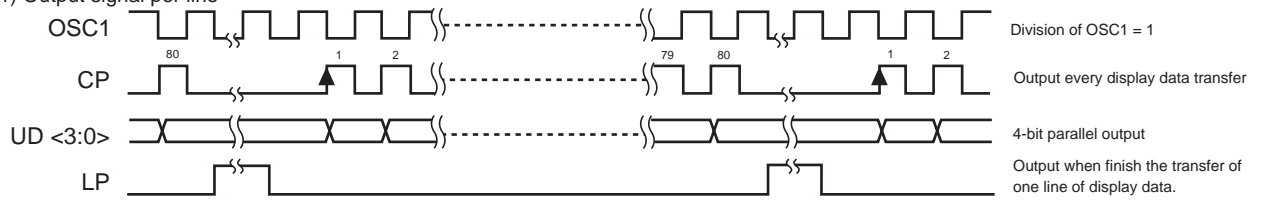

Figure 8 Relation between VRAM Data, LCD Display and Display Start Address Register

Output Signal of LCD Side

Ex.) Assuming 320 × 240 dots LCD
 (In setting of CR = 40 characters, LPW = 2 characters, SLT = 240 lines, OSCC = 1 division, MT = 1 toggle per line)

(1) Output signal per line



(2) Output signal per frame

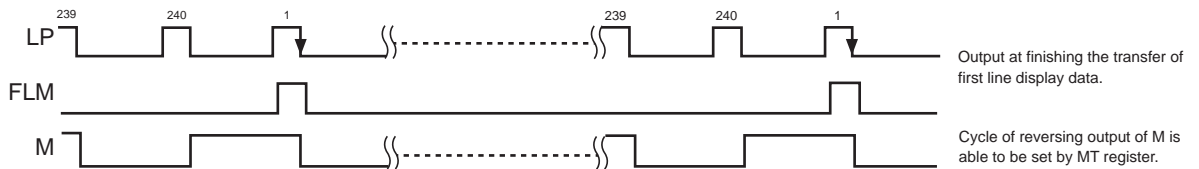

(3) LCDENB output signal

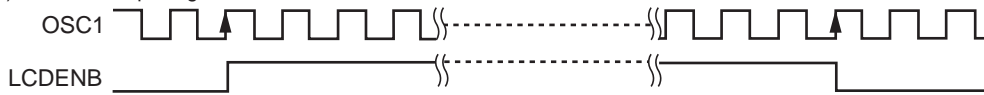

(4) Reset-1st line of 1st frame

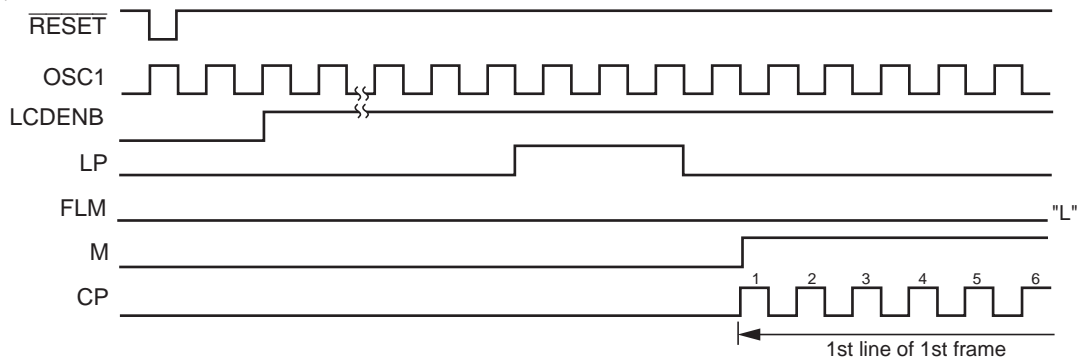

(5) 1st line-2nd line

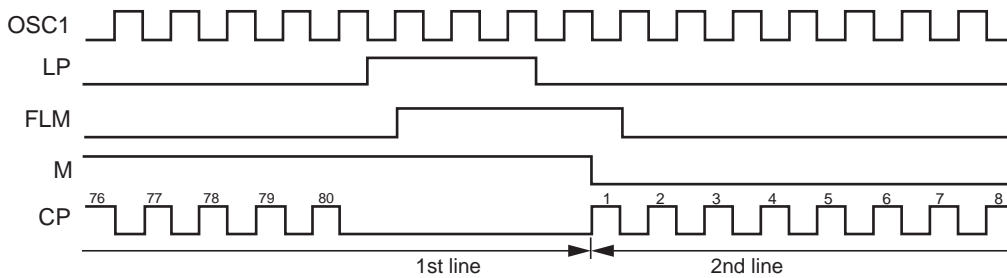

(6) 240th line of 1st frame-1st line of 2nd frame

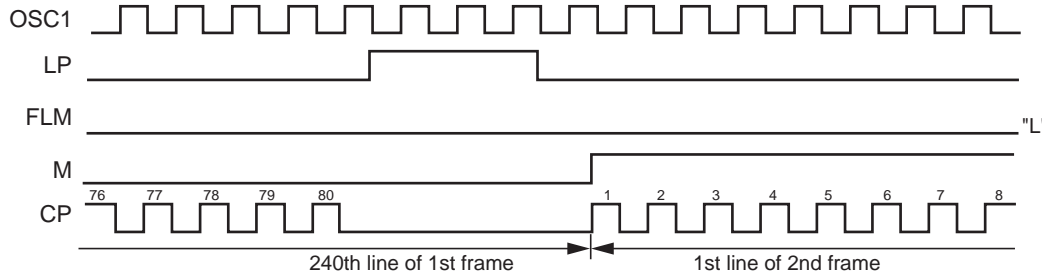

Timing Diagram

(1) Write to Control Register ($\overline{RD} = "H"$)

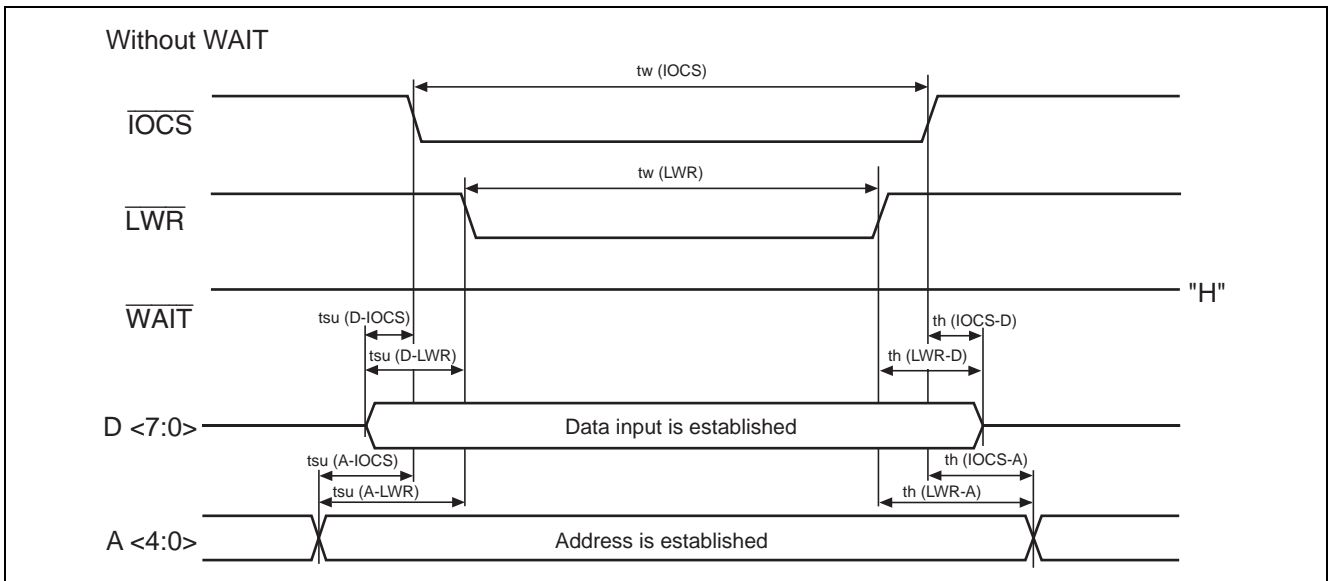

(2) Read from Control Register ($\overline{LWR} = "H"$)

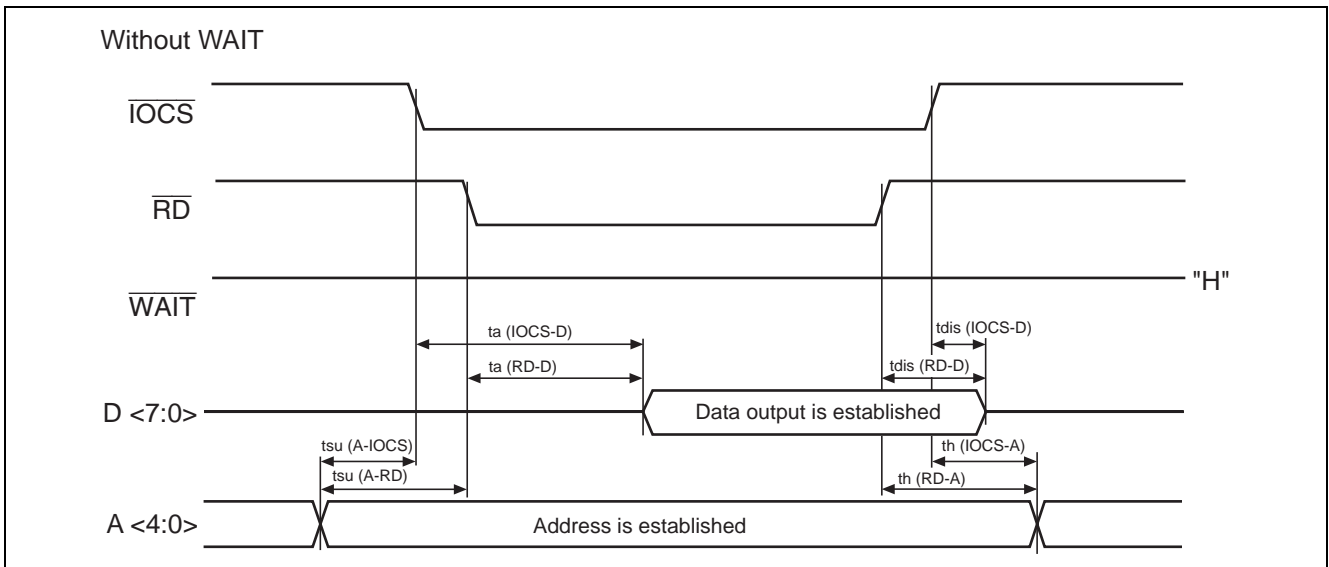

Note: 1. Writing/Reading operation for the control register is performed during overlapping \overline{IOCS} and (\overline{LWR} or \overline{RD}). Limits of \overline{IOCS} , \overline{LWR} and \overline{RD} are prescribed by the input signal of last change to "L" in starting access, and by the input signal of first change to "H" in ending access.

(3) Write to VRAM ($\overline{RD} = "H"$)

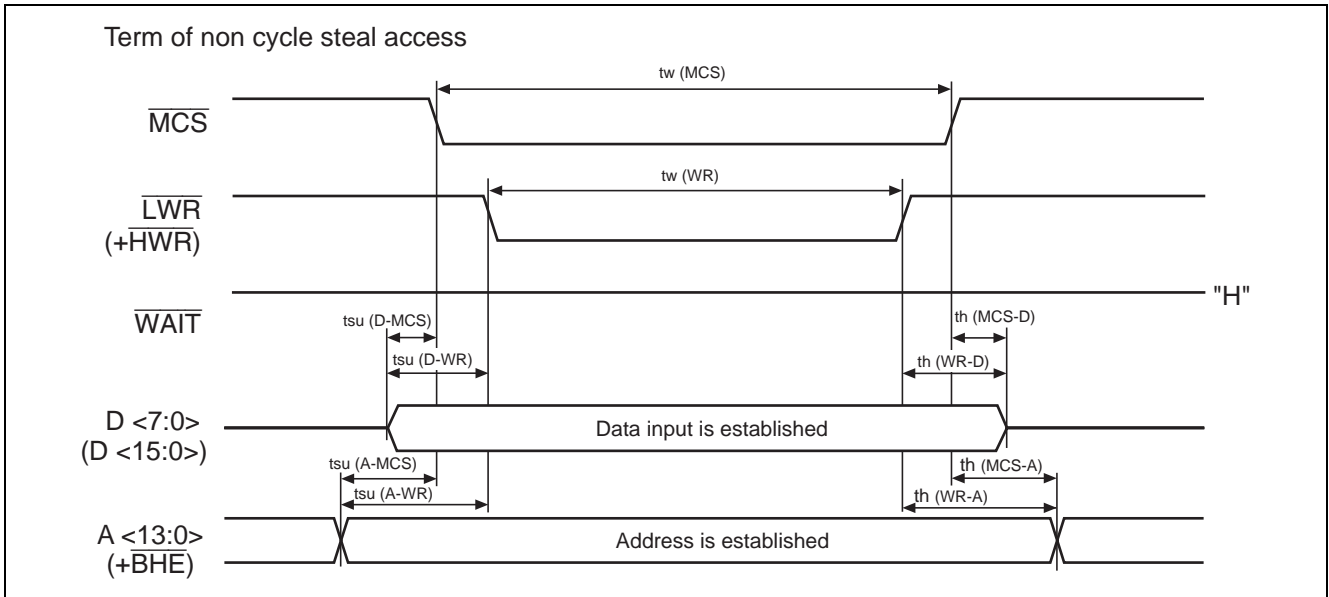

(4) Read from VRAM ($\overline{LWR}, \overline{HWR} = "H"$)

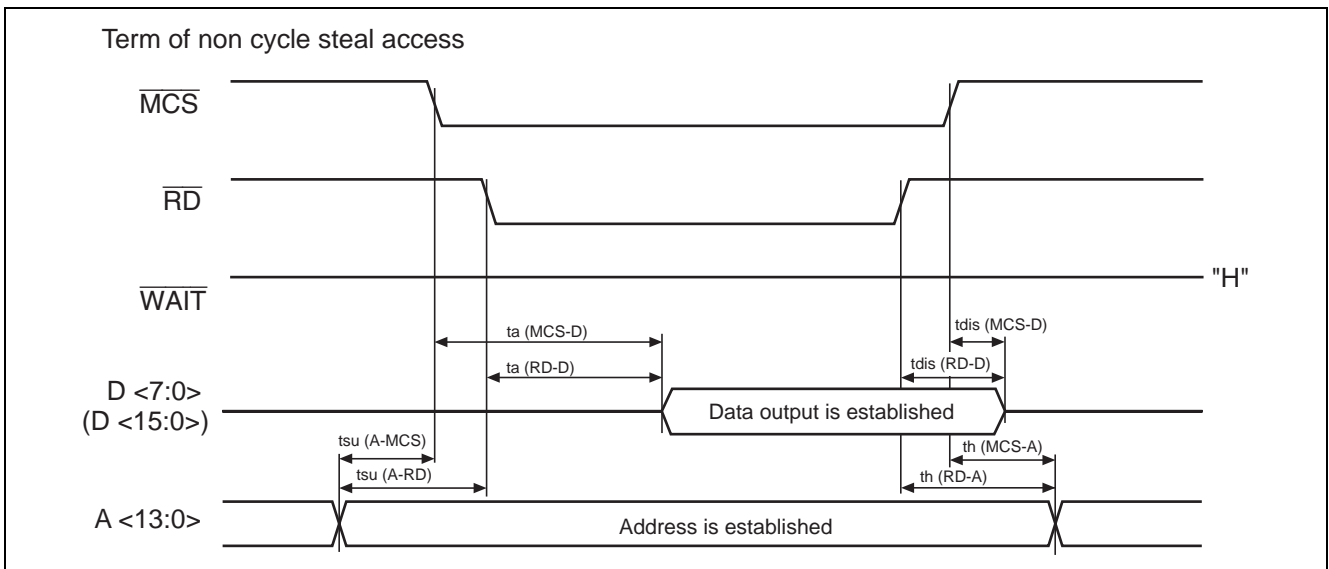

Note: 2. Writing/Reading operation for VRAM during non cycle steal access is performed during overlapping \overline{MCS} and [\overline{LWR} (+ \overline{HWR}) or \overline{RD}].

Limits of \overline{MCS} , \overline{LWR} (+ \overline{HWR}) and \overline{RD} are prescribed by the input signal of last change to "L" in starting access, and by the input signal of first change to "H" in ending access.

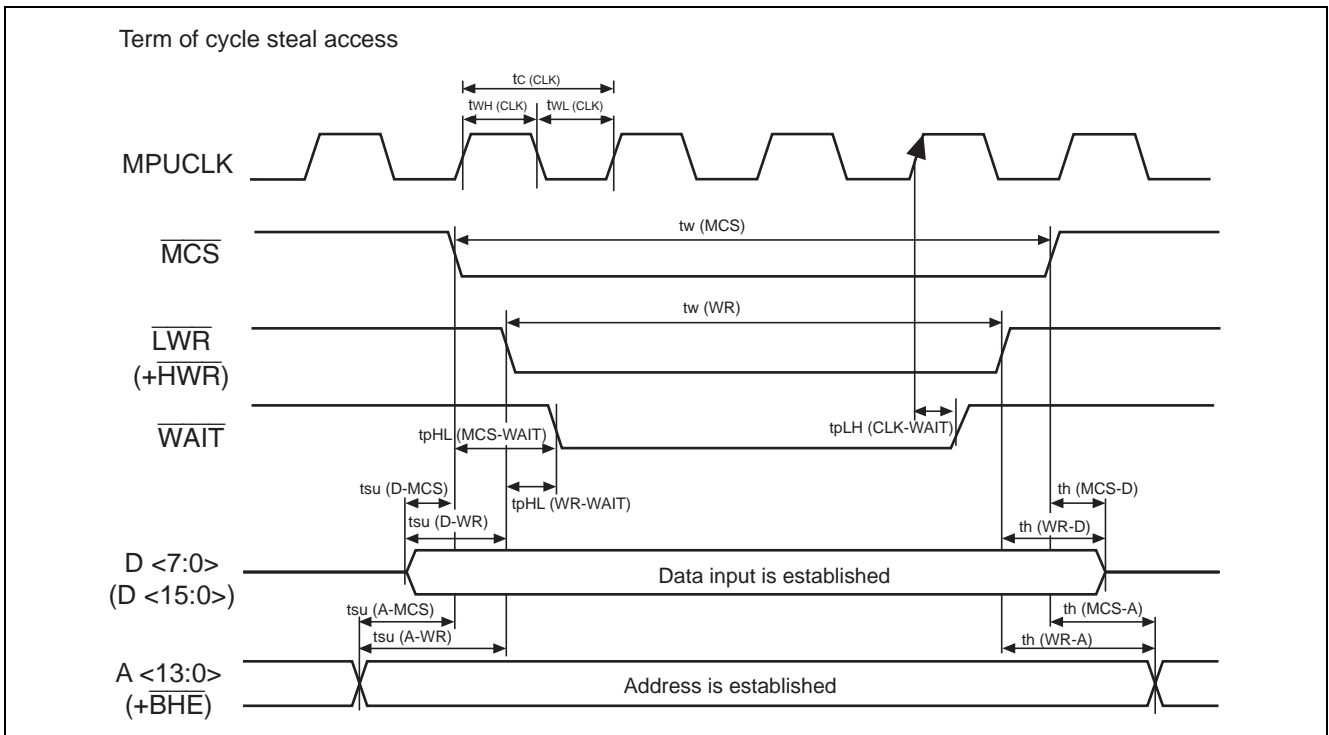
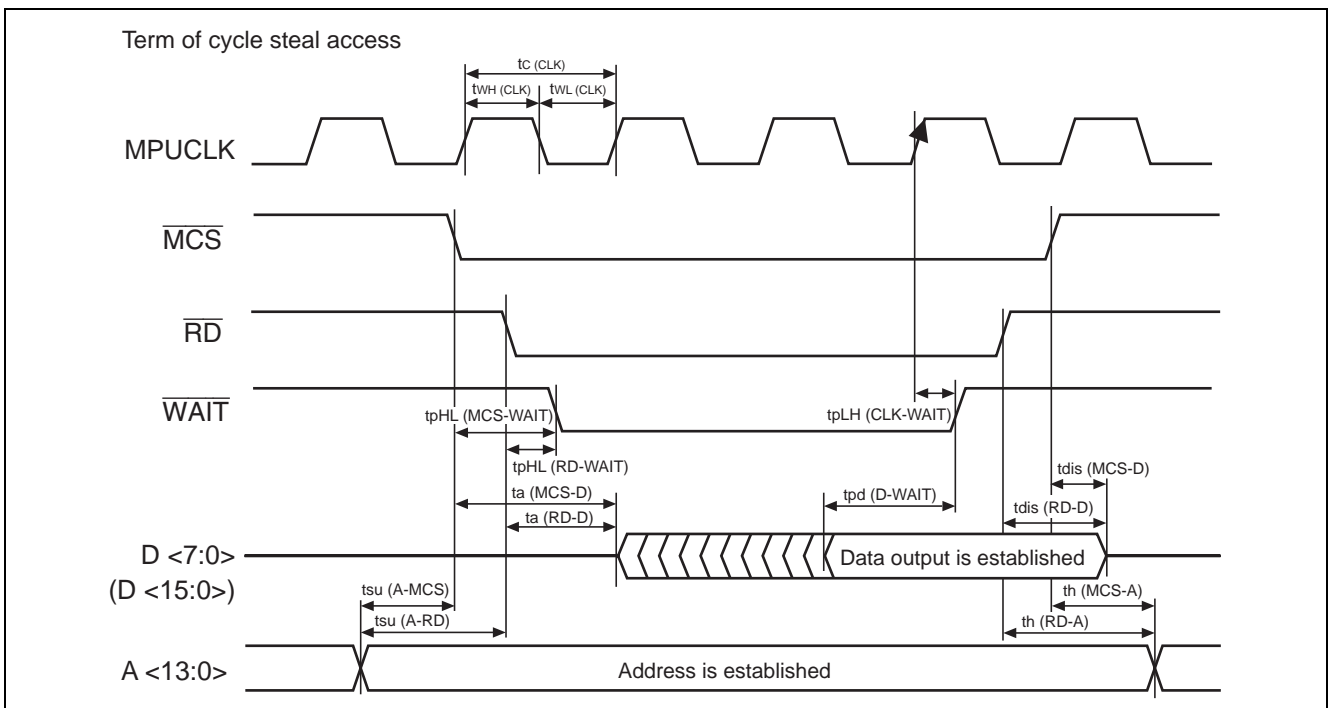
(5) Write to VRAM ($\overline{RD} = "H"$)(6) Read from VRAM ($\overline{LWR}, \overline{HWR} = "H"$)

Notes: 3. Reading/writing operation for VRAM during cycle steal needs 1 t_c (Internal) in best case or 3 t_c (Internal) in worst case, according to the condition of the internal cycle steal at starting access requested from MPU.

t_c (Internal) = Clock cycle time after setting division of OSC1.

Data output D in reading is established before changing \overline{WAIT} to "H".

4. Limits of \overline{MCS} , \overline{LWR} (+ \overline{HWR}) and \overline{RD} are prescribed by the input signal of last change to "L" in starting access, and by the input signal of first change to "H" in ending access.

5. Always once return \overline{MCS} , \overline{LWR} (+ \overline{HWR}) or \overline{RD} to "H" after canceling \overline{WAIT} output.

In case of latching "L", as don't output next \overline{WAIT} , this is cause of error action.

(7) Interface Timing with LCD (OSCC = 1 division: set)

(When OSCC = 1 division, OSC clock for internal operation = OSC1 input.)

1. Transfer of LCD display data

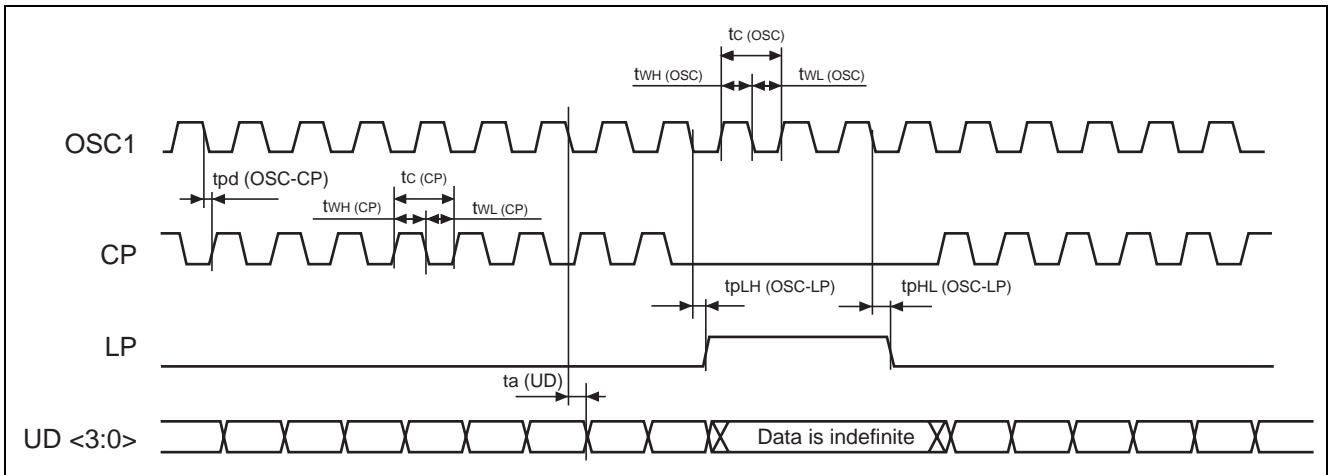

2. LCD control signal

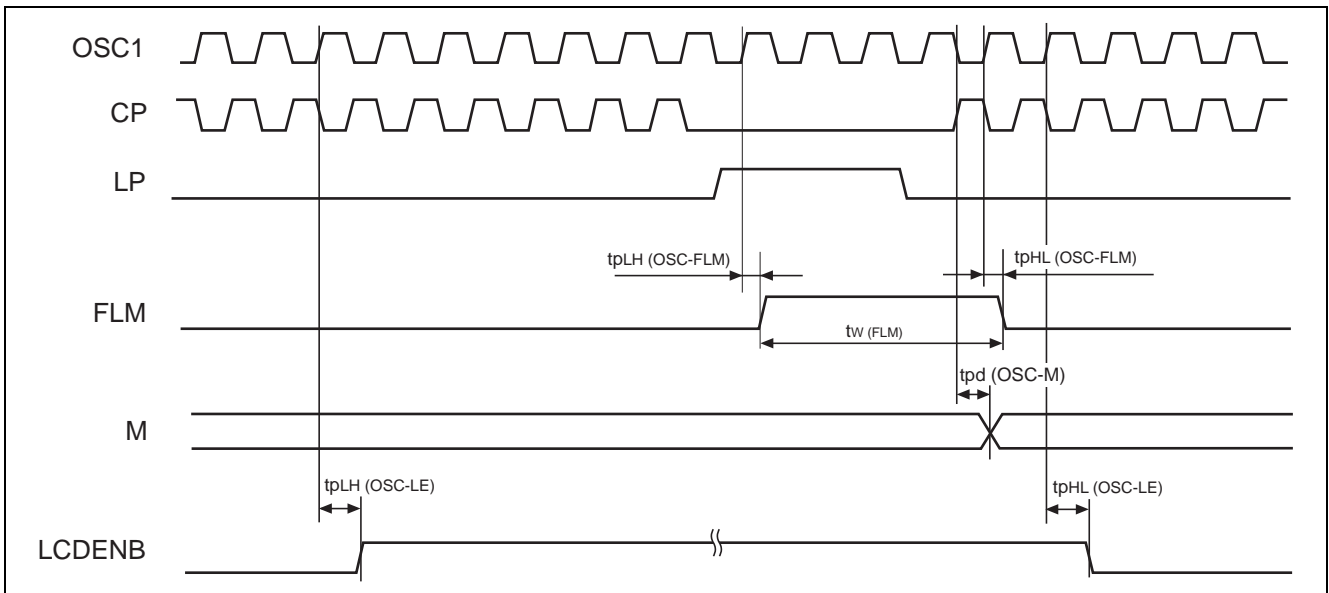

Note: 6. Output signal to LCD side is synchronized with OSC clock for internal operation.
 When division is set to 1/2 to 1/16 by OSCC register, switching characteristics is defined by rising edge of OSC1.

Package Dimensions

JEITA Package Code	RENESAS Code	Previous Code	MASS[Typ.]
P-QFP80-14x20-0.80	PRQP0080GB-A	80P6N-A	1.6g

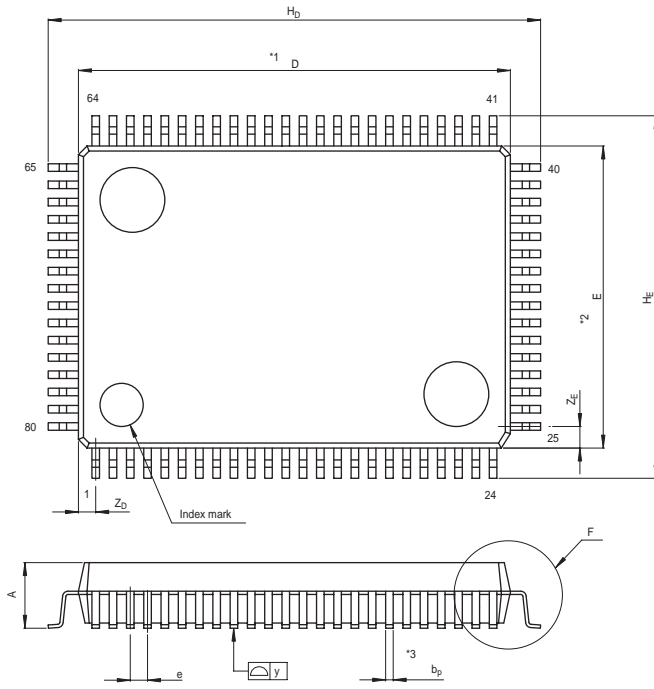

NOTE)
 1. DIMENSIONS **1* AND **2* DO NOT INCLUDE MOLD FLASH.
 2. DIMENSION **3* DOES NOT INCLUDE TRIM OFFSET.

Reference Symbol	Dimension in Millimeters		
	Min	Nom	Max
D	19.8	20.0	20.2
E	13.8	14.0	14.2
A ₂	—	2.8	—
H _D	22.5	22.8	23.1
H _E	16.5	16.8	17.1
A	—	—	3.05
A ₁	0	0.1	0.2
b _p	0.3	0.35	0.45
c	0.13	0.15	0.2
θ	0°	—	10°
e	0.65	0.8	0.95
y	—	—	0.10
Z _D	—	0.8	—
Z _E	—	1.0	—
L	0.4	0.6	0.8

Notes:

1. This document is provided for reference purposes only so that Renesas customers may select the appropriate Renesas products for their use. Renesas neither makes warranties or representations with respect to the accuracy or completeness of the information contained in this document nor grants any license to any intellectual property rights or any other rights of Renesas or any third party with respect to the information in this document.
2. Renesas shall have no liability for damages or infringement of any intellectual property or other rights arising out of the use of any information in this document, including, but not limited to, product data, diagrams, charts, programs, algorithms, and application circuit examples.
3. You should not use the products or the technology described in this document for the purpose of military applications such as the development of weapons of mass destruction or for the purpose of any other military use. When exporting the products or technology described herein, you should follow the applicable export control laws and regulations, and procedures required by such laws and regulations.
4. All information included in this document such as product data, diagrams, charts, programs, algorithms, and application circuit examples, is current as of the date this document is issued. Such information, however, is subject to change without any prior notice. Before purchasing or using any Renesas products listed in this document, please confirm the latest product information with a Renesas sales office. Also, please pay regular and careful attention to additional and different information to be disclosed by Renesas such as that disclosed through our website. (<http://www.renesas.com>)
5. Renesas has used reasonable care in compiling the information included in this document, but Renesas assumes no liability whatsoever for any damages incurred as a result of errors or omissions in the information included in this document.
6. When using or otherwise relying on the information in this document, you should evaluate the information in light of the total system before deciding about the applicability of such information to the intended application. Renesas makes no representations, warranties or guarantees regarding the suitability of its products for any particular application and specifically disclaims any liability arising out of the application and use of the information in this document or Renesas products.
7. With the exception of products specified by Renesas as suitable for automobile applications, Renesas products are not designed, manufactured or tested for applications or otherwise in systems the failure or malfunction of which may cause a direct threat to human life or create a risk of human injury or which require especially high quality and reliability such as safety systems, or equipment or systems for transportation and traffic, healthcare, combustion control, aerospace and aeronautics, nuclear power, or undersea communication transmission. If you are considering the use of our products for such purposes, please contact a Renesas sales office beforehand. Renesas shall have no liability for damages arising out of the uses set forth above.
8. Notwithstanding the preceding paragraph, you should not use Renesas products for the purposes listed below:
 - (1) artificial life support devices or systems
 - (2) surgical implantations
 - (3) healthcare intervention (e.g., excision, administration of medication, etc.)
 - (4) any other purposes that pose a direct threat to human lifeRenesas shall have no liability for damages arising out of the uses set forth in the above and purchasers who elect to use Renesas products in any of the foregoing applications shall indemnify and hold harmless Renesas Technology Corp., its affiliated companies and their officers, directors, and employees against any and all damages arising out of such applications.
9. You should use the products described herein within the range specified by Renesas, especially with respect to the maximum rating, operating supply voltage range, movement power voltage range, heat radiation characteristics, installation and other product characteristics. Renesas shall have no liability for malfunctions or damages arising out of the use of Renesas products beyond such specified ranges.
10. Although Renesas endeavors to improve the quality and reliability of its products, IC products have specific characteristics such as the occurrence of failure at a certain rate and malfunctions under certain use conditions. Please be sure to implement safety measures to guard against the possibility of physical injury, and injury or damage caused by fire in the event of the failure of a Renesas product, such as safety design for hardware and software including but not limited to redundancy, fire control and malfunction prevention, appropriate treatment for aging degradation or any other applicable measures. Among others, since the evaluation of microcomputer software alone is very difficult, please evaluate the safety of the final products or system manufactured by you.
11. In case Renesas products listed in this document are detached from the products to which the Renesas products are attached or affixed, the risk of accident such as swallowing by infants and small children is very high. You should implement safety measures so that Renesas products may not be easily detached from your products. Renesas shall have no liability for damages arising out of such detachment.
12. This document may not be reproduced or duplicated, in any form, in whole or in part, without prior written approval from Renesas.
13. Please contact a Renesas sales office if you have any questions regarding the information contained in this document, Renesas semiconductor products, or if you have any other inquiries.



RENESAS SALES OFFICES

<http://www.renesas.com>

Refer to "<http://www.renesas.com/en/network>" for the latest and detailed information.

Renesas Technology America, Inc.
450 Holger Way, San Jose, CA 95134-1368, U.S.A
Tel: <1> (408) 382-7500, Fax: <1> (408) 382-7501

Renesas Technology Europe Limited
Dukes Meadow, Millboard Road, Bourne End, Buckinghamshire, SL8 5FH, U.K.
Tel: <44> (1628) 585-100, Fax: <44> (1628) 585-900

Renesas Technology (Shanghai) Co., Ltd.
Unit 204, 205, AZIACenter, No.1233 Lujiazui Ring Rd, Pudong District, Shanghai, China 200120
Tel: <86> (21) 5877-1818, Fax: <86> (21) 6887-7858/7898

Renesas Technology Hong Kong Ltd.
7th Floor, North Tower, World Finance Centre, Harbour City, Canton Road, Tsimshatsui, Kowloon, Hong Kong
Tel: <852> 2265-6688, Fax: <852> 2377-3473

Renesas Technology Taiwan Co., Ltd.
10th Floor, No.99, Fushing North Road, Taipei, Taiwan
Tel: <886> (2) 2715-2888, Fax: <886> (2) 3518-3399

Renesas Technology Singapore Pte. Ltd.
1 Harbour Front Avenue, #06-10, Keppel Bay Tower, Singapore 098632
Tel: <65> 6213-0200, Fax: <65> 6278-8001

Renesas Technology Korea Co., Ltd.
Kukje Center Bldg. 18th Fl., 191, 2-ka, Hangang-ro, Yongsan-ku, Seoul 140-702, Korea
Tel: <82> (2) 796-3115, Fax: <82> (2) 796-2145

Renesas Technology Malaysia Sdn. Bhd
Unit 906, Block B, Menara Amcorp, Amcorp Trade Centre, No.18, Jln Persiaran Barat, 46050 Petaling Jaya, Selangor Darul Ehsan, Malaysia
Tel: <603> 7955-9390, Fax: <603> 7955-9510