

**SPECIFICATIONS**

Crimped Ferrule  
Hex Crimp Size 128"  
Contact Pin To Solder

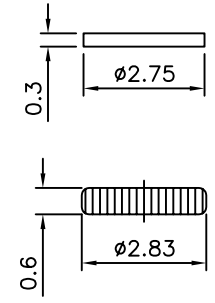
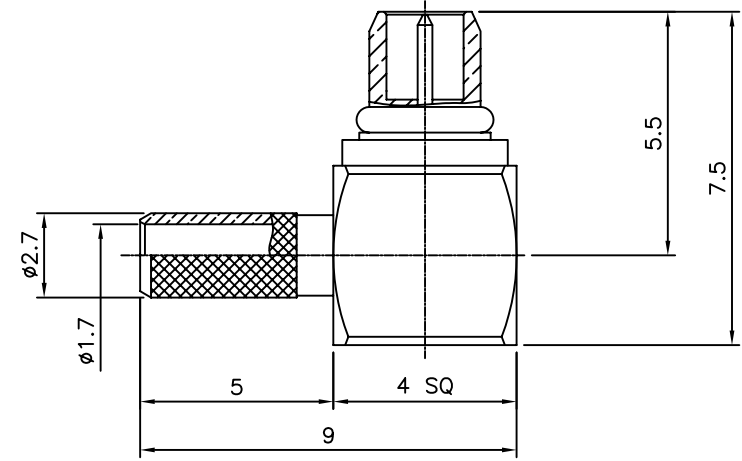
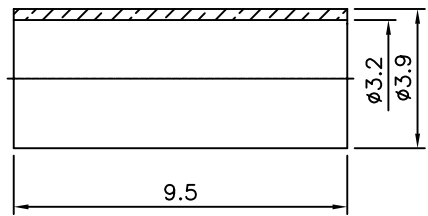
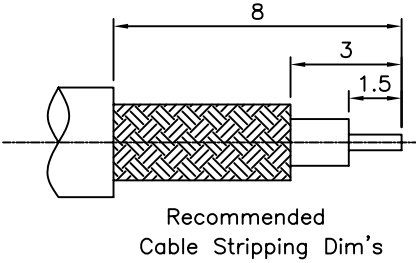

- Notes: Finish (Plating Thickness In Micro-Inches)
- 1.Brass PER QQ-B-626
  - 2.Gold PL 3 Min Over Nickel PL 70 Min Thick Over Copper Strike
  - 3.Gold PL 30 Min Over Nickel PL 70 Min Thick Over Copper Strike
  - 4.Teflon MIL-P-19468
  - 5.Beryllium Copper PER QQ-C-530
  - 6.Brass JIS H 3250 C 2700

Ferrule	Note 6	Note 2
Cover	Note 1	Note 2
Insulator	Note 4	White
C Ring	Note 5	Note 2
Contact Pin	Note 1	Note 3
Insulator	Note 4	White
Body	Note 1	Note 2
Description	Material	Finish

**AUK** A MEMBER OF AUK GROUP  
**太聯事業股份有限公司**  
**AUK CONTRACTORS CO., LTD.**

CATEGORY		APPROVED BY		UNLESS OTHERWISE SPECIFIED TOLERANCES ARE 0.5~6 ±0.2 >6~30 ±0.4 >30~120 ±0.6 >120~315 ±1 >315~1000 ±1.6 ANG ±5°
PART No. MMCX-PCR17475		MEI		
DRAWING No. MMCX-PCR17475		HZF		
		PEGA		
SCALE	NONE	REV.	A0	UNIT mm

NO.	REV.	REVISIONS	CHK	DATE
△ A0		NEW RELEASE	HZF	04/25/2006