

National Semiconductor is now part of  
Texas Instruments.

Search <http://www.ti.com/> for the latest technical  
information and details on our current products and services.

# 10 - 43MHz 14 Bit Color FPD-Link III Serializer and Deserializer with Bidirectional Control Channel

## General Description

The DS90UB901Q/DS90UB902Q chipset offers a FPD-Link III interface with a high-speed forward channel and a bidirectional control channel for data transmission over a single differential pair. The Serializer/Deserializer pair is targeted for direct connections between automotive camera systems and Host Controller/Electronic Control Unit (ECU). The primary transport sends 16 bits of image data over a single high-speed serial stream together with a low latency bidirectional control channel transport that supports I<sup>2</sup>C. Included with the 16-bit payload is a selectable data integrity option for CRC (Cyclic Redundancy Check) to monitor transmission link errors. Using National's embedded clock technology allows transparent full-duplex communication over a single differential pair, carrying asymmetrical bidirectional control information without the dependency of video blanking intervals. This single serial stream simplifies transferring a wide data bus over PCB traces and cable by eliminating the skew problems between parallel data and clock paths. This significantly saves system cost by narrowing data paths that in turn reduce PCB layers, cable width, and connector size and pins.

In addition, the Deserializer inputs provide equalization control to compensate for loss from the media over longer distances. Internal DC balanced encoding/decoding is used to support AC-Coupled interconnects.

A Serializer standby function provides a low power-savings mode with a remote wake up capability for signaling of a remote device.

The Serializer is offered in a 32-pin LLP package, and Deserializer is offered in a 40-pin LLP package.

## Features

- 10 MHz to 43 MHz input PCLK support
- 160 Mbps to 688 Mbps data throughput

- Single differential pair interconnect
- Bidirectional control interface channel with I<sup>2</sup>C support
- Embedded clock with DC Balanced coding to support AC-coupled interconnects
- Capable to drive up to 10 meters shielded twisted-pair
- I<sup>2</sup>C compatible serial interface
- Single hardware device addressing pin
- 16-bit data payload with CRC (Cyclic Redundancy Check) for checking data integrity
- Up to 6 Programmable GPIO's
- LOCK output reporting pin and AT-SPEED BIST diagnosis feature to validate link integrity
- Integrated termination resistors
- 1.8V- or 3.3V-compatible parallel bus interface
- Single power supply at 1.8V
- ISO 10605 ESD and IEC 61000-4-2 ESD compliant
- Automotive grade product: AEC-Q100 Grade 2 qualified
- Temperature range -40°C to +105°C
- No reference clock required on Deserializer
- Programmable Receive Equalization
- EMI/EMC Mitigation
  - DES Programmable Spread Spectrum (SSCG) outputs
  - DES Receiver staggered outputs

## Applications

- Automotive Vision Systems
- Rear View, Side View Camera
- Lane Departure Warning
- Parking Assistance
- Blind Spot View

## Typical Application Diagram

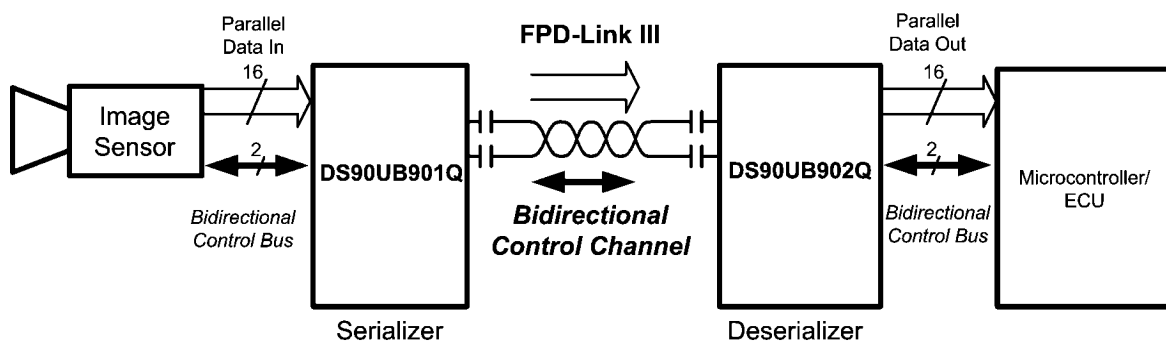

30113527

**FIGURE 1. Typical Application Circuit**

# Block Diagrams

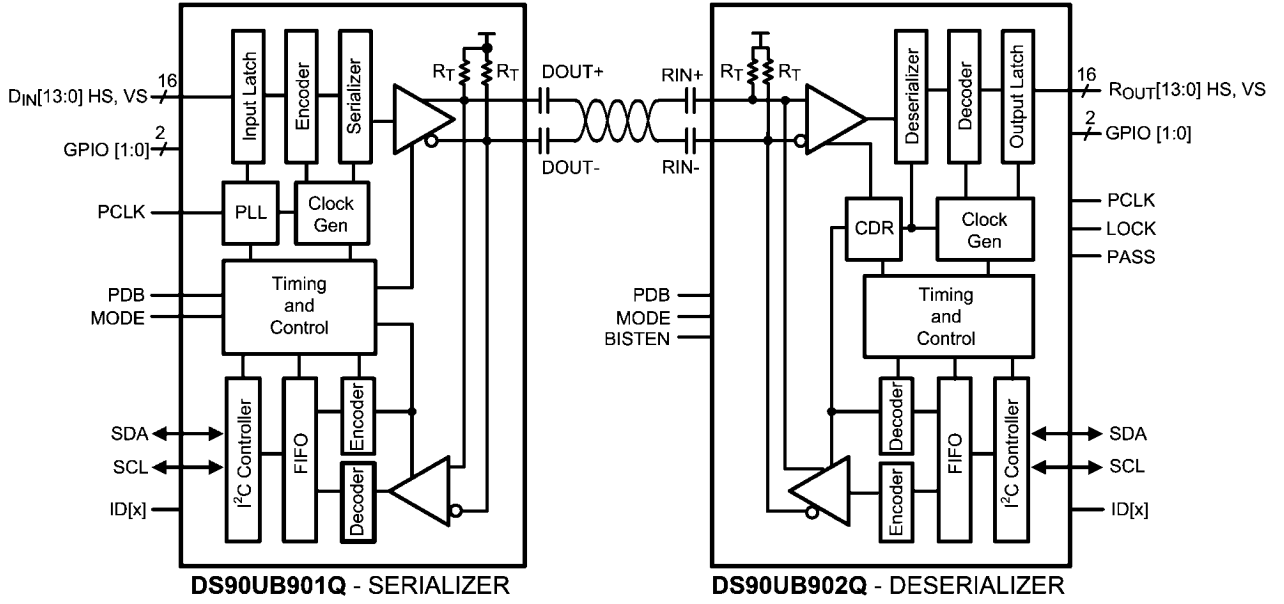

FIGURE 2. Block Diagram

30113528

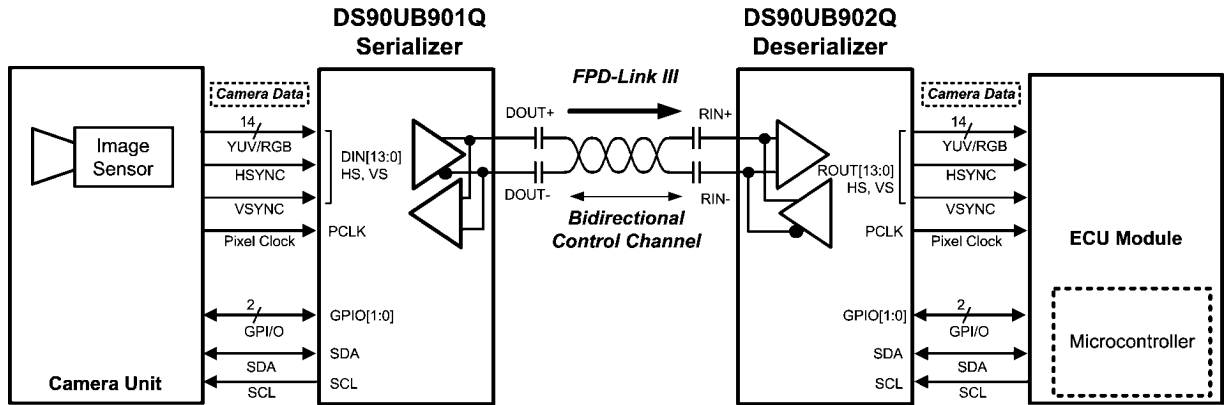

FIGURE 3. Application Block Diagram

30113529

## Ordering Information

NSID	Package Description	Quantity	SPEC	Package ID
DS90UB901QSQE	32-pin LLP, 5.0 X 5.0 X 0.8 mm, 0.5 mm pitch	250	NOPB	SQA32A
DS90UB901QSQ	32-pin LLP, 5.0 X 5.0 X 0.8 mm, 0.5 mm pitch	1000	NOPB	SQA32A
DS90UB901QSQX	32-pin LLP, 5.0 X 5.0 X 0.8 mm, 0.5 mm pitch	4500	NOPB	SQA32A
DS90UB902QSQE	40-pin LLP, 6.0 X 6.0 X 0.8 mm, 0.5 mm pitch	250	NOPB	SQA40A
DS90UB902QSQ	40-pin LLP, 6.0 X 6.0 X 0.8 mm, 0.5 mm pitch	1000	NOPB	SQA40A
DS90UB902QSQX	40-pin LLP, 6.0 X 6.0 X 0.8 mm, 0.5 mm pitch	4500	NOPB	SQA40A

Note: Automotive Grade (Q) product incorporates enhanced manufacturing and support processes for the automotive market, including defect detection methodologies. Reliability qualification is compliant with the requirements and temperature grades defined in the AEC Q100 standard. Automotive Grade products are identified with the letter Q. For more information go to <http://www.national.com/automotive>.

## DS90UB901Q Pin Diagram

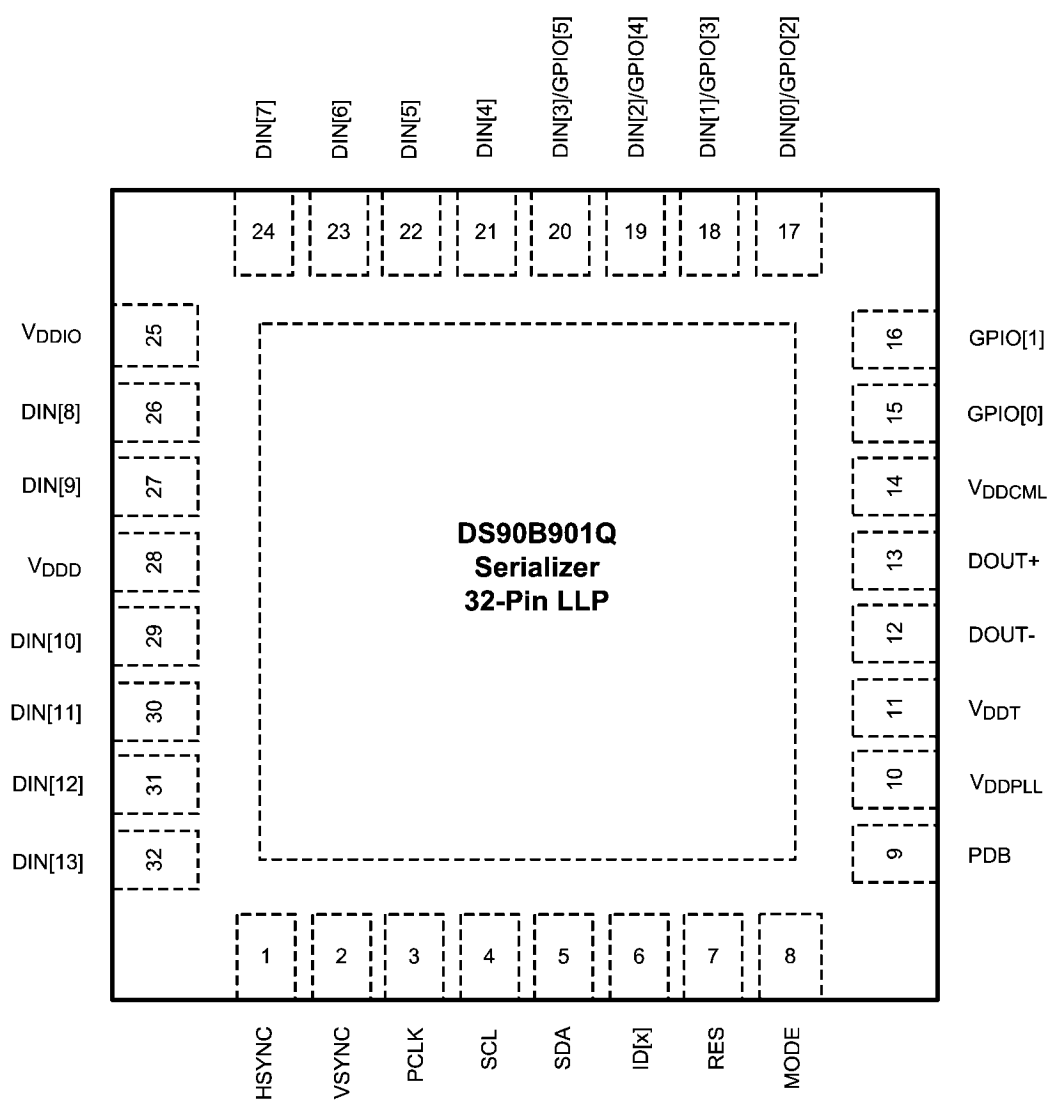

Serializer - DS90UB901Q — Top View

30113519

## DS90UB901Q Serializer Pin Descriptions

Pin Name	Pin No.	I/O, Type	Description
<b>LVC MOS PARALLEL INTERFACE</b>			
DIN[13:0]	32, 31, 30, 29, 27, 26, 24, 23, 22, 21, 20, 19, 18, 17	Inputs, LVC MOS w/ pull down	Parallel data inputs.
HSYNC	1	Inputs, LVC MOS w/ pull down	Horizontal SYNC Input
VSYNC	2	Inputs, LVC MOS w/ pull down	Vertical SYNC Input
PCLK	3	Input, LVC MOS w/ pull down	Pixel Clock Input Pin. Strobe edge set by TRFB control register.
<b>GENERAL PURPOSE INPUT OUTPUT (GPIO)</b>			
DIN[3:0]/GPIO[5:2]	20, 19, 18, 17	Input/Output, LVC MOS	DIN[3:0] general-purpose pins can be individually configured as either inputs or outputs; used to control and respond to various commands.
GPIO[1:0]	16, 15	Input/Output, LVC MOS	General-purpose pins can be individually configured as either inputs or outputs; used to control and respond to various commands.
<b>BIDIRECTIONAL CONTROL BUS - I<sup>2</sup>C COMPATIBLE</b>			
SCL	4	Input/Output, Open Drain	Clock line for the bidirectional control bus communication SCL requires an external pull-up resistor to V <sub>DDIO</sub> .
SDA	5	Input/Output, Open Drain	Data line for the bidirectional control bus communication SDA requires an external pull-up resistor to V <sub>DDIO</sub> .
MODE	8	Input, LVC MOS w/ pull down	I <sup>2</sup> C Mode select MODE = L, Master mode (default); Device generates and drives the SCL clock line. Device is connected to slave peripheral on the bus. (Serializer initially starts up in Standby mode and is enabled through remote wakeup by Deserializer) MODE = H, Slave mode; Device accepts SCL clock input and attached to an I <sup>2</sup> C controller master on the bus. Slave mode does not generate the SCL clock, but uses the clock generated by the Master for the data transfers.
ID[x]	6	Input, analog	Device ID Address Select Resistor to Ground and 10 k $\Omega$ pull-up to 1.8V rail. See <a href="#">Table 3</a>
<b>CONTROL AND CONFIGURATION</b>			
PDB	9	Input, LVC MOS w/ pull down	Power down Mode Input Pin. PDB = H, Serializer is enabled and is ON. PDB = L, Serailizer is in Power Down mode. When the Serializer is in Power Down, the PLL is shutdown, and IDD is minimized. Programmed control register data are NOT retained and reset to default values
RES	7	Input, LVC MOS w/ pull down	Reserved. This pin MUST be tied LOW.
<b>FPD-LINK III INTERFACE</b>			
DOUT+	13	Input/Output, CML	Non-inverting differential output, bidirectional control channel input. The interconnect must be AC Coupled with a 100 nF capacitor.
DOUT-	12	Input/Output, CML	Inverting differential output, bidirectional control channel input. The interconnect must be AC Coupled with a 100 nF capacitor.
<b>POWER AND GROUND</b>			
VDDPLL	10	Power, Analog	PLL Power, 1.8V $\pm$ 5%
VDDT	11	Power, Analog	Tx Analog Power, 1.8V $\pm$ 5%
VDDCML	14	Power, Analog	CML & Bidirectional Channel Driver Power, 1.8V $\pm$ 5%
VDDD	28	Power, Digital	Digital Power, 1.8V $\pm$ 5%

Pin Name	Pin No.	I/O, Type	Description
VDDIO	25	Power, Digital	Power for I/O stage. The single-ended inputs and SDA, SCL are powered from V <sub>DDIO</sub> . V <sub>DDIO</sub> can be connected to a 1.8V ±5% or 3.3V ±10%
VSS	DAP	Ground, DAP	DAP must be grounded. DAP is the large metal contact at the bottom side, located at the center of the LLP package. Connected to the ground plane (GND) with at least 9 vias.

### DS90UB902Q Pin Diagram

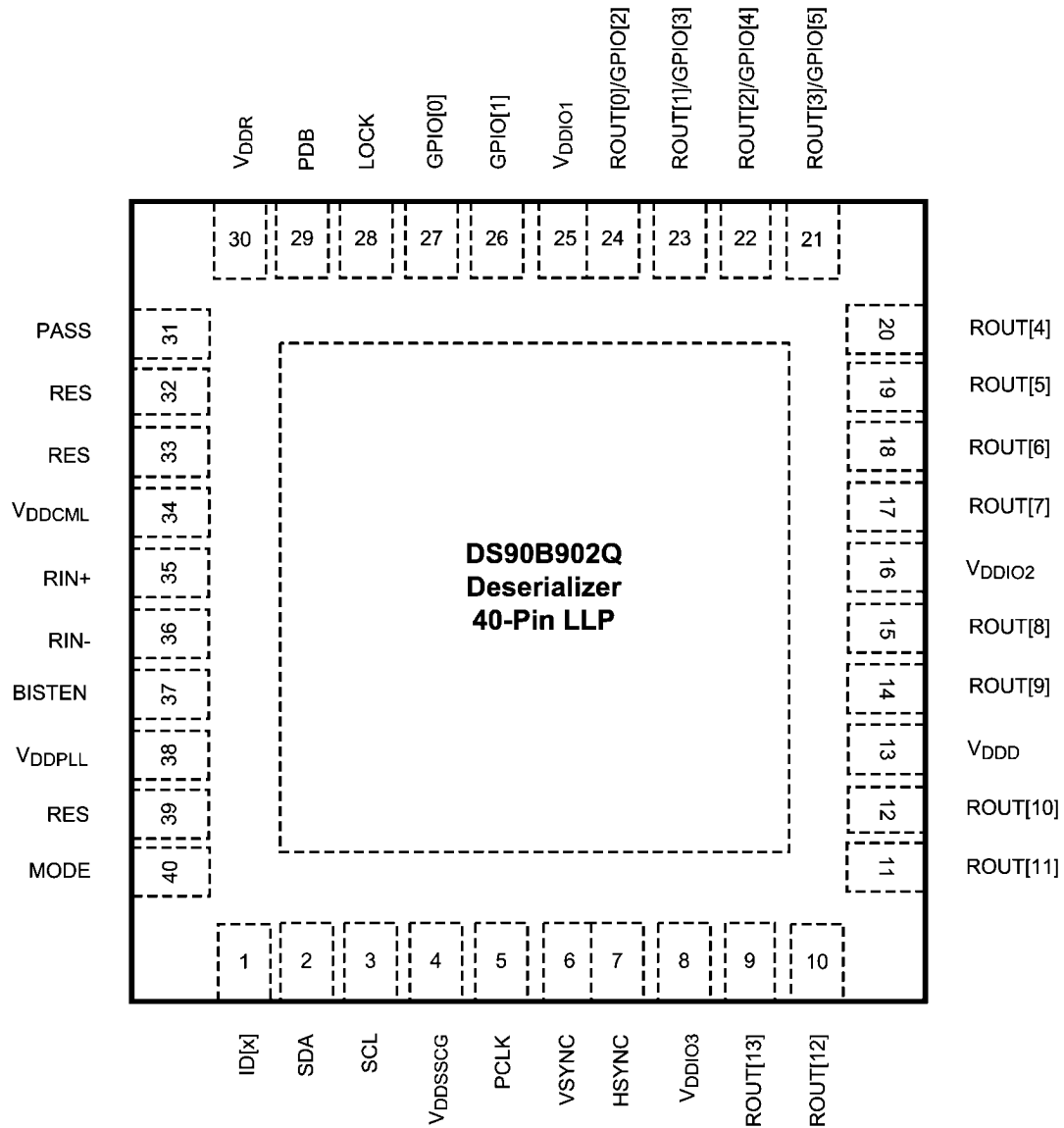

Deserializer - DS90UB902Q — Top View

30113520

## DS90UB902Q Deserializer Pin Descriptions

Pin Name	Pin No.	I/O, Type	Description
<b>LVC MOS PARALLEL INTERFACE</b>			
ROUT[13:0]	9, 10, 11, 12, 14, 15, 17, 18, 19, 20, 21, 22, 23, 24	Outputs, LVC MOS	Parallel data outputs.
HSYNC	7	Output, LVC MOS	Horizontal SYNC Output
VS YNC	6	Output, LVC MOS	Vertical SYNC Output
PCLK	5	Output, LVC MOS	Pixel Clock Output Pin. Strobe edge set by RRFB control register.
<b>GENERAL PURPOSE INPUT OUTPUT (GPIO)</b>			
ROUT[3:0] / GPIO[5:2]	21, 22, 23, 24	Input/Output, LVC MOS	ROUT[3:0] general-purpose pins can be individually configured as either inputs or outputs; used to control and respond to various commands.
GPIO[1:0]	26, 27	Input/Output, LVC MOS	General-purpose pins can be individually configured as either inputs or outputs; used to control and respond to various commands.
<b>BIDIRECTIONAL CONTROL BUS - I<sup>2</sup>C COMPATIBLE</b>			
SCL	3	Input/Output, Open Drain	Clock line for the bidirectional control bus communication SCL requires an external pull-up resistor to V <sub>DDIO</sub> .
SDA	2	Input/Output, Open Drain	Data line for bidirectional control bus communication SDA requires an external pull-up resistor to V <sub>DDIO</sub> .
MODE	40	Input, LVC MOS w/ pull up	I <sup>2</sup> C Mode select MODE = L, Master mode; Device generates and drives the SCL clock line, where required such as Read. Device is connected to slave peripheral on the bus. MODE = H, Slave mode (default); Device accepts SCL clock input and attached to an I <sup>2</sup> C controller master on the bus. Slave mode does not generate the SCL clock, but uses the clock generated by the Master for the data transfers.
ID[x]	1	Input, analog	Device ID Address Select Resistor to Ground and 10 k $\Omega$ pull-up to 1.8V rail. See <a href="#">Table 4</a>
<b>CONTROL AND CONFIGURATION</b>			
PDB	29	Input, LVC MOS w/ pull down	Power down Mode Input Pin. PDB = H, Deserializer is enabled and is ON. PDB = L, Deserializer is in Power Down mode. When the Deserializer is in Power Down. Programmed control register data are NOT retained and reset to default values.
LOCK	28	Output, LVC MOS	LOCK Status Output Pin. LOCK = H, CDR/PLL is Locked, outputs are active LOCK = L, CDR/PLL is unlocked, the LVC MOS Outputs depend on OSS_SEL control register, the CDR/PLL is shutdown and IDD is minimized. May be used as Link Status.
PASS	31	Output, LVC MOS	When BISTEN = L; Normal operation PASS is high to indicate no errors are detected. The PASS pin asserts low to indicate a CRC error was detected on the Link.
RES	32, 33, 39	-	Reserved Pin 39: This pin MUST be tied LOW. Pins 32,33: Route to test point or leave open if unused.
<b>BIST MODE</b>			
BISTEN	37	Input, LVC MOS w/ pull down	BIST Enable Pin. BISTEN = H, BIST Mode is enabled. BISTEN = L, BIST Mode is disabled.

Pin Name	Pin No.	I/O, Type	Description
PASS	31	Output, LVCOMS	PASS Output Pin for BIST mode. PASS = H, ERROR FREE Transmission PASS = L, one or more errors were detected in the received payload. Leave Open if unused. Route to test point (pad) recommended.
<b>FPD-LINK III INTERFACE</b>			
RIN+	35	Input/Output, CML	Noninverting differential input, bidirectional control channel output. The interconnect must be AC Coupled with a 100 nF capacitor.
RIN-	36	Input/Output, CML	Inverting differential input, bidirectional control channel output. The interconnect must be AC Coupled with a 100 nF capacitor.
<b>POWER AND GROUND</b>			
VDDSSCG	4	Power, Digital	SSCG Power, 1.8V $\pm$ 5% Power supply must be connected regardless if SSCG function is in operation.
VDDIO1/2/3	25, 16, 8	Power, Digital	LVTTL I/O Buffer Power, The single-ended outputs and control input are powered from $V_{DDIO}$ . $V_{DDIO}$ can be connected to a 1.8V $\pm$ 5% or 3.3V $\pm$ 10%
VDDD	13	Power, Digital	Digital Core Power, 1.8V $\pm$ 5%
VDDR	30	Power, Analog	Rx Analog Power, 1.8V $\pm$ 5%
VDDCML	34	Power, Analog	Bidirectional Channel Driver Power, 1.8V $\pm$ 5%
VDDPLL	38	Power, Analog	PLL Power, 1.8V $\pm$ 5%
VSS	DAP	Ground, DAP	DAP must be grounded. DAP is the large metal contact at the bottom side, located at the center of the LLP package. Connected to the ground plane (GND) with at least 16 vias.

## Absolute Maximum Ratings *(Note 1)*

If Military/Aerospace specified devices are required, please contact the National Semiconductor Sales Office/Distributors for availability and specifications.

Supply Voltage – $V_{DDn}$ (1.8V)	–0.3V to +2.5V
Supply Voltage – $V_{DDIO}$	–0.3V to +4.0V
LVC MOS Input Voltage I/O Voltage	–0.3V to + ( $V_{DDIO} + 0.3V$ )
CML Driver I/O Voltage ( $V_{DD}$ )	–0.3V to + ( $V_{DD} + 0.3V$ )
CML Receiver I/O Voltage ( $V_{DD}$ )	–0.3V to ( $V_{DD} + 0.3V$ )
Junction Temperature	+150°C
Storage Temperature	–65°C to +150°C
Maximum Package Power Dissipation Capacity Package	$1/\theta_{JA}$ °C/W above +25°
Package Derating: DS90UB901Q 32L LLP	
$\theta_{JA}$ (based on 9 thermal vias)	34.3 °C/W
$\theta_{JC}$ (based on 9 thermal vias)	6.9 °C/W
DS90UB902Q 40L LLP	
$\theta_{JA}$ (based on 16 thermal vias)	28.0 °C/W
$\theta_{JC}$ (based on 16 thermal vias)	4.4 °C/W
ESD Rating (IEC 61000-4-2)	$R_D = 330\Omega$ , $C_S = 150pF$
Air Discharge (DOU <sup>+</sup> , DOU <sup>-</sup> , RIN <sup>+</sup> , RIN <sup>-</sup> )	≥±25 kV
Contact Discharge (DOU <sup>+</sup> , DOU <sup>-</sup> , RIN <sup>+</sup> , RIN <sup>-</sup> )	≥±10 kV
ESD Rating (ISO10605)	$R_D = 330\Omega$ , $C_S = 150/330pF$

ESD Rating (ISO10605)	$R_D = 2K\Omega$ , $C_S = 150/330pF$
Air Discharge (DOU <sup>+</sup> , DOU <sup>-</sup> , RIN <sup>+</sup> , RIN <sup>-</sup> )	≥±15 kV
Contact Discharge (DOU <sup>+</sup> , DOU <sup>-</sup> , RIN <sup>+</sup> , RIN <sup>-</sup> )	≥±10 kV
ESD Rating (HBM)	≥±8 kV

For soldering specifications:

see product folder at [www.national.com](http://www.national.com) and [www.national.com/ms/MS/MS-SOLDERING.pdf](http://www.national.com/ms/MS/MS-SOLDERING.pdf)

## Recommended Operating Conditions

	Min	Nom	Max	Units
Supply Voltage ( $V_{DDn}$ )	1.71	1.8	1.89	V
LVC MOS Supply Voltage ( $V_{DDIO}$ ) OR LVC MOS Supply Voltage ( $V_{DDIO}$ )	1.71	1.8	1.89	V
Supply Noise				
$V_{DDn}$ (1.8V)			25	mVp-p
$V_{DDIO}$ (1.8V)			25	mVp-p
$V_{DDIO}$ (3.3V)			50	mVp-p
Operating Free Air Temperature ( $T_A$ )	-40	+25	+105	°C
PCLK Clock Frequency	10		43	MHz

## Electrical Characteristics *(Note 2, Note 3, Note 4)*

Over recommended operating supply and temperature ranges unless otherwise specified.

Symbol	Parameter	Conditions	Min	Typ	Max	Units
<b>LVC MOS DC SPECIFICATIONS 3.3V I/O (SER INPUTS, DES OUTPUTS, GPIO, CONTROL INPUTS AND OUTPUTS)</b>						
$V_{IH}$	High Level Input Voltage	$V_{IN} = 3.0V$ to 3.6V	2.0		$V_{IN}$	V
$V_{IL}$	Low Level Input Voltage	$V_{IN} = 3.0V$ to 3.6V	GND		0.8	V
$I_{IN}$	Input Current	$V_{IN} = 0V$ or 3.6V $V_{IN} = 3.0V$ to 3.6V	-20	±1	+20	µA
$V_{OH}$	High Level Output Voltage	$V_{DDIO} = 3.0V$ to 3.6V	2.4		$V_{DDIO}$	V
$V_{OL}$	Low Level Output Voltage	$V_{DDIO} = 3.0V$ to 3.6V $I_{OH} = +4$ mA	GND		0.4	V
$I_{OS}$	Output Short Circuit Current	$V_{OUT} = 0V$	Serializer GPIO Outputs		-24	mA
			Deserializer LVC MOS Outputs		-39	
$I_{OZ}$	TRI-STATE® Output Current	PDB = 0V, $V_{OUT} = 0V$ or $V_{DD}$	-20	±1	+20	µA
<b>LVC MOS DC SPECIFICATIONS 1.8V I/O (SER INPUTS, DES OUTPUTS, GPIO, CONTROL INPUTS AND OUTPUTS)</b>						
$V_{IH}$	High Level Input Voltage	$V_{IN} = 1.71V$ to 1.89V	0.65 $V_{IN}$		$V_{IN} + 0.3$	V
$V_{IL}$	Low Level Input Voltage	$V_{IN} = 1.71V$ to 1.89V	GND		0.35 $V_{IN}$	
$I_{IN}$	Input Current	$V_{IN} = 0V$ or 1.89V $V_{IN} = 1.71V$ to 1.89V	-20	±1	+20	µA

Symbol	Parameter	Conditions	Min	Typ	Max	Units	
V <sub>OH</sub>	High Level Output Voltage	V <sub>DDIO</sub> = 1.71V to 1.89V I <sub>OH</sub> = -2 mA	V <sub>DDIO</sub> - 0.45		V <sub>DDIO</sub>	V	
		V <sub>DDIO</sub> = 1.71V to 1.89V I <sub>OH</sub> = -4 mA					
V <sub>OL</sub>	Low Level Output Voltage	V <sub>DDIO</sub> = 1.71V to 1.89V I <sub>OL</sub> = +2 mA	GND		0.45	V	
		V <sub>DDIO</sub> = 1.71V to 1.89V I <sub>OL</sub> = +4 mA					
I <sub>OS</sub>	Output Short Circuit Current	V <sub>OUT</sub> = 0V		Serializer GPIO Outputs	-11	mA	
				Deserializer LVCMOS Outputs	-20		
I <sub>OZ</sub>	TRI-STATE® Output Current	PDB = 0V, V <sub>OUT</sub> = 0V or V <sub>DD</sub>	LVCMOS Outputs	-20	±1	+20	µA
<b>CML DRIVER DC SPECIFICATIONS (DOUT+, DOUT-)</b>							
V <sub>OD</sub>	Output Differential Voltage	R <sub>T</sub> = 100Ω (Figure 7)	268	340	412	mV	
ΔV <sub>OD</sub>	Output Differential Voltage Unbalance	R <sub>L</sub> = 100Ω		1	50	mV	
V <sub>OS</sub>	Output Differential Offset Voltage	R <sub>L</sub> = 100Ω (Figure 7)	V <sub>DD (MIN)</sub> - V <sub>OD (MAX)</sub>	V <sub>DD</sub> - V <sub>OD</sub>	V <sub>DD (MAX)</sub> - V <sub>OD (MIN)</sub>	V	
ΔV <sub>OS</sub>	Offset Voltage Unbalance	R <sub>L</sub> = 100Ω		1	50	mV	
I <sub>OS</sub>	Output Short Circuit Current	DOUT+/- = 0V,		-27		mA	
R <sub>T</sub>	Differential Internal Termination Resistance	Differential across DOUT+ and DOUT-	80	100	120	Ω	
<b>CML RECEIVER DC SPECIFICATIONS (RIN+, RIN-)</b>							
V <sub>TH</sub>	Differential Threshold High Voltage	(Figure 8)			+90	mV	
V <sub>TL</sub>	Differential Threshold Low Voltage		-90				
V <sub>IN</sub>	Differential Input Voltage Range	RIN+ - RIN-	180			mV	
I <sub>IN</sub>	Input Current	V <sub>IN</sub> = V <sub>DD</sub> or 0V, V <sub>DD</sub> = 1.89V	-20	±1	+20	µA	
R <sub>T</sub>	Differential Internal Termination Resistance	Differential across RIN+ and RIN-	80	100	120	Ω	
<b>SER/DES SUPPLY CURRENT *DIGITAL, PLL, AND ANALOG VDD</b>							
I <sub>DDT</sub>	Serializer (Tx) VDDn Supply Current (includes load current)	R <sub>T</sub> = 100Ω WORST CASE pattern (Figure 5)	VDDn = 1.89V PCLK = 43 MHz Default Registers		62	90	mA
		R <sub>T</sub> = 100Ω RANDOM PRBS-7 pattern			55		
I <sub>DDIOT</sub>	Serializer (Tx) VDDIO Supply Current (includes load current)	R <sub>T</sub> = 100Ω WORST CASE pattern (Figure 5)	VDDIO = 1.89V PCLK = 43 MHz Default Registers		2	5	mA
			VDDIO = 3.6V PCLK = 43 MHz Default Registers		7	15	
I <sub>DDTZ</sub>	Serializer (Tx) Supply Current	PDB = 0V; All other LVCMOS Inputs = 0V	VDDn = 1.89V		370	775	µA
I <sub>DDIOTZ</sub>	Power-down		VDDIO = 1.89V		55	125	
			VDDIO = 3.6V		65	135	

Symbol	Parameter	Conditions	Min	Typ	Max	Units	
I <sub>DDR</sub>	Deserializer (Rx) VDDn Supply Current (includes load current)	V <sub>DDn</sub> = 1.89V C <sub>L</sub> = 8 pF WORST CASE Pattern (Figure 5)	PCLK = 43 MHz SSCG[3:0] = ON Default Registers		60	96	mA
		V <sub>DDn</sub> = 1.89V C <sub>L</sub> = 8 pF RANDOM PRBS-7 Pattern	PCLK = 43 MHz Default Registers		53		
I <sub>DDIOR</sub>	Deserializer (Rx) VDDIO Supply Current (includes load current)	V <sub>DDIO</sub> = 1.89V C <sub>L</sub> = 8 pF WORST CASE Pattern (Figure 5)	PCLK = 43 MHz Default Registers		16	25	
		V <sub>DDIO</sub> = 3.6V C <sub>L</sub> = 8 pF WORST CASE Pattern	PCLK = 43 MHz Default Registers		38	64	
I <sub>DDRZ</sub> I <sub>DDIORZ</sub>	Deserializer (Rx) Supply Current Power-down	PDB = 0V; All other LVCMOS Inputs = 0V	V <sub>DDn</sub> = 1.89V		42	400	μA
V <sub>DDIO</sub> = 1.89V				8	40		
V <sub>DDIO</sub> = 3.6V				350	800		

### Recommended Serializer Timing for PCLK (Note 12)

Over recommended operating supply and temperature ranges unless otherwise specified.

Symbol	Parameter	Conditions	Min	Typ	Max	Units
t <sub>TCP</sub>	Transmit Clock Period	10 MHz – 43 MHz	23.3	T	100	ns
t <sub>TCH</sub>	Transmit Clock Input High Time		0.4T	0.5T	0.6T	ns
t <sub>TCIL</sub>	Transmit Clock Input Low Time		0.4T	0.5T	0.6T	ns
t <sub>CLKT</sub>	PCLK Input Transition Time (Figure 9)		0.5		2.4	ns
f <sub>OSC</sub>	Internal oscillator clock source			25		MHz

## Serializer Switching Characteristics

Over recommended operating supply and temperature ranges unless otherwise specified.

Symbol	Parameter	Conditions	Min	Typ	Max	Units
$t_{LHT}$	CML Low-to-High Transition Time	$R_L = 100\Omega$ (Figure 6)		150	330	ps
$t_{HLT}$	CML High-to-Low Transition Time	$R_L = 100\Omega$ (Figure 6)		150	330	ps
$t_{DIS}$	Data Input Setup to PCLK	Serializer Data Inputs (Figure 10)	2.0			ns
$t_{DIH}$	Data Input Hold from PCLK		2.0			ns
$t_{PLD}$	Serializer PLL Lock Time	$R_L = 100\Omega$ (Note 5, Note 11)		1	2	ms
$t_{SD}$	Serializer Delay	$R_T = 100\Omega$ PCLK = 10–43 MHz Register 0x03h b[0] (TRFB = 1) (Figure 12)	6.386T + 5	6.386T + 12	6.386T + 19.7	ns
$t_{JIND}$	Serializer Output Deterministic Jitter	Serializer output intrinsic deterministic jitter. Measured (cycle-cycle) with PRBS-7 test pattern PCLK = 43 MHz (Note 4, Note 13)		0.13		UI
$t_{JINR}$	Serializer Output Random Jitter	Serializer output intrinsic random jitter (cycle-cycle). Alternating-1,0 pattern. PCLK = 43 MHz (Note 4, Note 13)		0.04		UI
$t_{JINT}$	Peak-to-peak Serializer Output Jitter	Serializer output peak-to-peak jitter includes deterministic jitter, random jitter, and jitter transfer from serializer input. Measured (cycle-cycle) with PRBS-7 test pattern. PCLK = 43 MHz (Note 4, Note 13)		0.396		UI
$\lambda_{STXBW}$	Serializer Jitter Transfer Function -3 dB Bandwidth	PCLK = 43 MHz Default Registers (Figure 18) (Note 4)		1.90		MHz
$\delta_{STX}$	Serializer Jitter Transfer Function (Peaking)	PCLK = 43 MHz Default Registers (Figure 18) (Note 4)		0.944		dB
$\delta_{STXf}$	Serializer Jitter Transfer Function (Peaking Frequency)	PCLK = 43 MHz Default Registers (Figure 18) (Note 4)		500		kHz

## Deserializer Switching Characteristics

Over recommended operating supply and temperature ranges unless otherwise specified.

Symbol	Parameter	Conditions	Pin/Freq.	Min	Typ	Max	Units
$t_{RCP}$	Receiver Output Clock Period	$t_{RCP} = t_{TCP}$	PCLK	23.3	T	100	ns
$t_{PDC}$	PCLK Duty Cycle	Default Registers SSCG[3:0] = OFF	PCLK	45	50	55	%
$t_{CLH}$	LVC MOS Low-to-High Transition Time	$V_{DDIO}$ : 1.71V to 1.89V or 3.0V to 3.6V, $C_L = 8$ pF (lumped load)	PCLK	1.3	2.0	2.8	ns
$t_{CHL}$	LVC MOS High-to-Low Transition Time	Default Registers ( <i>Figure 14</i> ) ( <i>Note 10</i> )		1.3	2.0	2.8	
$t_{CLH}$	LVC MOS Low-to-High Transition Time	$V_{DDIO}$ : 1.71V to 1.89V or 3.0V to 3.6V, $C_L = 8$ pF (lumped load)	ROUT[13:0], HSYNC, VSYNC	1.6	2.4	3.3	ns
$t_{CHL}$	LVC MOS High-to-Low Transition Time	Default Registers ( <i>Figure 14</i> ) ( <i>Note 10</i> )		1.6	2.4	3.3	
$t_{ROS}$	ROUT Setup Data to PCLK	$V_{DDIO}$ : 1.71V to 1.89V or 3.0V to 3.6V, $C_L = 8$ pF (lumped load)	ROUT[13:0], HSYNC, VSYNC	0.38T	0.5T		ns
$t_{ROH}$	ROUT Hold Data to PCLK	Default Registers ( <i>Figure 16</i> )		0.38T	0.5T		
$t_{DD}$	Deserializer Delay	Default Registers Register 0x03h b[0] (RRFB = 1) ( <i>Figure 15</i> )	10 MHz–43 MHz	4.571T + 8	4.571T + 12	4.571T + 16	ns
$t_{DDL T}$	Deserializer Data Lock Time	( <i>Figure 13</i> ) ( <i>Note 5</i> )	10 MHz–43 MHz			10	ms
$t_{RJIT}$	Receiver Input Jitter Tolerance	( <i>Figure 17</i> , <i>Figure 19</i> ) ( <i>Note 13</i> , <i>Note 14</i> )	43 MHz		0.53		UI
$t_{RCJ}$	Receiver Clock Jitter	PCLK SSCG[3:0] = OFF ( <i>Note 6</i> , <i>Note 10</i> )	10 MHz		300	550	ps
			43 MHz		120	250	
$t_{DPJ}$	Deserializer Period Jitter	PCLK SSCG[3:0] = OFF ( <i>Note 7</i> , <i>Note 10</i> )	10 MHz		425	600	ps
			43 MHz		320	480	
$t_{DCCJ}$	Deserializer Cycle-to-Cycle Clock Jitter	PCLK SSCG[3:0] = OFF ( <i>Note 8</i> , <i>Note 10</i> )	10 MHz		320	500	ps
			43 MHz		300	500	
fdev	Spread Spectrum Clocking Deviation Frequency	LVC MOS Output Bus SSC[3:0] = ON	20 MHz–43 MHz		$\pm 0.5\%$ to $\pm 2.0\%$		%
fmod	Spread Spectrum Clocking Modulation Frequency	( <i>Figure 20</i> )	20 MHz–43 MHz		9 kHz to 66 kHz		kHz

## Bidirectional Control Bus AC Timing Specifications (SCL, SDA) - I<sup>2</sup>C Compliant (Figure 4)

Over recommended supply and temperature ranges unless otherwise specified.

Symbol	Parameter	Conditions	Min	Typ	Max	Units
<b>RECOMMENDED INPUT TIMING REQUIREMENTS (Note 12)</b>						
f <sub>SCL</sub>	SCL Clock Frequency		>0		100	kHz
t <sub>LOW</sub>	SCL Low Period	f <sub>SCL</sub> = 100 kHz	4.7			μs
t <sub>HIGH</sub>	SCL High Period		4.0			μs
t <sub>HD:STA</sub>	Hold time for a start or a repeated start condition		4.0			μs
t <sub>SU:STA</sub>	Set Up time for a start or a repeated start condition		4.7			μs
t <sub>HD:DAT</sub>	Data Hold Time		0		3.45	μs
t <sub>SU:DAT</sub>	Data Set Up Time		250			ns
t <sub>SU:STO</sub>	Set Up Time for STOP Condition		4.0			μs
t <sub>r</sub>	SCL & SDA Rise Time				1000	ns
t <sub>f</sub>	SCL & SDA Fall Time				300	ns
C <sub>b</sub>	Capacitive load for bus					400
<b>SWITCHING CHARACTERISTICS (Note 11)</b>						
f <sub>SCL</sub>	SCL Clock Frequency	Serializer MODE = 0 – R/W Register 0x05 = 0x40'h		100		kHz
		Deserializer MODE = 0 – READ Register 0x06 b[6:4] = 0x00'h		100		
t <sub>LOW</sub>	SCL Low Period	Serializer MODE = 0 – R/W Register 0x05 = 0x40'h	4.7			μs
		Deserializer MODE = 0 – READ Register 0x06 b[6:4] = 0x00'h				
t <sub>HIGH</sub>	SCL High Period	Serializer MODE = 0 – R/W Register 0x05 = 0x40'h	4.0			μs
		Deserializer MODE = 0 – READ Register 0x06 b[6:4] = 0x00'h				
t <sub>HD:STA</sub>	Hold time for a start or a repeated start condition	Serializer MODE = 0 Register 0x05 = 0x40'h	4.0			μs
t <sub>SU:STA</sub>	Set Up time for a start or a repeated start condition	Serializer MODE = 0 Register 0x05 = 0x40'h	4.7			μs
t <sub>HD:DAT</sub>	Data Hold Time		0		3.45	μs
t <sub>SU:DAT</sub>	Data Set Up Time		250			ns
t <sub>SU:STO</sub>	Set Up Time for STOP Condition	Serializer MODE = 0	4.0			μs
t <sub>f</sub>	SCL & SDA Fall Time				300	ns
t <sub>BUF</sub>	Bus free time between a stop and start condition	Serializer MODE = 0	4.7			μs
t <sub>TIMEOUT</sub>	NACK Time out	Serializer MODE = 1		1		ms
		Deserializer MODE = 1 Register 0x06 b[2:0]=111'b		25		

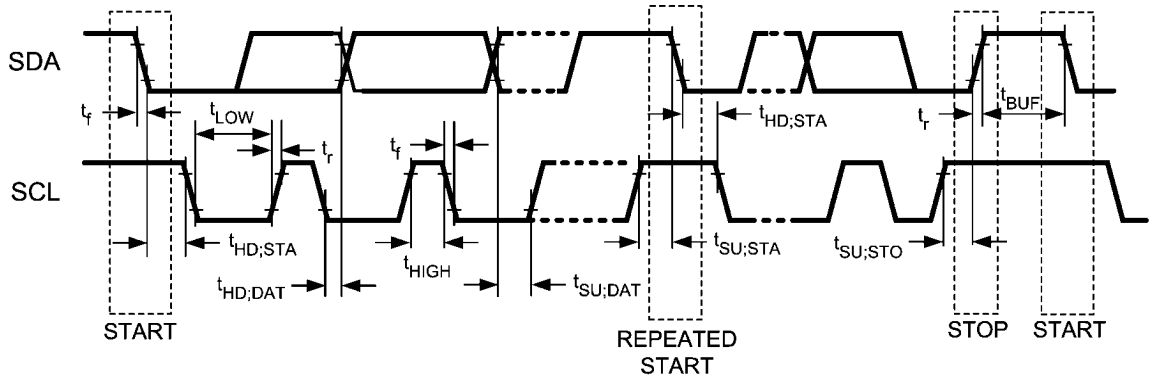

30113536

FIGURE 4. Bidirectional Control Bus Timing

### Bidirectional Control Bus DC Characteristics (SCL, SDA) - I<sup>2</sup>C Compliant

Over recommended supply and temperature ranges unless otherwise specified.

Symbol	Parameter	Conditions	Min	Typ	Max	Units
V <sub>IH</sub>	Input High Level	SDA and SCL	0.7 x V <sub>DDIO</sub>		V <sub>DDIO</sub>	V
V <sub>IL</sub>	Input Low Level Voltage	SDA and SCL	GND		0.3 x V <sub>DDIO</sub>	V
V <sub>HY</sub>	Input Hysteresis	SDA and SCL		>50		mV
I <sub>OZ</sub>	TRI-STATE Output Current	PDB = 0V V <sub>OUT</sub> = 0V or V <sub>DD</sub>	-20	±1	+20	µA
I <sub>IN</sub>	Input Current	SDA or SCL, V <sub>in</sub> = V <sub>DDIO</sub> or GND	-20	±1	+20	µA
C <sub>IN</sub>	Input Pin Capacitance			<5		pF
V <sub>OL</sub>	Low Level Output Voltage	SCL and SDA V <sub>DDIO</sub> = 3.0V I <sub>OL</sub> = 1.5 mA			0.36	V
		SCL and SDA V <sub>DDIO</sub> = 1.71V I <sub>OL</sub> = 1 mA			0.36	V

**Note 1:** "Absolute Maximum Ratings" indicate limits beyond which damage to the device may occur, including inoperability and degradation of device reliability and/or performance. Functional operation of the device and/or non-degradation at the Absolute Maximum Ratings or other conditions beyond those indicated in the Recommended Operating Conditions is not implied. The Recommended Operating Conditions indicate conditions at which the device is functional; the device should not be operated beyond such conditions.

**Note 2:** The Electrical Characteristics tables list guaranteed specifications under the listed Recommended Operating Conditions except as otherwise modified or specified by the Electrical Characteristics Conditions and/or Notes. Typical specifications are estimations only and are not guaranteed.

**Note 3:** Current into device pins is defined as positive. Current out of a device pin is defined as negative. Voltages are referenced to ground except VOD, ΔVOD, VTH and VTL which are differential voltages.

**Note 4:** Typical values represent most likely parametric norms at 1.8V or 3.3V, T<sub>A</sub> = +25°C, and at the Recommended Operation Conditions at the time of product characterization and are not guaranteed.

**Note 5:** t<sub>PLD</sub> and t<sub>DLT</sub> is the time required by the serializer and deserializer to obtain lock when exiting power-down state with an active PCLK

**Note 6:** t<sub>DCJ</sub> is the maximum amount of jitter measured over 30,000 samples based on Time Interval Error (TIE).

**Note 7:** t<sub>DPJ</sub> is the maximum amount the period is allowed to deviate measured over 30,000 samples.

**Note 8:** t<sub>DCCJ</sub> is the maximum amount of jitter between adjacent clock cycles measured over 30,000 samples.

**Note 9:** Supply noise testing was done with minimum capacitors (as shown on Figures 37, 38) on the PCB. A sinusoidal signal is AC coupled to the VDDn (1.8V) supply with amplitude = 25 mVp-p measured at the device VDDn pins. Bit error rate testing of input to the Ser and output of the Des with 10 meter cable shows no error when the noise frequency on the Ser is less than 1 MHz. The Des on the other hand shows no error when the noise frequency is less than 750 kHz.

**Note 10:** Specification is guaranteed by characterization and is not tested in production.

**Note 11:** Specification is guaranteed by design.

**Note 12:** Recommended Input Timing Requirements are input specifications and not tested in production.

**Note 13:** UI – Unit Interval is equivalent to one ideal serialized data bit width. The UI scales with PCLK frequency.

**Note 14:** t<sub>RJIT</sub> max (0.61UI) is limited by instrumentation and actual t<sub>RJIT</sub> of in-band jitter at low frequency (<2 MHz) is greater 1 UI.

# AC Timing Diagrams and Test Circuits

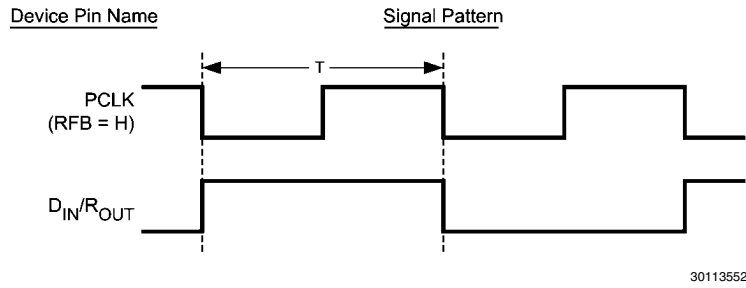

FIGURE 5. "Worst Case" Test Pattern

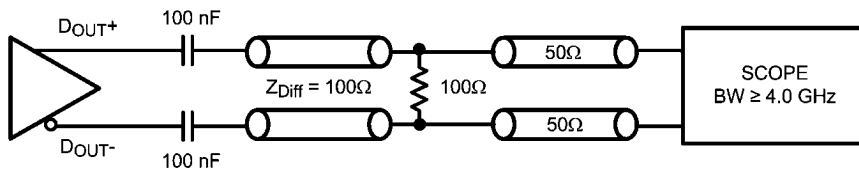
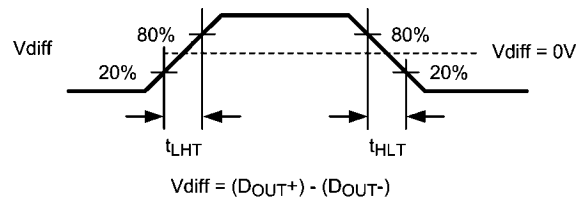
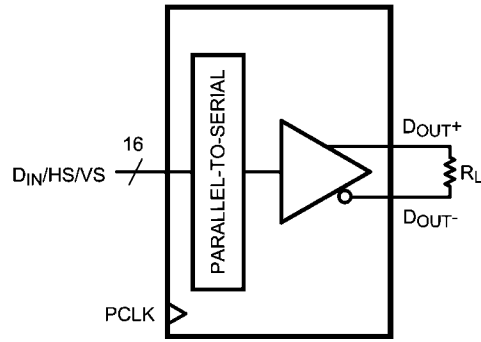
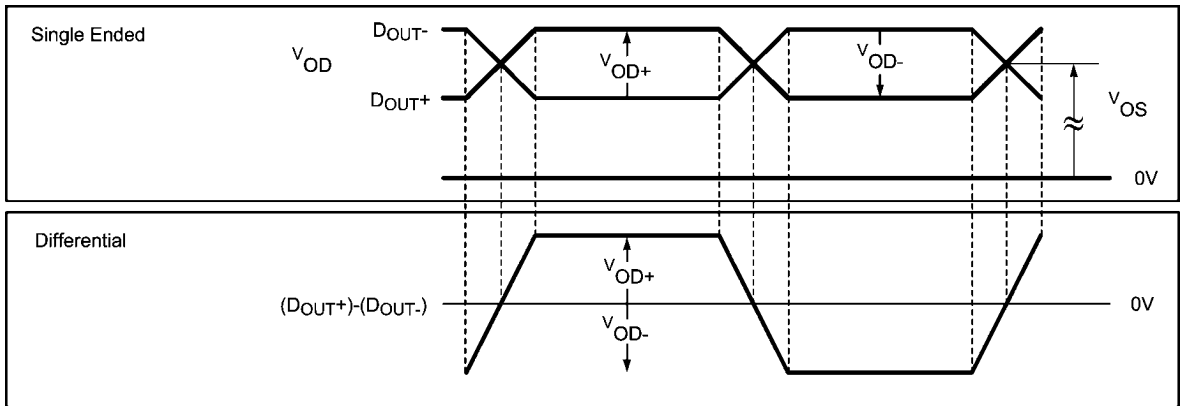

FIGURE 6. Serializer CML Output Load and Transition Times



30113548



30113530

FIGURE 7. Serializer VOD DC Diagram

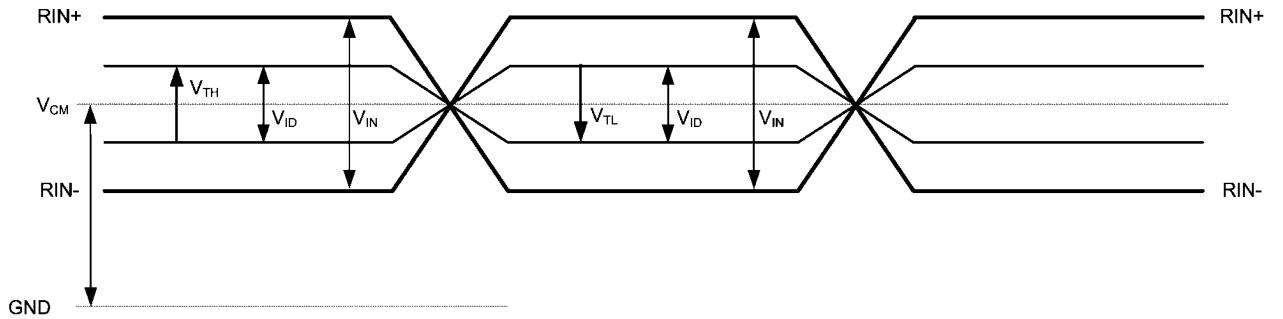

30113534

FIGURE 8. Differential VTH/VTL Definition Diagram

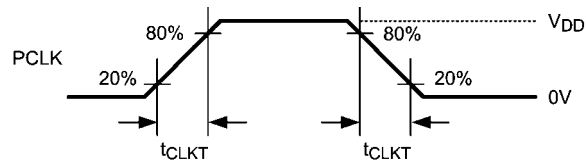

30113516

FIGURE 9. Serializer Input Clock Transition Times

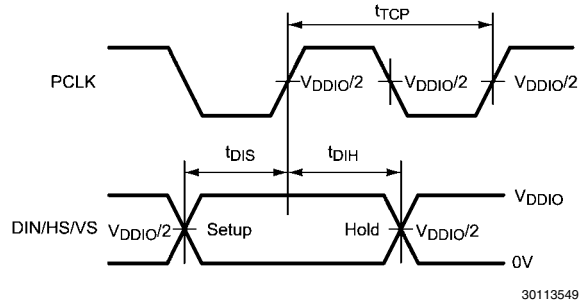

FIGURE 10. Serializer Setup/Hold Times

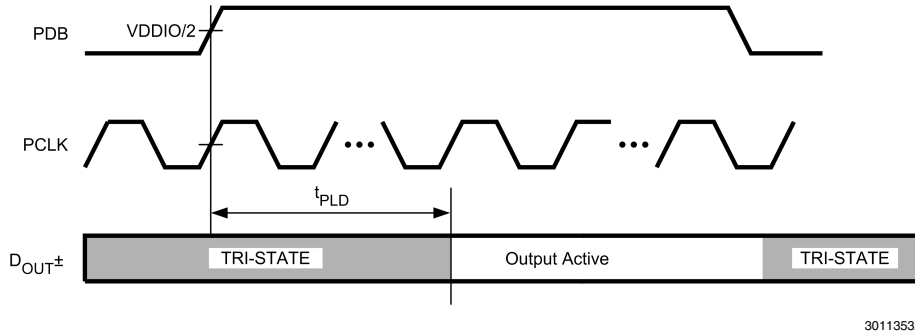

FIGURE 11. Serializer Data Lock Time

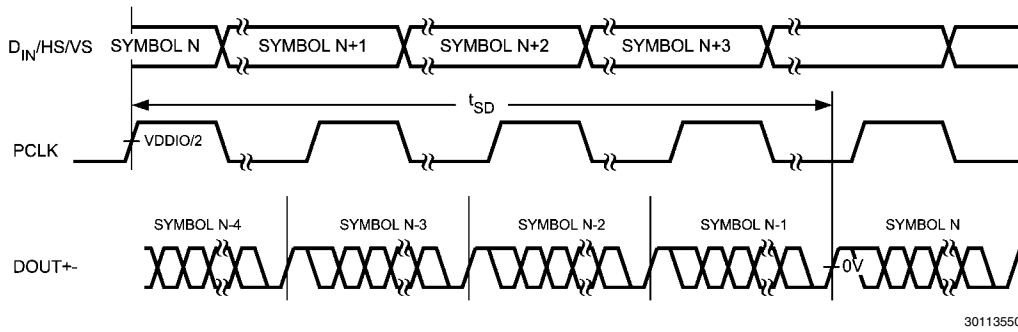

FIGURE 12. Serializer Delay

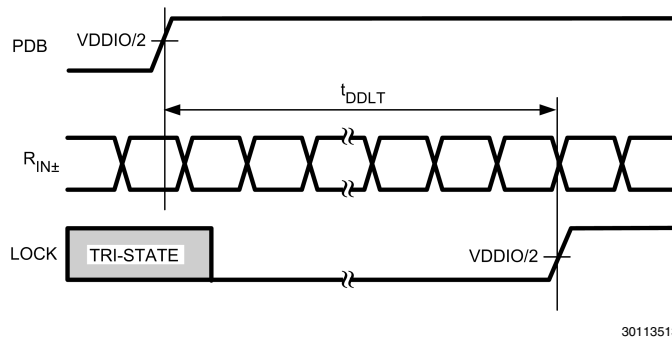
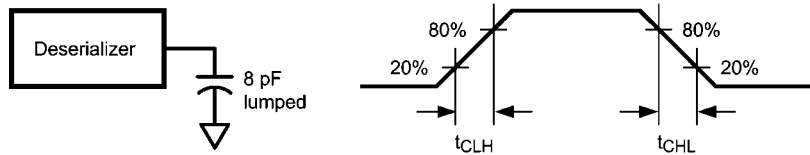
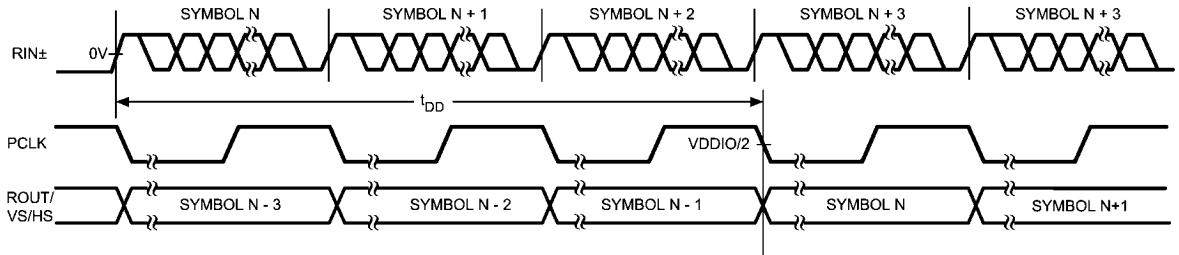

FIGURE 13. Deserializer Data Lock Time



30113514

FIGURE 14. Deserializer LVC MOS Output Load and Transition Times



30113511

FIGURE 15. Deserializer Delay

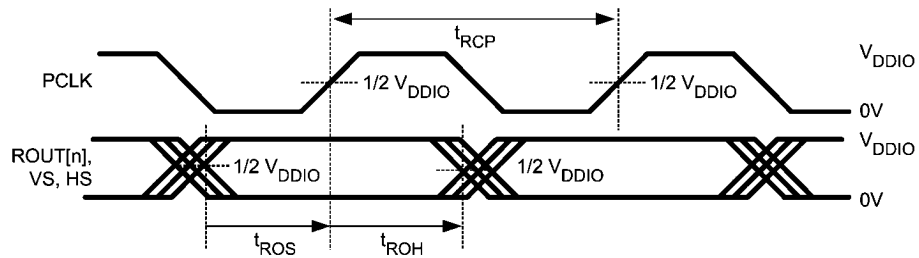

30113531

FIGURE 16. Deserializer Output Setup/Hold Times

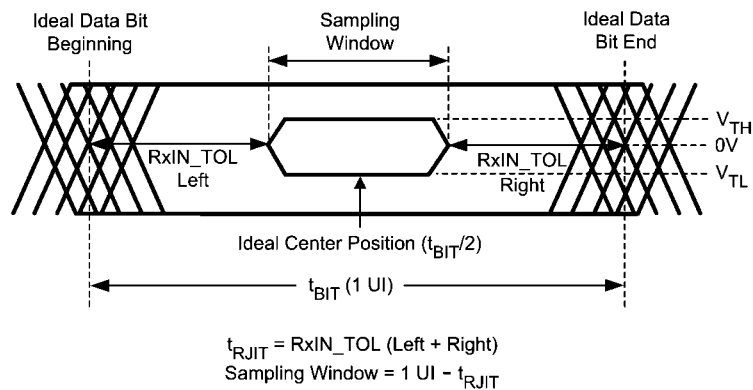

30113558

FIGURE 17. Receiver Input Jitter Tolerance

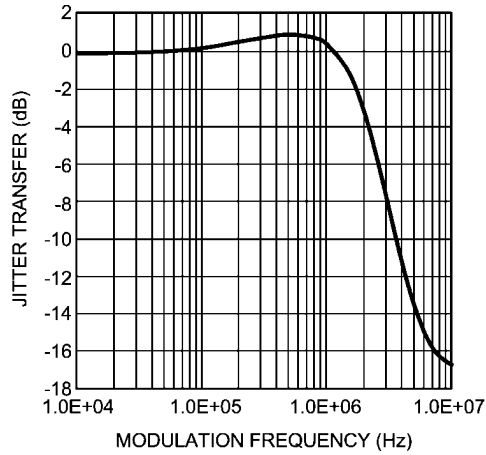

30113562

FIGURE 18. Typical Serializer Jitter Transfer Function Curve at 43 MHz

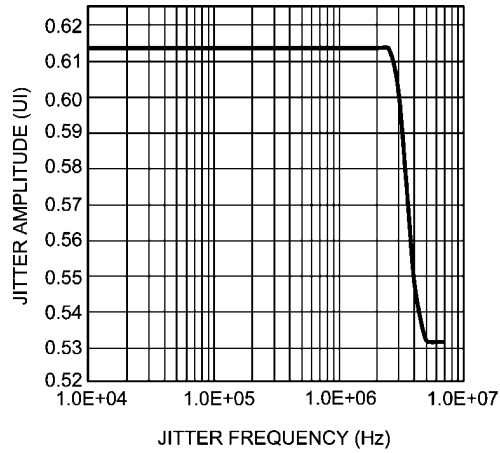

30113559

FIGURE 19. Typical Deserializer Input Jitter Tolerance Curve at 43 MHz

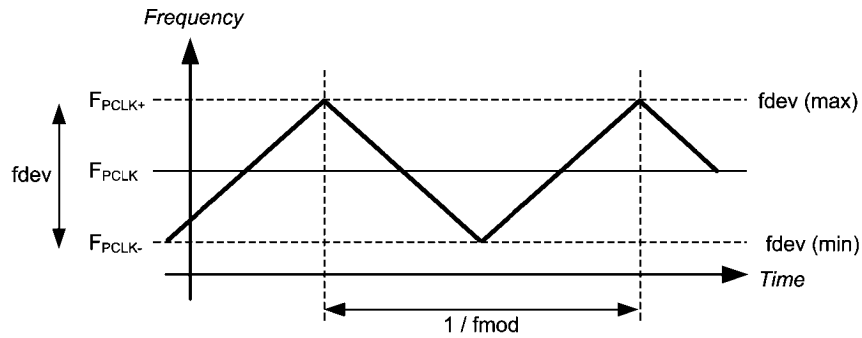

30113535

FIGURE 20. Spread Spectrum Clock Output Profile

**TABLE 1. DS90UB901Q Control Registers**

Addr (Hex)	Name	Bits	Field	R/W	Default	Description
0	I <sup>2</sup> C Device ID	7:1	DEVICE ID	RW	0xB0'h	7-bit address of Serializer; 0x58'h (1011_000X'b) default
		0	SER ID SEL			0: Device ID is from ID[x] 1: Register I <sup>2</sup> C Device ID overrides ID[x]
1	Reset	7:3	RESERVED		0x00'h	Reserved
		2	STANDBY	RW	0	Standby mode control. Retains control register data. Supported only when MODE = 0 0: Enabled. Low-current Standby mode with wake-up capability. Suspends all clocks and functions. 1: Disabled. Standby and wake-up disabled
		1	DIGITAL RESET0	RW	0 self clear	1: Resets the device to default register values. Does not affect device I <sup>2</sup> C Bus or Device ID
		0	DIGITAL RESET1	RW	0 self clear	1: Digital Reset, retains all register values
2	Reserved	7:0	RESERVED		0x20'h	Reserved
3	CRC Fault Tolerant Transmission	7	RX CRC CHECKER ENABLE	RW	1	Back Channel CRC Enable 0: Disable 1: Enable For proper CRC operation, on Deserailizer 0x03h b[6] control register must be Enabled.
		6	TX CRC GEN ENABLE	RW	1	Foward Channel CRC Enable 0: Disable 1: Enable For proper CRC operation, on Deserailizer 0x03h b[7] control register must be Enabled.
	VDDIO Control	5	VDDIO CONTROL	RW	1	Auto V <sub>DDIO</sub> detect Allows manual setting of VDDIO by register. 0: Disable 1: Enable (auto detect mode)
	VDDIO Mode	4	VDDIO MODE	RW	1	VDDIO voltage set Only used when VDDIOCONTROL = 0 0: 1.8V 1: 3.3V
	I <sup>2</sup> C Pass-Through	3	I <sup>2</sup> C PASS-THROUGH	RW	1	I <sup>2</sup> C Pass-Through 0: Disabled 1: Enabled
	RESERVED	2	RESERVED		0	Reserved
	PCLK_AUTO	1	PCLK_AUTO	RW	1	Switch over to internal 25 MHz Oscillator clock in the absence of PCLK 0: Disable 1: Enable
	TRFB	0	TRFB	RW	1	Pixel Clock Edge Select: 0: Parallel Interface Data is strobed on the Falling Clock Edge. 1: Parallel Interface Data is strobed on the Rising Clock Edge.
4	CRC Transmission	7:6	RESERVED		10'b	Reserved
		5	CRC RESET	RW	0	1: CRC Reset. Clears CRC Error counter.
		4:0	RESERVED		00000'b	Reserved

Addr (Hex)	Name	Bits	Field	R/W	Default	Description
5	I <sup>2</sup> C Bus Rate	7:0	I <sup>2</sup> C BUS RATE	RW	0x40'h	I <sup>2</sup> C SCL frequency is determined by the following: f <sub>SCL</sub> = 6.25 MHz / Register value (in decimal) 0x40'h = ~100 kHz SCL (default) Note: Register values <0x32'h are NOT supported.
6	DES ID	7:1	DES DEV ID	RW	0xC0'h	Deserializer Device ID = 0x60'h (1100_000X'b) default
		0	RESERVED			Reserved
7	Slave ID	7:1	SLAVE DEV ID	RW	0x00'h	Slave Device ID. Sets remote slave I <sup>2</sup> C address.
		0	RESERVED			Reserved
8	Reserved	7:0	RESERVED		0x00'h	Reserved
9	Reserved	7:0	RESERVED		0x01'h	Reserved
A	CRC Errors	7:0	CRC ERROR B0	R	0x00'h	Number of CRC errors - 8 LSBs
B	CRC Errors	7:0	CRC ERROR B1	R	0x00'h	Number of CRC errors - 8 MSBs
C	Reserved	7:3	RESERVED		0x00'h	Reserved
	PCLK Detect	2	PCLK DETECT	R	0	1: Valid PCLK detected 0: Valid PCLK not detected
	CRC Check	1	DES ERROR	R	0	1: CRC error during communication with Deserializer
	Cable Link Detect Status	0	LINK DETECT	R	0	0: Cable link not detected 1: Cable link detected
D	GPIO[0] Config	7:4	RESERVED		0001'b	Reserved
		3:2	RESERVED		00'b	Reserved
		1	GPIO0 DIR	RW	0	0: Output 1: Input
		0	GPIO0 EN	RW	1	0: TRI-STATE 1: Enabled
E	GPIO[1] Config	7:4	RESERVED		0000'b	Reserved
		3:2	RESERVED		00'b	Reserved
		1	GPIO1 DIR	RW	0	0: Output 1: Input
		0	GPIO1 EN	RW	1	0: TRI-STATE 1: Enabled
F	GPIO[2] Config	7:4	RESERVED		0000'b	Reserved
		3:2	RESERVED		00'b	Reserved
		1	GPIO2 DIR	RW	1	0: Output 1: Input
		0	GPIO2 EN	RW	1	0: TRI-STATE 1: Enabled
10	GPIO[3] Config	7:4	RESERVED		0000'b	Reserved
		3:2	RESERVED		00'b	Reserved
		1	GPIO3 DIR	RW	1	0: Output 1: Input
		0	GPIO3 EN	RW	1	0: TRI-STATE 1: Enabled
11	GPIO[4] Config	7:4	RESERVED		0000'b	Reserved
		3:2	RESERVED		00'b	Reserved
		1	GPIO4 DIR	RW	1	0: Output 1: Input
		0	GPIO4 EN	RW	1	0: TRI-STATE 1: Enabled

Addr (Hex)	Name	Bits	Field	R/W	Default	Description
12	GPIO[5] Config	7:4	RESERVED		0000'b	Reserved
		3:2	RESERVED		00'b	Reserved
		1	GPIO5 DIR	RW	1	0: Output 1: Input
		0	GPIO5 EN	RW	1	0: TRI-STATE 1: Enabled
13	General Purpose Control Reg	7:0	GPCR[7] GPCR[6] GPCR[5] GPCR[4] GPCR[3] GPCR[2] GPCR[1] GPCR[0]	RW	0x00'h	0: LOW 1: HIGH

**TABLE 2. DS90UB902Q Control Registers**

Addr (Hex)	Name	Bits	Field	R/W	Default	Description
0	I <sup>2</sup> C Device ID	7:1	DEVICE ID	RW	0xC0'h	7-bit address of Deserializer; 0x60h (1100_000X) default
		0	DES ID SEL			0: Device ID is from ID[x] 1: Register I <sup>2</sup> C Device ID overrides ID[x]
1	Reset	7:3	RESERVED		0x00'h	Reserved
		2	REM_WAKEUP	RW	0	Remote Wake-up Select 1: Enable Generate remote wakeup signal automatically wake-up the Serializer in Standby mode 0: Disable Puts the Serializer (MODE = 0) in Standby mode when Deserializer MODE = 1
		1	DIGITALRESET0	RW	0 self clear	1: Resets the device to default register values. Does not affect device I <sup>2</sup> C Bus or Device ID
		0	DIGITALRESET1	RW	0 self clear	1: Digital Reset, retains all register values
2	RESERVED	7:6	RESERVED		00'b	Reserved
	Auto Clock	5	AUTO_CLOCK	RW	0	1: Output PCLK or Internal 25 MHz Oscillator clock 0: Only PCLK when valid PCLK present
	OSS Select	4	OSS_SEL	RW	0	Output Sleep State Select 0: Outputs = TRI-STATE, when LOCK = L 1: Outputs = LOW, when LOCK = L
	SSCG	3:0	SSCG		0000'b	SSCG Select 0000: Normal Operation, SSCG OFF (default) 0001: fmod (kHz) PCLK/2168, fdev ±0.50% 0010: fmod (kHz) PCLK/2168, fdev ±1.00% 0011: fmod (kHz) PCLK/2168, fdev ±1.50% 0100: fmod (kHz) PCLK/2168, fdev ±2.00% 0101: fmod (kHz) PCLK/1300, fdev ±0.50% 0110: fmod (kHz) PCLK/1300, fdev ±1.00% 0111: fmod (kHz) PCLK/1300, fdev ±1.50% 1000: fmod (kHz) PCLK/1300, fdev ±2.00% 1001: fmod (kHz) PCLK/868, fdev ±0.50% 1010: fmod (kHz) PCLK/868, fdev ±1.00% 1011: fmod (kHz) PCLK/868, fdev ±1.50% 1100: fmod (kHz) PCLK/868, fdev ±2.00% 1101: fmod (kHz) PCLK/650, fdev ±0.50% 1110: fmod (kHz) PCLK/650, fdev ±1.00% 1111: fmod (kHz) PCLK/650, fdev ±1.50%

Addr (Hex)	Name	Bits	Field	R/W	Default	Description
3	CRC Fault Tolerant Transmission	7	TX CRC CHECKER ENABLE	RW	1	Back Channel CRC Enable 0: Disable 1: Enable For proper CRC operation, on Serailizer 0x03h b[6] control register must be Enabled.
		6	RX CRC GEN ENABLE	RW	1	Foward Channel CRC Enable 0: Disable 1: Enable For proper CRC operation, on Serailizer 0x03h b[7] control register must be Enabled.
	VDDIO Control	5	VDDIO CONTROL	RW	1	Auto voltage control 0: Disable 1: Enable (auto detect mode)
	VDDIO Mode	4	VDDIO MODE	RW	0	VDDIO voltage set 0: 1.8V 1: 3.3V
	I <sup>2</sup> C Pass-Through	3	I <sup>2</sup> C PASS-THROUGH	RW	1	I <sup>2</sup> C Pass-Through Mode 0: Disabled 1: Enabled
	Auto ACK	2	AUTO ACK	RW	0	0: Disable 1: Enable
	CRC Reset	1	CRC RESET	RW	0	1: CRC reset
	RRFB	0	RRFB	RW	1	Pixel Clock Edge Select 0: Parallel Interface Data is strobed on the Falling Clock Edge 1: Parallel Interface Data is strobed on the Rising Clock Edge.
4	EQ Control	7:0	EQ	RW	0x00'h	EQ Gain 00'h = ~0.0 dB 01'h = ~4.5 dB 03'h = ~6.5 dB 07'h = ~7.5 dB 0F'h = ~8.0 dB 1F'h = ~11.0 dB 3F'h = ~12.5 dB FF'h = ~14.0 dB
5	RESERVED	7:0	RESERVED		0x00'h	Reserved

Addr (Hex)	Name	Bits	Field	R/W	Default	Description
6	RESERVED	7	RESERVED		0	Reserved
	SCL Prescale	6:4	SCL_PRESCALE	RW	000'b	Prescales the SCL clock line when reading data byte from a slave device (MODE = 0) 000 : ~100 kHz SCL (default) 001 : ~125 kHz SCL 101 : ~11 kHz SCL 110 : ~33 kHz SCL 111 : ~50 kHz SCL Other values are NOT supported.
	Remote NACK	3	REM_NACK_TIMER	RW	1	Remote NACK Timer Enable In slave mode (MODE = 1) if bit is set the I <sup>2</sup> C core will automatically timeout when no acknowledge condition was detected. 1: Enable 0: Disable
	Remote NACK	2:0	NACK_TIMEOUT	RW	111'b	Remote NACK Timeout. 000: 2.0 ms 001: 5.2 ms 010: 8.6 ms 011: 11.8 ms 100: 14.4 ms 101: 18.4 ms 110: 21.6 ms 111: 25.0 ms
7	SER ID	7:1	SER DEV ID	RW	0xB0'h	Serializer Device ID = 0x58'h (1011_000X'b) default
		0	RESERVED			Reserved
8	ID[0] Index	7:1	ID[0] INDEX	RW	0x00'h	Target slave Device ID slv_id0 [7:1]
		0	RESERVED			Reserved
9	ID[1] Index	7:1	ID[1] INDEX	RW	0x00'h	Target slave Device ID slv_id1 [7:1]
		0	RESERVED			Reserved
A	ID[2] Index	7:1	ID[2] INDEX	RW	0x00'h	Target slave Device ID slv_id2 [7:1]
		0	RESERVED			Reserved
B	ID[3] Index	7:1	ID[3] INDEX	RW	0x00'h	Target slave Device ID slv_id3 [7:1]
		0	RESERVED			Reserved
C	ID[4] Index	7:1	ID[4] INDEX	RW	0x00'h	Target slave Device ID slv_id4 [7:1]
		0	RESERVED			Reserved
D	ID[5] Index	7:1	ID[5] INDEX	RW	0x00'h	Target slave Device ID slv_id5 [7:1]
		0	RESERVED			Reserved
E	ID[6] Index	7:1	ID[6] INDEX	RW	0x00'h	Target slave Device ID slv_id6 [7:1]
		0	RESERVED			Reserved
F	ID[7] Index	7:1	ID[7] INDEX	RW	0x00'h	Target slave Device ID slv_id7 [7:1]
		0	RESERVED			Reserved
10	ID[0] Match	7:1	ID[0] MATCH	RW	0x00'h	Alias to match Device ID slv_id0 [7:1]
		0	RESERVED			Reserved
11	ID[1] Match	7:1	ID[1] MATCH	RW	0x00'h	Alias to match Device ID slv_id1 [7:1]
		0	RESERVED			Reserved
12	ID[2] Match	7:1	ID[2] MATCH	RW	0x00'h	Alias to match Device ID slv_id2 [7:1]
		0	RESERVED			Reserved
13	ID[3] Match	7:1	ID[3] MATCH	RW	0x00'h	Alias to match Device ID slv_id3 [7:1]
		0	RESERVED			Reserved

Addr (Hex)	Name	Bits	Field	R/W	Default	Description
14	ID[4] Match	7:1	ID[4] MATCH	RW	0x00'h	Alias to match Device ID slv_id4 [7:1]
		0	RESERVED			Reserved
15	ID[5] Match	7:1	ID[5] MATCH	RW	0x00'h	Alias to match Device ID slv_id5 [7:1]
		0	RESERVED			Reserved
16	ID[6] Match	7:1	ID[6] MATCH	RW	0x00'h	Alias to match Device ID slv_id6 [7:1]
		0	RESERVED			Reserved
17	ID[7] Match	7:1	ID[7] MATCH	RW	0x00'h	Alias to match Device ID slv_id [7:1]
		0	RESERVED			Reserved
18	RESERVED	7:0	RESERVED		0x00'h	Reserved
19	RESERVED	7:0	RESERVED		0x01'h	Reserved
1A	CRC Errors	7:0	CRC ERROR B0	R	0x00'h	Number of CRC errors 8 LSBs
1B	CRC Errors	7:0	CRC ERROR B1	R	0x00'h	Number of CRC errors 8 MSBs
1C	RESERVED	7:3	RESERVED		0x00'h	Reserved
	CRC Check	2	SER ERROR	R	0	CRC error during communication with Serializer on Forward Channel
	Signal Detect Status	1		R	0	0: Active signal not detected 1: Active signal detected
	LOCK Pin Status	0		R	0	0: CDR/PLL Unlocked 1: CDR/PLL Locked
1D	GPIO[0] Config	7:3	RESERVED		00010'b	Reserved
		2	GPIO0 SET	RW	1	1: Configured as GPIO 0: Configured as ROUT data (OSS_SEL controlled)
		1	GPIO0 DIR		1	0: Output 1: Input
		0	GPIO0 EN	RW	1	0: TRI-STATE 1: Enabled
1E	GPIO[1] Config	7:3	RESERVED		0x00'h	Reserved
		2	GPIO1 SET	RW	1	1: Configured as GPIO 0: Configured as ROUT data (OSS_SEL controlled)
		1	GPIO1 DIR	RW	1	0: Output 1: Input
		0	GPIO1 EN	RW	1	0: TRI-STATE 1: Enabled
1F	GPIO[2] Config	7:3	RESERVED		0x00'h	Reserved
		2	GPIO2 SET	RW	0	1: Configured as GPIO 0: Configured as ROUT0 data (OSS_SEL controlled)
		1	GPIO2 DIR	RW	0	0: Output 1: Input
		0	GPIO2 EN	RW	1	0: TRI-STATE 1: Enabled
20	GPIO[3] Config	7:3	RESERVED		0x00'h	Reserved
		2	GPIO3 SET	RW	0	1: Configured as GPIO 0: Configured as ROUT1 data (OSS_SEL controlled)
		1	GPIO3 DIR	RW	0	0: Output 1: Input
		0	GPIO3 EN	RW	1	0: TRI-STATE 1: Enabled

Addr (Hex)	Name	Bits	Field	R/W	Default	Description
21	GPIO[4] Config	7:3	RESERVED		0x00'h	Reserved
		2	GPIO4 SET	RW	0	1: Configured as GPIO 0: Configured as ROUT2 data (OSS_SEL controlled)
		1	GPIO4 DIR	RW	0	0: Output 1: Input
		0	GPIO4 EN	RW	1	0: TRI-STATE 1: Enabled
22	GPIO[5] Config	7:3	RESERVED		0x00'h	Reserved
		2	GPIO5 SET	RW	0	1: Configured as GPIO 0: Configured as ROUT3 data (OSS_SEL controlled)
		1	GPIO5 DIR	RW	0	0: Output 1: Input
		0	GPIO5 EN	RW	1	0: TRI-STATE 1: Enabled
23	General Purpose Control Reg	7:0	GPCR[7] GPCR[6] GPCR[5] GPCR[4] GPCR[3] GPCR[2] GPCR[1] GPCR[0]	RW	0x00'h	0: LOW 1: HIGH
24	BIST	0	BIST_EN	RW	0	BIST Enable 0: Normal operation 1: Bist Enable
25	BIST_ERR	7:0	BIST_ERR	R	0x00'h	Bist Error Counter

## Functional Description

The DS90UB901Q/902Q FPD-Link III chipset is intended for camera applications. The Serializer/ Deserializer chipset operates from a 10 MHz to 43 MHz pixel clock frequency. The DS90UB901Q transforms a 16-bit wide parallel LVCMOS data bus along with a bidirectional control bus into a single high-speed differential pair. The high-speed serial bit stream contains an embedded clock and DC-balance information which enhances signal quality to support AC coupling. The DS90UB902Q receives the single serial data stream and converts it back into a 16-bit wide parallel data bus together with the bidirectional control channel data bus.

The bidirectional control channel of the DS90UB901Q/902Q provides bidirectional communication between the image sensor and Electronic Control Unit (ECU) over the same differential pair used for video data interface. This interface offers advantages over other chipsets by eliminating the need for additional wires for programming and control. The bidirectional control channel bus is controlled via an I<sup>2</sup>C port. The bidirectional control channel offers asymmetrical communication and is not dependent on video blanking intervals.

### SERIAL FRAME FORMAT

The DS90UB901Q/902Q chipset will transmit and receive a pixel of data in the following format:

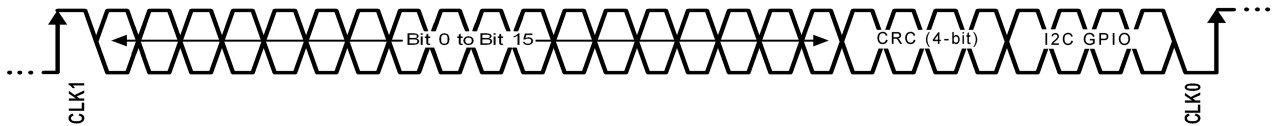

30113561

FIGURE 21. Serial Bitstream for 28-bit Symbol

The High Speed Forward Channel is a 28-bit symbol composed of 16 bits of data containing camera data & control information transmitted from Serializer to Deserializer. CLK1 and CLK0 represent the embedded clock in the serial stream. CLK1 is always HIGH and CLK0 is always LOW. This data payload is optimized for signal transmission over an AC coupled link. Data is randomized, balanced and scrambled. The data payload may be checked using a 4-bit CRC function. The CRC monitors the link integrity of the serialized data and reports when an error condition is detected.

The bidirectional control channel data is transferred along with the high-speed forward data over the same serial link. This architecture provides a full duplex low speed back channel across the serial link together with a high speed forward channel without the dependence of the video blanking phase.

### DESCRIPTION OF BIDIRECTIONAL CONTROL BUS AND I<sup>2</sup>C MODES

The I<sup>2</sup>C compatible interface allows programming of the DS90UB901Q, DS90UB902Q, or an external remote device (such as a camera) through the bidirectional control channel. Register programming transactions to/from the DS90UB901Q/902Q chipset are employed through the clock (SCL) and data (SDA) lines. These two signals have open-drain I/Os and both lines must be pulled-up to VDDIO by external resistor. Figure 4 shows the timing relationships of

the clock (SCL) and data (SDA) signals. Pull-up resistors or current sources are required on the SCL and SDA busses to pull them high when they are not being driven low. A logic zero is transmitted by driving the output low. A logic high is transmitted by releasing the output and allowing it to be pulled-up externally. The appropriate pull-up resistor values will depend upon the total bus capacitance and operating speed. The DS90UB901Q/902Q I<sup>2</sup>C bus data rate supports up to 100 kbps according to I<sup>2</sup>C specification.

To start any data transfer, the DS90UB901Q/902Q must be configured in the proper I<sup>2</sup>C mode. Each device can function as an I<sup>2</sup>C slave proxy or master proxy depending on the mode determined by MODE pin. The Ser/Des interface acts as a virtual bridge between Master controller (MCU) and the remote device. When the MODE pin is set to High, the device is treated as a slave proxy; acts as a slave on behalf of the remote slave. When addressing a remote peripheral or Serializer/Deserializer (not wired directly to the MCU), the slave proxy will forward any byte transactions sent by the Master controller to the target device. When MODE pin is set to Low, the device will function as a master proxy device; acts as a master on behalf of the I<sup>2</sup>C master controller. Note that the devices must have complementary settings for the MODE configuration. For example, if the Serializer MODE pin is set to High then the Deserializer MODE pin must be set to Low and vice-versa.

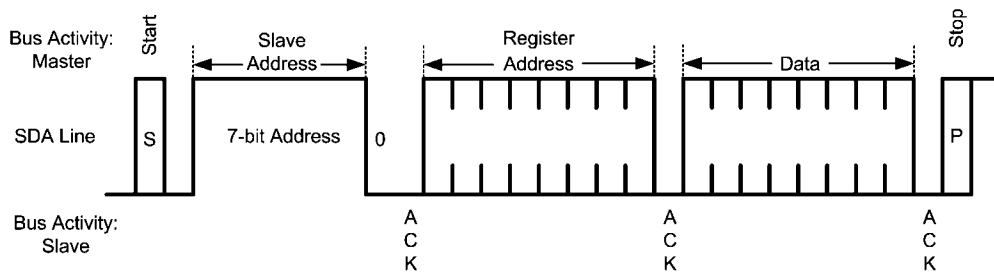

30113560

FIGURE 22. Write Byte

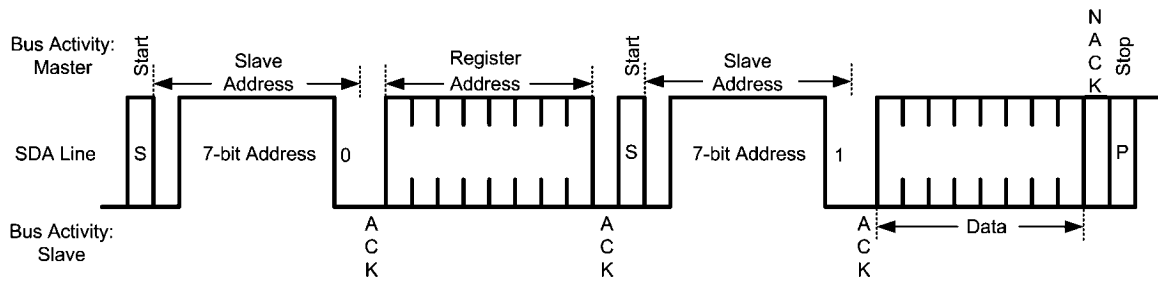

30113510

FIGURE 23. Read Byte

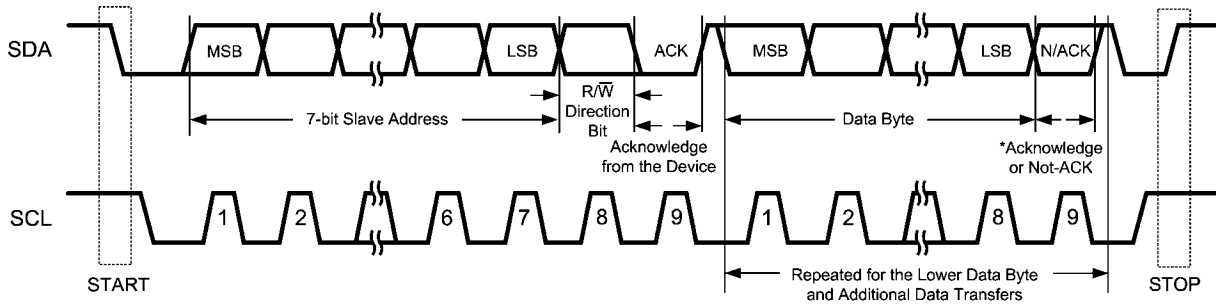

30113541

FIGURE 24. Basic Operation

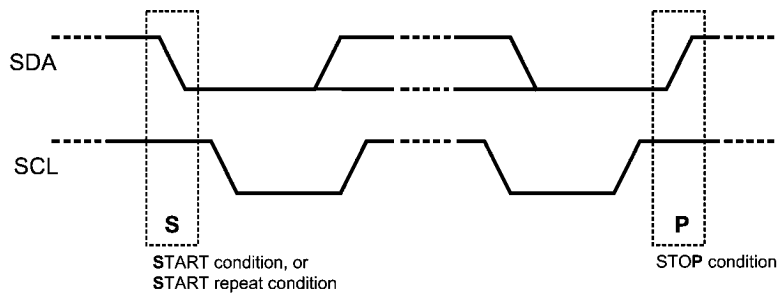

30113542

FIGURE 25. START and STOP Conditions

**SLAVE CLOCK STRETCHING**

In order to communicate and synchronize with remote devices on the I<sup>2</sup>C bus through the bidirectional control channel, slave clock stretching must be supported by the I<sup>2</sup>C master controller/MCU. The chipset utilizes bus clock stretching (holding the SCL line low) during data transmission; where the I<sup>2</sup>C slave pulls the SCL line low prior to the 9th clock of every I<sup>2</sup>C data transfer (before the ACK signal). The slave device will not control the clock and only stretches it until the remote peripheral has responded; which is typically in the order of 12  $\mu$ s (typical).

**ID[x] ADDRESS DECODER**

The ID[x] pin is used to decode and set the physical slave address of the Serializer/Deserializer (I<sup>2</sup>C only) to allow up to six devices on the bus using only a single pin. The pin sets one of six possible addresses for each Serializer/Deserializer device. The pin must be pulled to VDD (1.8V, NOT VDDIO)) with a 10 k $\Omega$  resistor and a pull down resistor (RID) of the recommended value to set the physical device address. The recommended maximum resistor tolerance is 0.1% worst case (0.2% total tolerance).

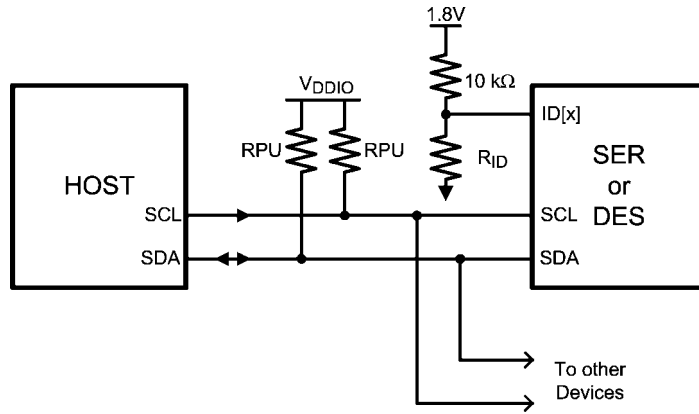

30113543

FIGURE 26. Bidirectional Control Bus Connection

TABLE 3. ID[x] Resistor Value – DS90UB901Q

ID[x] Resistor Value - DS90UB901Q Ser		
Resistor RID Ω (±0.1%)	Address 7'b (Note 11)	Address 8'b 0 appended (WRITE)
0 GND	7b' 101 1000 (h'58)	8b' 1011 0000 (h'B0)
2.0k	7b' 101 1001 (h'59)	8b' 1011 0010 (h'B2)
4.7k	7b' 101 1010 (h'5A)	8b' 1011 0100 (h'B4)
8.2k	7b' 101 1011 (h'5B)	8b' 1011 0110 (h'B6)
12.1k	7b' 101 1100 (h'5C)	8b' 1011 1000 (h'B8)
39.0k	7b' 101 1110 (h'5E)	8b' 1011 1100 (h'BC)

TABLE 4. ID[x] Resistor Value – DS90UB902Q

ID[x] Resistor Value - DS90UB902Q Des		
Resistor RID Ω (±0.1%)	Address 7'b (Note 11)	Address 8'b 0 appended (WRITE)
0 GND	7b' 110 0000 (h'60)	8b' 1100 0000 (h'C0)
2.0k	7b' 110 0001 (h'61)	8b' 1100 0010 (h'C2)
4.7k	7b' 110 0010 (h'62)	8b' 1100 0100 (h'C4)
8.2k	7b' 110 0011 (h'63)	8b' 1101 0110 (h'C6)
12.1k	7b' 110 0100 (h'64)	8b' 1101 1000 (h'C8)
39.0k	7b' 110 0110 (h'66)	8b' 1100 1100 (h'CC)

CAMERA MODE OPERATION

In Camera mode, I<sup>2</sup>C transactions originate from the Master controller at the Deserializer side (Figure 27). The I<sup>2</sup>C slave core in the Deserializer will detect if a transaction is intended for the Serializer or a slave at the Serializer. Commands are sent over the bidirectional control channel to initiate the transactions. The Serializer will receive the command and generate an I<sup>2</sup>C transaction on its local I<sup>2</sup>C bus. At the same time, the Serializer will capture the response on the I<sup>2</sup>C bus and return the response on the forward channel link. The Deserializer parses the response and passes the appropriate response to the Deserializer I<sup>2</sup>C bus.

To configure the devices for camera mode operation, set the Serializer MODE pin to Low and the Deserializer MODE pin to High. Before initiating any I<sup>2</sup>C commands, the Deserializer needs to be programmed with the target slave device addresses and Serializer device address. SER\_DEV\_ID Register 0x07h sets the Serializer device address and SLAVE\_x\_MATCH/SLAVE\_x\_INDEX registers 0x08h~0x17h set the remote target slave addresses. In slave mode the address register is compared with the address byte sent by the I<sup>2</sup>C master. If the addresses are equal to any of registers values, the I<sup>2</sup>C slave will acknowledge and hold the bus to propagate the transaction to the target device otherwise it returns no acknowledge.

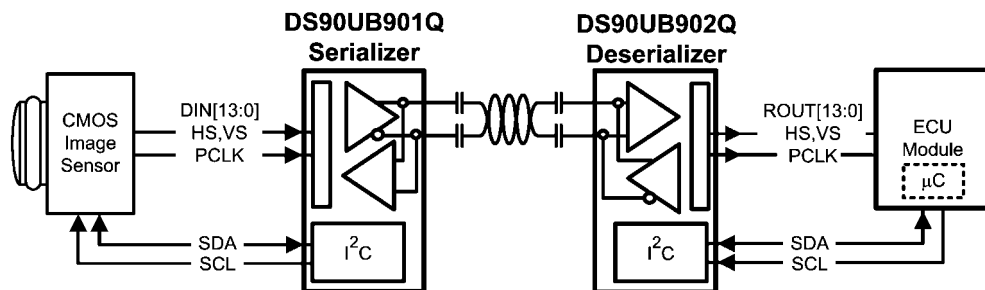

30113540

FIGURE 27. Typical Camera System Diagram

## DISPLAY MODE OPERATION

In Display mode, I<sup>2</sup>C transactions originate from the controller attached to the Serializer. The I<sup>2</sup>C slave core in the Serializer will detect if a transaction targets (local) registers within the Serializer or the (remote) registers within the Deserializer or a remote slave connected to the I<sup>2</sup>C master interface of the Deserializer. Commands are sent over the forward channel link to initiate the transactions. The Deserializer will receive the command and generate an I<sup>2</sup>C transaction on its local I<sup>2</sup>C bus. At the same time, the Deserializer will capture the response on the I<sup>2</sup>C bus and return the response as a command on the bidirectional control channel. The Serializer parses the response and passes the appropriate response to the Serializer I<sup>2</sup>C bus.

The physical device ID of the I<sup>2</sup>C slave in the Serializer is determined by the analog voltage on the ID[x] input. It can be reprogrammed by using the DEVICE\_ID register and setting the bit . The device ID of the logical I<sup>2</sup>C slave in the Deserializer is determined by programming the DES ID in the Serializer. The state of the ID[x] input on the Deserializer is used to set the device ID. The I<sup>2</sup>C transactions between Ser/Des will be bridged between the host controller to the remote slave.

To configure the devices for display mode operation, set the Serializer MODE pin to High and the Deserializer MODE pin to Low. Before initiating any I<sup>2</sup>C commands, the Serializer needs to be programmed with the target slave device address and Serializer device address. DES\_DEV\_ID Register 0x06h sets the Deserializer device address and SLAVE\_DEV\_ID register 0x7h sets the remote target slave address. If the I<sup>2</sup>C slave address matches any of registers values, the I<sup>2</sup>C slave will hold the transaction allowing read or write to target device. Note: In Display mode operation, registers 0x08h~0x17h on Deserializer must be reset to 0x00.

## CRC (CYCLIC REDUNDANCY CHECK) DETECTION

A 4-bit CRC per symbol is reserved for checking the link integrity during transmission. The reporting status pin (PASS) is provided on the Deserializer side, which flags any mismatch of data transmitted to and from the remote device. The Deserializer's PLL must first be locked (LOCK pin HIGH) to ensure the PASS status is valid. This error detection handling generates an interrupt signal onto the PASS output pin; notifying the host controller as soon as any errors are identified. When an error occurs, the PASS asserts LOW. CRC registers (CRC ERROR B0/B1) are also available for managing the data error count.

The DS90UB901Q/902Q chipset provides several mechanisms (operations) for ensuring data integrity in long distance transmission and reception. The data error detection function offers user flexibility and usability of performing bit-by-bit and

data transmission error checking. The error detection operating modes support data validation of the following signals:

- Bidirectional Channel Control
- Control VSYNC and HSYNC signals across serial link
- Parallel video/pixel data across serial link

## PROGRAMMABLE CONTROLLER

An integrated I<sup>2</sup>C slave controller is embedded in each of the DS90UB901Q Serializer and DS90UB902Q Deserializer. It must be used to access and program the extra features embedded within the configuration registers. Refer to [Table 1](#) and [Table 2](#) for details of control registers.

## MULTIPLE DEVICE ADDRESSING

Some applications require multiple camera devices with the same fixed address to be accessed on the same I<sup>2</sup>C bus. The DS90UB901/902 provides slave ID matching/aliasing to generate different target slave addresses when connecting more than two identical devices together on the same bus. This allows the slave devices to be independently addressed. Each device connected to the bus is addressable through a unique ID by programming of the SLAVE\_ID\_MATCH register on Deserializer. This will remap the SLAVE\_ID\_MATCH address to the target SLAVE\_ID\_INDEX address; up to 8 ID indexes are supported. The ECU Controller must keep track of the list of I<sup>2</sup>C peripherals in order to properly address the target device. In a camera application, the microcontroller is located on the Deserializer side. In this case, the microcontroller programs the slave address matching registers and handles all data transfers to and from all slave I<sup>2</sup>C devices. This is useful in the event where camera modules are removed or replaced.

For example in the configuration shown in [Figure 28](#):

- ECU is the I<sup>2</sup>C master and has an I<sup>2</sup>C master interface
- The I<sup>2</sup>C interfaces in DES A and DES B are both slave interfaces
- The I<sup>2</sup>C protocol is bridged from DES A to SER A and from DES B to SER B
- The I<sup>2</sup>C interfaces in SER A and SER B are both master interfaces

If master controller transmits I<sup>2</sup>C slave 0xA0, the DES A address 0xC0 will forward the transaction to remote Camera A. If the controller transmits slave address 0xA4, the DES B 0xC2 will recognize that 0xA4 is mapped to 0xA0 and will be transmitted to the remote Camera B. If controller sends command to address 0xA6, the DES B 0xC2 will forward transaction to slave device 0xA2.

The Slave ID index/match is supported only in the camera mode (SER: MODE pin = L; DES: MODE pin = H). For Multiple device addressing in display mode (SER: MODE pin = H; DES: MODE pin = L), use the I<sup>2</sup>C pass through function.

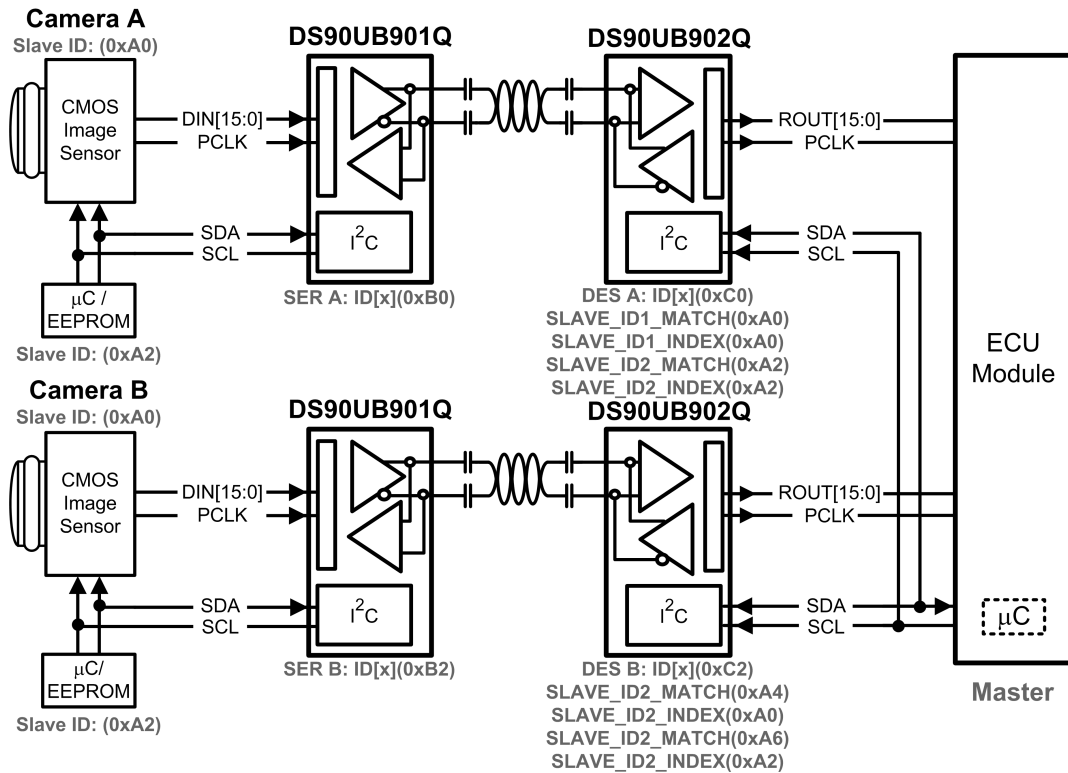

30113533

FIGURE 28. Multiple Device Addressing

### I<sup>2</sup>C PASS THROUGH

I<sup>2</sup>C pass-through provides an alternative means to independently address slave devices. The mode enables or disables I<sup>2</sup>C bidirectional control channel communication to the remote I<sup>2</sup>C bus. This option is used to determine whether or not an I<sup>2</sup>C instruction is to be transferred over to the remote I<sup>2</sup>C device. When enabled, the I<sup>2</sup>C bus traffic will continue to pass through and will be received by I<sup>2</sup>C devices downstream. If disabled, I<sup>2</sup>C commands will be blocked to the remote I<sup>2</sup>C device. The pass through function also provides access and

communication to only specific devices on the remote bus. The feature is effective for both Camera mode and Display mode.

For example in the configuration shown in [Figure 29](#):

If master controller transmits I<sup>2</sup>C transaction for address 0xA0, the SER A with I<sup>2</sup>C pass through enabled will transfer I<sup>2</sup>C commands to remote Camera A. The SER B with I<sup>2</sup>C pass through disabled, any I<sup>2</sup>C commands will be bypassed on the I<sup>2</sup>C bus to Camera B.

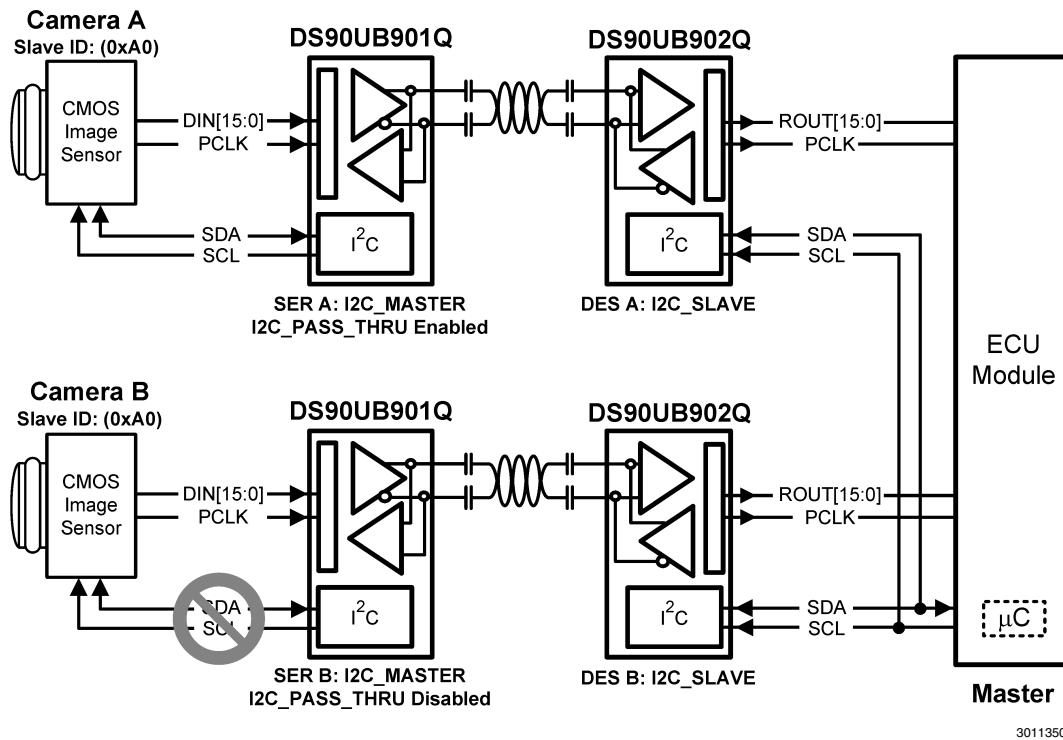

30113504

FIGURE 29. I<sup>2</sup>C Pass Through

### SYNCHRONIZING MULTIPLE CAMERAS

For applications requiring multiple cameras for frame-synchronization, it is recommended to utilize the General Purpose Input/Output (GPIO) pins to transmit control signals to synchronize multiple cameras together. To synchronize the cameras properly, the system controller needs to provide a field sync output (such as a vertical or frame sync signal) and the cameras must be set to accept an auxiliary sync input. The vertical synchronize signal corresponds to the start and end of a frame and the start and end of a field. Note this form of synchronization timing relationship has a non-deterministic latency. After the control data is reconstructed from the birec-

tional control channel, there will be a time variation of the GPIO signals arriving at the different target devices (between the parallel links). The maximum latency delta ( $t_1$ ) of the GPIO data transmitted across multiple links is 25  $\mu$ s.

Note: The user must verify that the timing variations between the different links are within their system and timing specifications.

For example in the configuration shown in (Figure 30):

The maximum time ( $t_1$ ) between the rising edge of GPIO (i.e. sync signal) arriving at Camera A and Camera B is 25  $\mu$ s.

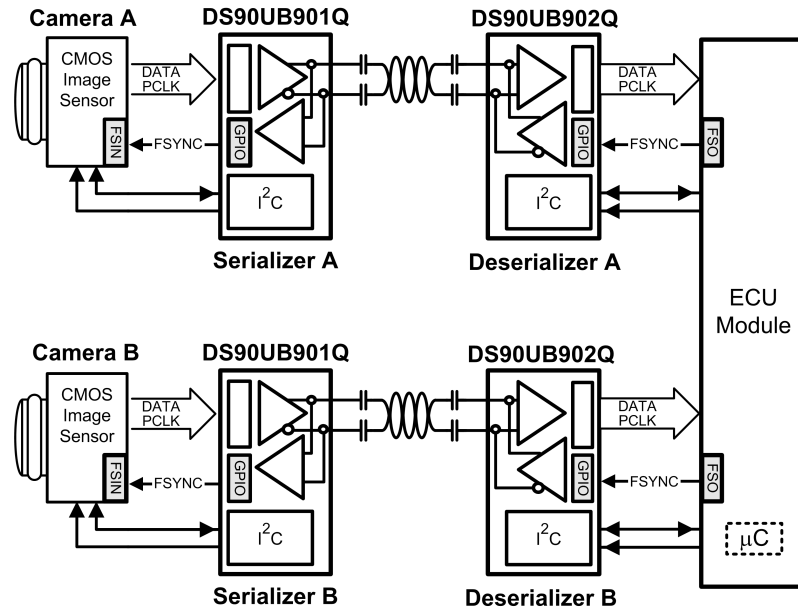

30113553

FIGURE 30. Synchronizing Multiple Cameras

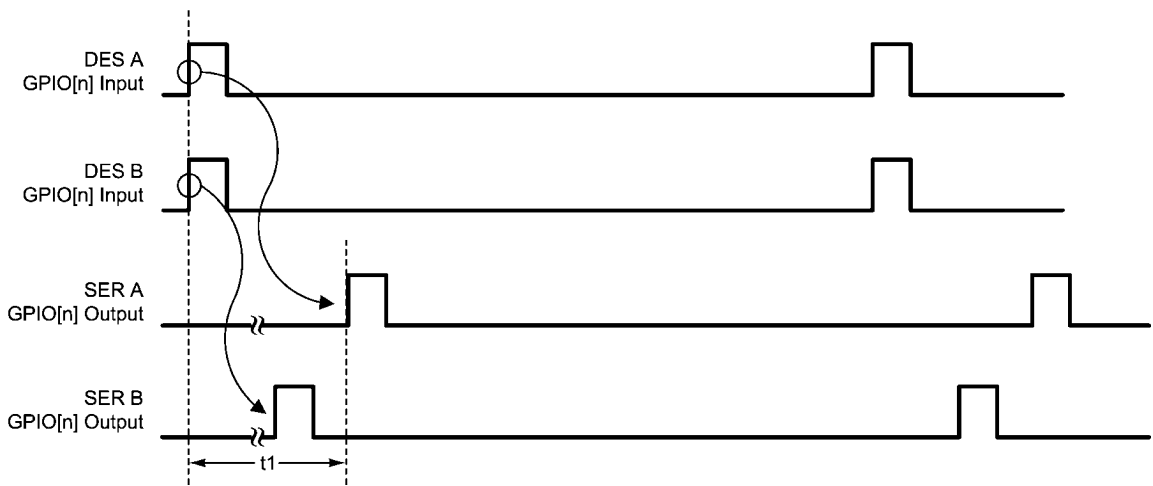

30113554

FIGURE 31. GPIO Delta Latency

**GENERAL PURPOSE I/O (GPIO)**

The DS90UB901Q/902Q has up to 6 GPIO (2 dedicated and 4 programmable). GPIO[0] and GPIO[1] are always available and GPIO[2:5] are available depending on the parallel data bus size. DIN/ROUT[0:3] can be programmed into GPIOs (GPIO[2:5]) when the parallel data bus is less than 12 bits wide (10-bit data + HS,VS). Each GPIO can be configured as either an input or output port. The GPIO maximum switching rate is up to 66 kHz when configured for communication between Deserializer GPI to Serializer GPO. Whereas data flow configured for communication between Serializer GPI to Deserializer GPO is limited by the maximum data rate of the PCLK.

**AT-SPEED BIST (BISTEN, PASS)**

An optional AT SPEED Built in Self Test (BIST) feature supports at speed testing of the high-speed serial and the bidirectional control channel link. Control pins at the Deserializer are used to enable the BIST test mode and allow the system to initiate the test and set the duration. A HIGH on PASS pin indicates that all payloads received during the test were error free during the BIST duration test. A LOW on this pin at the conclusion of the test indicates that one or more payloads were detected with errors.

The BIST duration is defined by the width of BISTEN. BIST starts when Deserializer LOCK goes HIGH and BISTEN is set HIGH. BIST ends when BISTEN goes LOW. Any errors detected after the BIST Duration are not included in PASS logic.

Note: AT-SPEED BIST is only available in the Camera mode and not the Display mode

The following diagram shows how to perform system AT SPEED BIST:

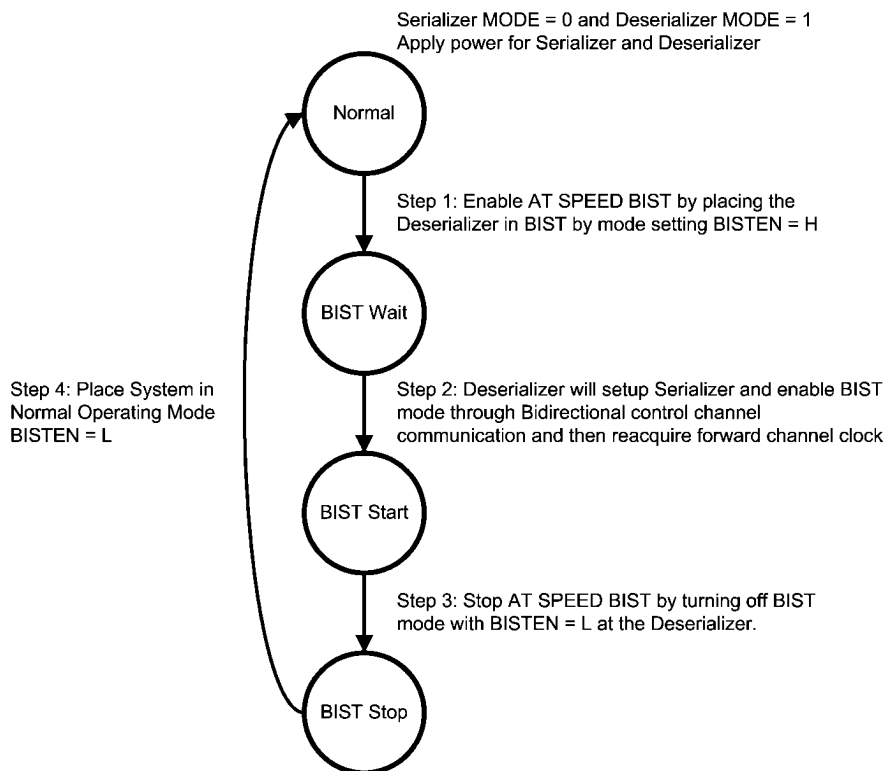

30113545

**FIGURE 32. AT-SPEED BIST System Flow Diagram**

**Step 1: Place the Deserializer in BIST Mode.**

Serializer and Deserializer power supply must be supplied. Enable the AT SPEED BIST mode on the Deserializer by setting the BISTEN pin High. The 902 GPIO[1:0] pins are used to select the PCLK frequency of the on-chip oscillator for the BIST test on high speed data path.

**TABLE 5. BIST Oscillator Frequency Select**

Des GPIO [1:0]	Oscillator Source	min (MHz)	typ (MHz)	max (MHz)
00	External PCLK	10		43
01	Internal		50	
10	Internal		25	
11	Internal		12.5	

The Deserializer GPIO[1:0] set to 00 will bypass the on-chip oscillator and an external oscillator to Serializer PCLK input is required. This allows the user to operate BIST under different frequencies other than the predefined ranges.

**Step 2: Enable AT SPEED BIST by placing the Serializer into BIST mode.**

Deserializer will communicate through the bidirectional control channel to configure Serializer into BIST mode. Once the BIST mode is set, the Serializer will initiate BIST transmission to the Deserializer.

Wait 10 ms for Deserializer to acquire lock and then monitor the LOCK pin transition from LOW to HIGH. At this point, AT SPEED BIST is operational and the BIST process has begun. The Serializer will start transfer of an internally generated PRBS data pattern through the high speed serial link. This pattern traverses across the interconnecting link to the Deserializer. Check the status of the PASS pin; a HIGH indicates a pass, a LOW indicates a fail. A fail will stay LOW for 1/2 a clock cycle. If two or more bits in the serial frame fail, the PASS pin will toggle 1/2 clock cycle HIGH and 1/2 clock cycle low. The user can use the PASS pin to count the number of fails on the high speed link. In addition, there is a defined SER and DES register that will keep track of the accumulated error count. The Serializer 901 GPIO[0] pin will be assigned as a PASS flag error indicator for the bidirectional control link.

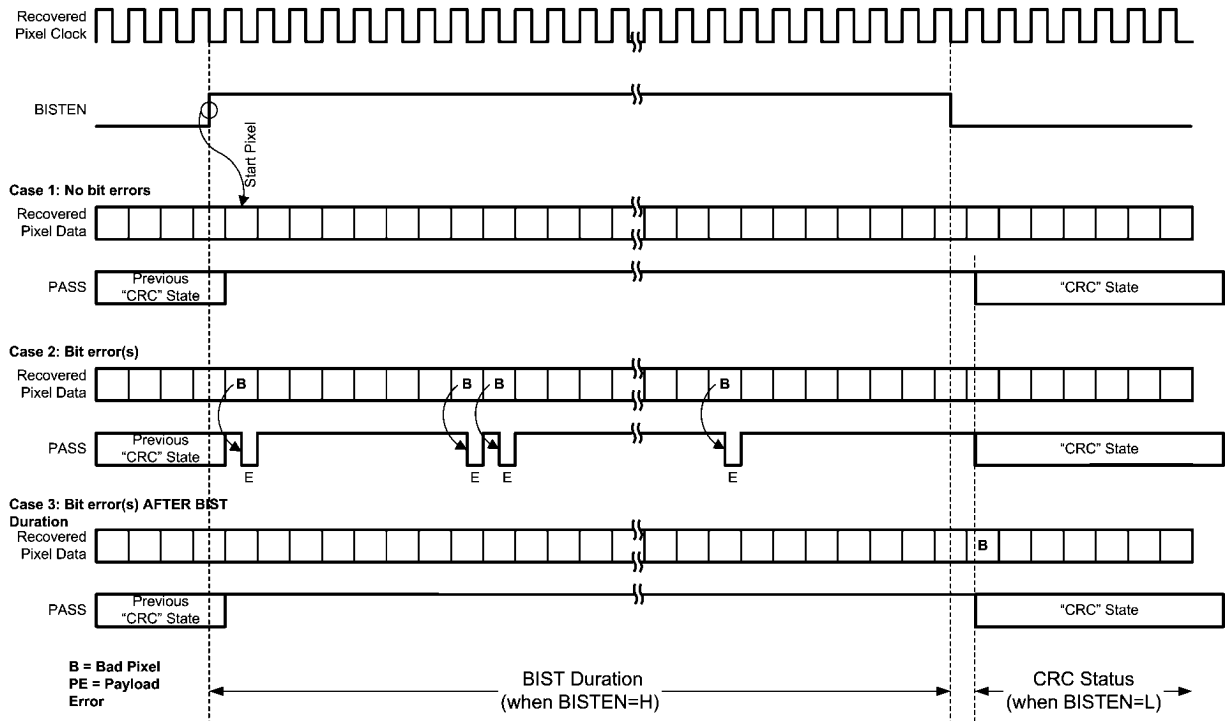

30113564

**FIGURE 33. BIST Timing Diagram**

*Step 3: Stop at SPEED BIST by turning off BIST mode in the Deserializer to determine Pass/Fail.*

To end BIST, the system must pull BISTEN pin of the Deserializer LOW. The BIST duration is fully defined by the BISTEN

TEN width and Deserializer LOCK is HIGH; thus the Bit Error Rate is determined by how long the system holds BISTEN HIGH.

$$\frac{\text{BIST Duration (s)}}{1 \text{ Pixel period (ns)} \times \text{Total Bits}} = \text{BIST Duration (s)} \times \frac{f_{\text{pixel}} \text{ (MHz)}}{\text{Pixel}} \times \text{Total Pixels Transmitted} = \text{Total Bits Transmitted}$$

- Bit (Pixel) Error Rate = [Total Bits Transmitted]<sup>-1</sup>
- (for passing BIST) = [Total Bits Transmitted x Bits/Pixel]<sup>-1</sup>

30113505

**FIGURE 34. BIST BER Calculation**

For instance, if BISTEN is held HIGH for 1 second and the PCLK is running at 43 MHz with 16 bpp, then the Bit Error Rate is no better than 1.46E-9.

*Step 4: Place system in Normal Operating Mode by disabling BIST at the Serializer.*

Once Step 3 is complete, AT SPEED BIST is over and the Deserializer is out of BIST mode. To fully return to Normal mode, apply Normal input data into the Serializer.

Any PASS result will remain unless it is changed by a new BIST session or cleared by asserting and releasing PDB. The default state of PASS after a PDB toggle is HIGH.

It is important to note that AT SPEED BIST will only determine if there is an issue on the link that is not related to the clock and data recovery of the link (whose status is flagged with LOCK pin).

**LVC MOS VDDIO OPTION**

1.8V or 3.3V SER Inputs and DES Outputs are user selectable to provide compatibility with 1.8V and 3.3V system interfaces.

**REMOTE WAKE**

After initial power up, the SER is in a low-power Standby mode. The DES (controlled by ECU/MCU) 'Remote Wakeup' register allows the DES side to generate a signal across the link to remotely wakeup the SER. Once the SER detects the wakeup signal SER switches from Standby mode to active mode. In active mode, the SER locks onto PCLK input (if present), otherwise the on-chip oscillator is used as the input clock source. Note the MCU controller should monitor the LOCK pin and confirm LOCK = H before performing any I<sup>2</sup>C communication across the link.

For Remote Wakeup to function properly:

- The chipset needs to be configured in Camera mode:  
Serializer MODE = 0 and Deserializer MODE = 1
- Serializer is in remote wakeup mode by default at power on. The Remote Wakeup feature is enabled on Serializer: Register 0x01 b[2] = 0 (default)

Serializer can also be put into standby mode by programming the Deserializer remote wakeup control register 0x01 b[2] REM\_WAKEUP to 0.

### POWERDOWN

The SER has a PDB input pin to ENABLE or Powerdown the device. The modes can be controlled by the host and is used to disable the Link to save power when the remote device is not operational. An auto mode is also available. In this mode, the PDB pin is tied High and the SER switches over to an internal oscillator when the PCLK stops or not present. When a PCLK starts again, the SER will then lock to the valid input PCLK and transmits the data to the DES. In powerdown mode, the high-speed driver outputs are static (High).

The DES has a PDB input pin to ENABLE or Powerdown the device. This pin can be controlled by the system and is used to disable the DES to save power. An auto mode is also available. In this mode, the PDB pin is tied High and the DES will enter powerdown when the serial stream stops. When the serial stream starts up again, the DES will lock to the input stream and assert the LOCK pin and output valid data. In powerdown mode, the Data and PCLK outputs are set by the OSS\_SEL control register.

### POWER UP REQUIREMENTS AND PDB PIN

It is required to delay and release the PDB input signal after VDD (VDDn and VDDIO) power supplies have settled to the recommended operating voltages. A external RC network can be connected to the PDB pin to ensure PDB arrives after all the VDD have stabilized.

### SIGNAL QUALITY ENHANCERS

#### Des - Receiver Input Equalization (EQ)

The receiver inputs provided input equalization filter in order to compensate for loss from the media. The level of equalization is controlled via register setting.

### EMI REDUCTION

#### Des - Receiver Staggered Output

The Receiver staggered outputs allows for outputs to switch in a random distribution of transitions within a defined window. Outputs transitions are distributed randomly. This minimizes the number of outputs switching simultaneously and helps to reduce supply noise. In addition it spreads the noise spectrum out reducing overall EMI.

#### Des Spread Spectrum Clocking

The DS90UB902Q parallel data and clock outputs have programmable SSCG ranges from 9 kHz–66 kHz and  $\pm 0.5\%$ – $\pm 2\%$  from 20 MHz to 43 MHz. The modulation rate and modulation frequency variation of output spread is controlled through the SSC control registers.

#### PIXEL CLOCK EDGE SELECT (TRFB/RRFB)

The TRFB/RRFB selects which edge of the Pixel Clock is used. For the SER, this register determines the edge that the data is latched on. If TRFB register is 1, data is latched on the Rising edge of the PCLK. If TRFB register is 0, data is latched on the Falling edge of the PCLK. For the DES, this register determines the edge that the data is strobed on. If RRFB register is 1, data is strobed on the Rising edge of the PCLK. If RRFB register is 0, data is strobed on the Falling edge of the PCLK.

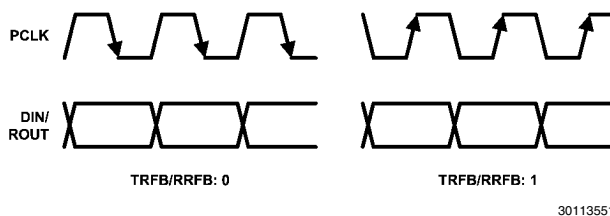

FIGURE 35. Programmable PCLK Strobe Select

30113551

# Applications Information

nal AC coupling capacitors must be placed in series in the FPD-Link III signal path as illustrated in *Figure 36*.

## AC COUPLING

The SER/DES supports only AC-coupled interconnects through an integrated DC balanced decoding scheme. Exter-

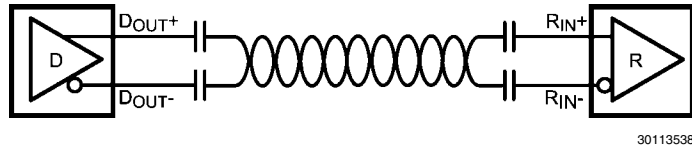

FIGURE 36. AC-Coupled Connection

For high-speed FPD-Link III transmissions, the smallest available package should be used for the AC coupling capacitor. This will help minimize degradation of signal quality due to package parasitics. The I/O's require a 100 nF AC coupling capacitors to the line.

## TYPICAL APPLICATION CONNECTION

*Figure 37* shows a typical connection of the DS90UB901Q Serializer.

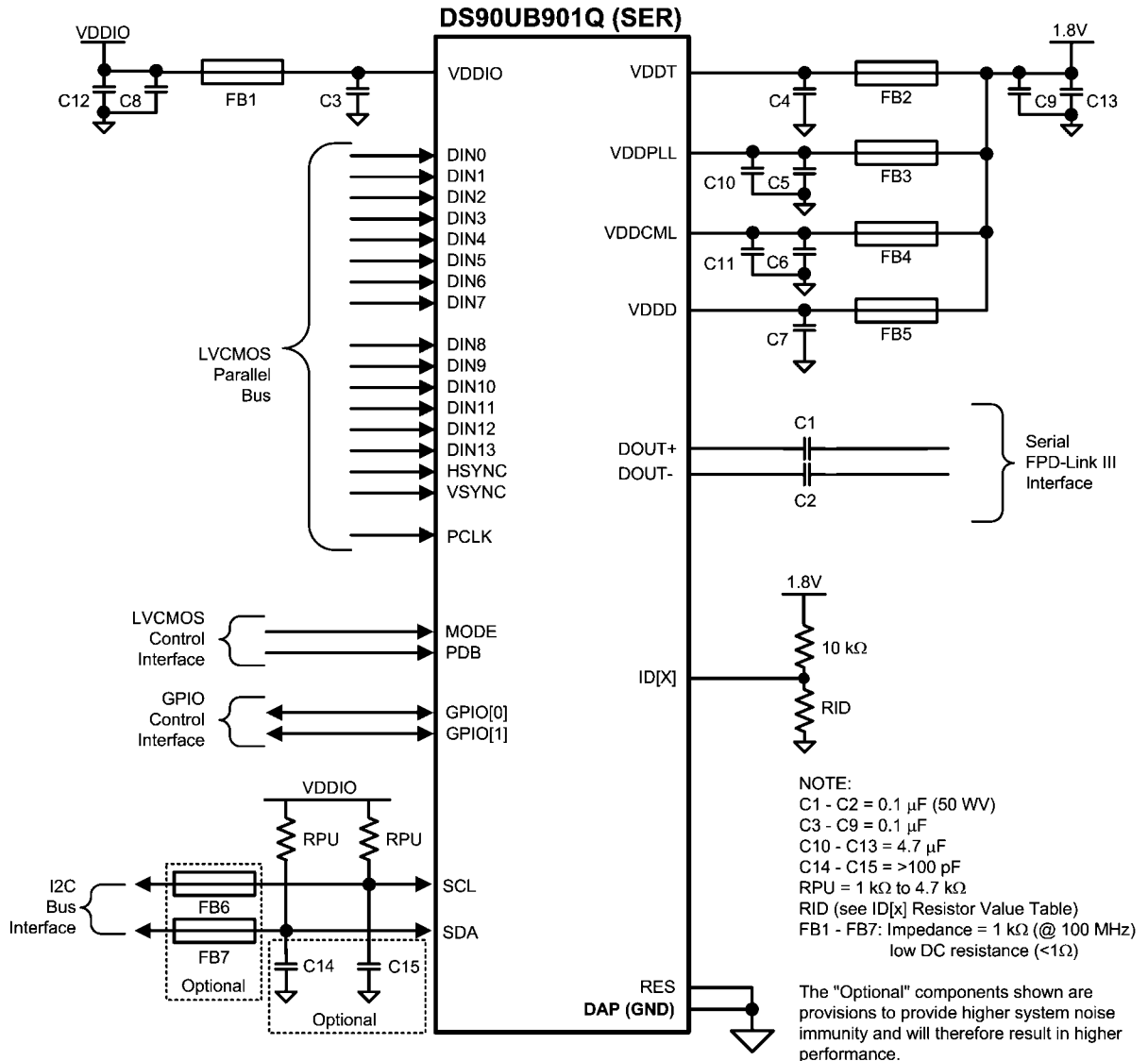
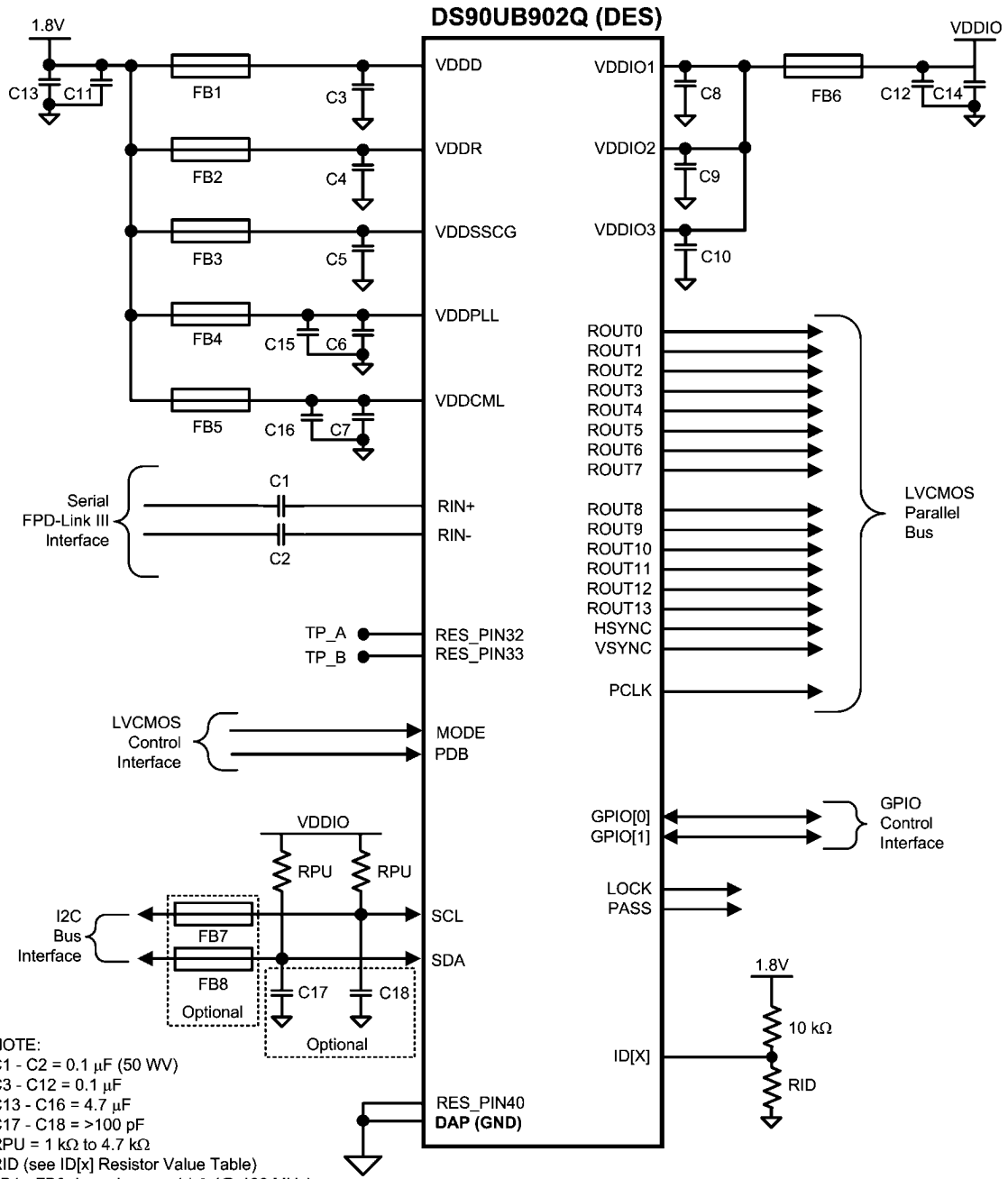

FIGURE 37. DS90UB901Q Typical Connection Diagram — Pin Control

Figure 38 shows a typical connection of the DS90UB902Q Deserializer.



NOTE:  
 C1 - C2 = 0.1  $\mu$ F (50 WV)  
 C3 - C12 = 0.1  $\mu$ F  
 C13 - C16 = 4.7  $\mu$ F  
 C17 - C18 = >100 pF  
 RPU = 1 k $\Omega$  to 4.7 k $\Omega$   
 RID (see ID[x] Resistor Value Table)  
 FB1 - FB8: Impedance = 1 k $\Omega$  (@ 100 MHz)  
 low DC resistance (<1 $\Omega$ )

The "Optional" components shown are provisions to provide higher system noise immunity and will therefore result in higher performance.

30113556

FIGURE 38. DS90UB902Q Typical Connection Diagram — Pin Control

## TRANSMISSION MEDIA

The Ser/Des chipset is intended to be used over a wide variety of balanced cables depending on distance and signal quality requirements. The Ser/Des employ internal termination providing a clean signaling environment. The interconnect for FPD-Link III interface should present a differential impedance of 100 Ohms. Use of cables and connectors that have matched differential impedance will minimize impedance discontinuities. Shielded or un-shielded cables may be used depending upon the noise environment and application requirements. The chipset's optimum cable drive performance is achieved at 43 MHz at 10 meters length. The maximum signaling rate increases as the cable length decreases. Therefore, the chipset supports 50 MHz at shorter distances.

Other cable parameters that may limit the cable's performance boundaries are: cable attenuation, near-end crosstalk and pair-to-pair skew.

For obtaining optimal performance, we recommend:

- Use Shielded Twisted Pair (STP) cable
- 100Ω differential impedance and 24 AWG (or lower AWG) cable
- Low skew, impedance matched
- Ground and/or terminate unused conductors

Figure 39 shows the Typical Performance Characteristics demonstrating various lengths and data rates using Rosenberger HSD and Leoni DACAR 538 Cable.

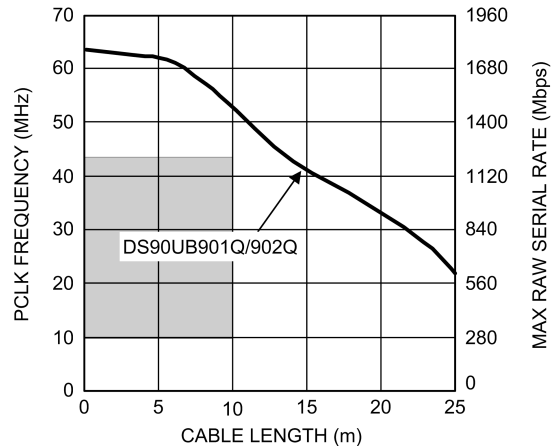

30113557

\*Note: Equalization is enabled for cable lengths greater than 7 meters

**FIGURE 39. Rosenberger HSD & Leoni DACAR 538 Cable Performance**

## PCB LAYOUT AND POWER SYSTEM CONSIDERATIONS

Circuit board layout and stack-up for the Ser/Des devices should be designed to provide low-noise power feed to the device. Good layout practice will also separate high frequency or high-level inputs and outputs to minimize unwanted stray noise pickup, feedback and interference. Power system performance may be greatly improved by using thin dielectrics (2 to 4 mils) for power / ground sandwiches. This arrangement provides plane capacitance for the PCB power system with low-inductance parasitics, which has proven especially effective at high frequencies, and makes the value and placement of external bypass capacitors less critical. External bypass capacitors should include both RF ceramic and tantalum electrolytic types. RF capacitors may use values in the range of 0.01 uF to 0.1 uF. Tantalum capacitors may be in the 2.2 uF to 10 uF range. Voltage rating of the tantalum capacitors should be at least 5X the power supply voltage being used.

Surface mount capacitors are recommended due to their smaller parasitics. When using multiple capacitors per supply pin, locate the smaller value closer to the pin. A large bulk capacitor is recommended at the point of power entry. This is typically in the 50uF to 100uF range and will smooth low frequency switching noise. It is recommended to connect power and ground pins directly to the power and ground planes with bypass capacitors connected to the plane with via on both ends of the capacitor. Connecting power or ground pins to an external bypass capacitor will increase the inductance of the path.

A small body size X7R chip capacitor, such as 0603, is recommended for external bypass. Its small body size reduces the parasitic inductance of the capacitor. The user must pay attention to the resonance frequency of these external bypass capacitors, usually in the range of 20-30 MHz. To provide effective bypassing, multiple capacitors are often used to achieve low impedance between the supply rails over the frequency of interest. At high frequency, it is also a common practice to use two vias from power and ground pins to the planes, reducing the impedance at high frequency.

Some devices provide separate power for different portions of the circuit. This is done to isolate switching noise effects between different sections of the circuit. Separate planes on the PCB are typically not required. Pin Description tables typically provide guidance on which circuit blocks are connected to which power pin pairs. In some cases, an external filter may be used to provide clean power to sensitive circuits such as PLLs.

Use at least a four layer board with a power and ground plane. Locate LVCMOS signals away from the differential lines to prevent coupling from the LVCMOS lines to the differential lines. Closely-coupled differential lines of 100 Ohms are typically recommended for differential interconnect. The closely coupled lines help to ensure that coupled noise will appear as common-mode and thus is rejected by the receivers. The tightly coupled lines will also radiate less.

Information on the LLP style package is provided in National Application Note: AN-1187.

### INTERCONNECT GUIDELINES

See AN-1108 and AN-905 for full details.

- Use 100 $\Omega$  coupled differential pairs
- Use the S/2S/3S rule in spacings
  - S = space between the pair
  - 2S = space between pairs
  - 3S = space to LVCMOS signal
- Minimize the number of Vias

- Use differential connectors when operating above 500Mbps line speed
- Maintain balance of the traces
- Minimize skew within the pair

Additional general guidance can be found in the LVDS Owner's Manual - available in PDF format from the National web site at: [www.national.com/lvds](http://www.national.com/lvds)

**Physical Dimensions** inches (millimeters) unless otherwise noted

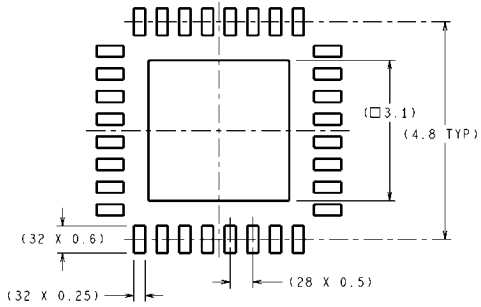

RECOMMENDED LAND PATTERN

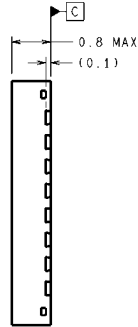
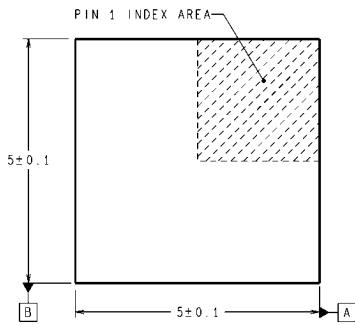

DIMENSIONS ARE IN MILLIMETERS  
DIMENSIONS IN ( ) FOR REFERENCE ONLY

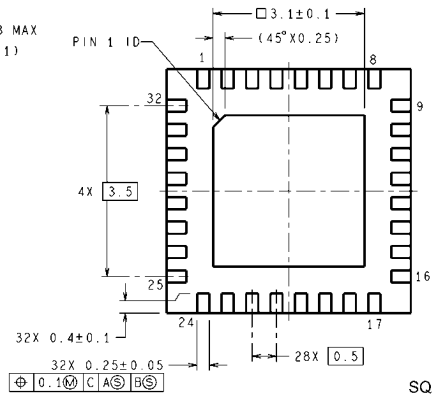
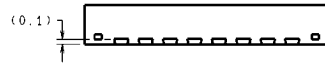

SQA32A (Rev B)

**DS90UB901Q Serializer**  
**NS Package Number SQA32A**

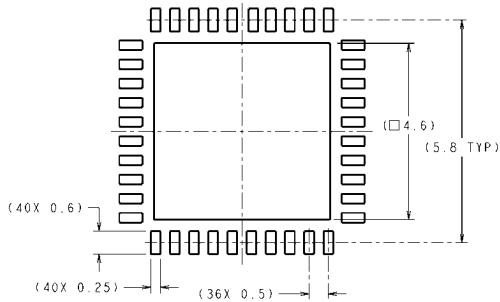

RECOMMENDED LAND PATTERN

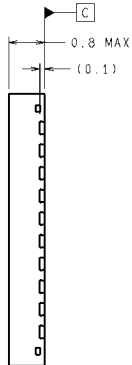
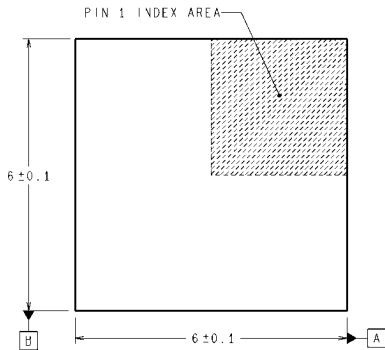

DIMENSIONS ARE IN MILLIMETERS  
DIMENSIONS IN ( ) FOR REFERENCE ONLY

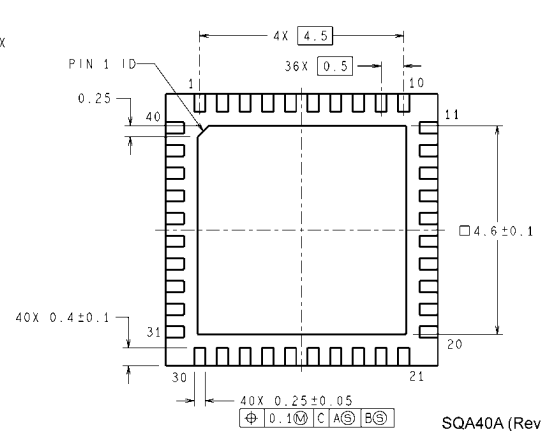
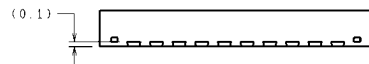

SQA40A (Rev B)

**DS90UB902Q Deserializer**  
**NS Package Number SQA40A**

# Notes

## Notes

For more National Semiconductor product information and proven design tools, visit the following Web sites at:  
[www.national.com](http://www.national.com)

Products		Design Support	
Amplifiers	<a href="http://www.national.com/amplifiers">www.national.com/amplifiers</a>	WEBENCH® Tools	<a href="http://www.national.com/webench">www.national.com/webench</a>
Audio	<a href="http://www.national.com/audio">www.national.com/audio</a>	App Notes	<a href="http://www.national.com/appnotes">www.national.com/appnotes</a>
Clock and Timing	<a href="http://www.national.com/timing">www.national.com/timing</a>	Reference Designs	<a href="http://www.national.com/refdesigns">www.national.com/refdesigns</a>
Data Converters	<a href="http://www.national.com/adc">www.national.com/adc</a>	Samples	<a href="http://www.national.com/samples">www.national.com/samples</a>
Interface	<a href="http://www.national.com/interface">www.national.com/interface</a>	Eval Boards	<a href="http://www.national.com/evalboards">www.national.com/evalboards</a>
LVDS	<a href="http://www.national.com/lvds">www.national.com/lvds</a>	Packaging	<a href="http://www.national.com/packaging">www.national.com/packaging</a>
Power Management	<a href="http://www.national.com/power">www.national.com/power</a>	Green Compliance	<a href="http://www.national.com/quality/green">www.national.com/quality/green</a>
Switching Regulators	<a href="http://www.national.com/switchers">www.national.com/switchers</a>	Distributors	<a href="http://www.national.com/contacts">www.national.com/contacts</a>
LDOs	<a href="http://www.national.com/ldo">www.national.com/ldo</a>	Quality and Reliability	<a href="http://www.national.com/quality">www.national.com/quality</a>
LED Lighting	<a href="http://www.national.com/led">www.national.com/led</a>	Feedback/Support	<a href="http://www.national.com/feedback">www.national.com/feedback</a>
Voltage References	<a href="http://www.national.com/vref">www.national.com/vref</a>	Design Made Easy	<a href="http://www.national.com/easy">www.national.com/easy</a>
PowerWise® Solutions	<a href="http://www.national.com/powerwise">www.national.com/powerwise</a>	Applications & Markets	<a href="http://www.national.com/solutions">www.national.com/solutions</a>
Serial Digital Interface (SDI)	<a href="http://www.national.com/sdi">www.national.com/sdi</a>	Mil/Aero	<a href="http://www.national.com/milaero">www.national.com/milaero</a>
Temperature Sensors	<a href="http://www.national.com/tempensors">www.national.com/tempensors</a>	SolarMagic™	<a href="http://www.national.com/solarmagic">www.national.com/solarmagic</a>
PLL/VCO	<a href="http://www.national.com/wireless">www.national.com/wireless</a>	PowerWise® Design University	<a href="http://www.national.com/training">www.national.com/training</a>

THE CONTENTS OF THIS DOCUMENT ARE PROVIDED IN CONNECTION WITH NATIONAL SEMICONDUCTOR CORPORATION ("NATIONAL") PRODUCTS. NATIONAL MAKES NO REPRESENTATIONS OR WARRANTIES WITH RESPECT TO THE ACCURACY OR COMPLETENESS OF THE CONTENTS OF THIS PUBLICATION AND RESERVES THE RIGHT TO MAKE CHANGES TO SPECIFICATIONS AND PRODUCT DESCRIPTIONS AT ANY TIME WITHOUT NOTICE. NO LICENSE, WHETHER EXPRESS, IMPLIED, ARISING BY ESTOPPEL OR OTHERWISE, TO ANY INTELLECTUAL PROPERTY RIGHTS IS GRANTED BY THIS DOCUMENT.

TESTING AND OTHER QUALITY CONTROLS ARE USED TO THE EXTENT NATIONAL DEEMS NECESSARY TO SUPPORT NATIONAL'S PRODUCT WARRANTY. EXCEPT WHERE MANDATED BY GOVERNMENT REQUIREMENTS, TESTING OF ALL PARAMETERS OF EACH PRODUCT IS NOT NECESSARILY PERFORMED. NATIONAL ASSUMES NO LIABILITY FOR APPLICATIONS ASSISTANCE OR BUYER PRODUCT DESIGN. BUYERS ARE RESPONSIBLE FOR THEIR PRODUCTS AND APPLICATIONS USING NATIONAL COMPONENTS. PRIOR TO USING OR DISTRIBUTING ANY PRODUCTS THAT INCLUDE NATIONAL COMPONENTS, BUYERS SHOULD PROVIDE ADEQUATE DESIGN, TESTING AND OPERATING SAFEGUARDS.

EXCEPT AS PROVIDED IN NATIONAL'S TERMS AND CONDITIONS OF SALE FOR SUCH PRODUCTS, NATIONAL ASSUMES NO LIABILITY WHATSOEVER, AND NATIONAL DISCLAIMS ANY EXPRESS OR IMPLIED WARRANTY RELATING TO THE SALE AND/OR USE OF NATIONAL PRODUCTS INCLUDING LIABILITY OR WARRANTIES RELATING TO FITNESS FOR A PARTICULAR PURPOSE, MERCHANTABILITY, OR INFRINGEMENT OF ANY PATENT, COPYRIGHT OR OTHER INTELLECTUAL PROPERTY RIGHT.

#### LIFE SUPPORT POLICY

**NATIONAL'S PRODUCTS ARE NOT AUTHORIZED FOR USE AS CRITICAL COMPONENTS IN LIFE SUPPORT DEVICES OR SYSTEMS WITHOUT THE EXPRESS PRIOR WRITTEN APPROVAL OF THE CHIEF EXECUTIVE OFFICER AND GENERAL COUNSEL OF NATIONAL SEMICONDUCTOR CORPORATION.** As used herein:

Life support devices or systems are devices which (a) are intended for surgical implant into the body, or (b) support or sustain life and whose failure to perform when properly used in accordance with instructions for use provided in the labeling can be reasonably expected to result in a significant injury to the user. A critical component is any component in a life support device or system whose failure to perform can be reasonably expected to cause the failure of the life support device or system or to affect its safety or effectiveness.

National Semiconductor and the National Semiconductor logo are registered trademarks of National Semiconductor Corporation. All other brand or product names may be trademarks or registered trademarks of their respective holders.

Copyright© 2010 National Semiconductor Corporation

For the most current product information visit us at [www.national.com](http://www.national.com)



**National Semiconductor Americas Technical Support Center**  
 Email: [support@nsc.com](mailto:support@nsc.com)  
 Tel: 1-800-272-9959

**National Semiconductor Europe Technical Support Center**  
 Email: [europe.support@nsc.com](mailto:europe.support@nsc.com)

**National Semiconductor Asia Pacific Technical Support Center**  
 Email: [ap.support@nsc.com](mailto:ap.support@nsc.com)

**National Semiconductor Japan Technical Support Center**  
 Email: [jpn.feedback@nsc.com](mailto:jpn.feedback@nsc.com)