

NOTES:

1. MATERIAL: .032 THICK, NICKEL PLATED STEEL,
#2 TEMPER (1/2 HARD)
PER ETCO METAL CODE 03313.

P/C	DESCRIPTION
07891	M3W-NPS

Rev.	Description of Change/ SCN#	Date
1	REDRAWN ON SOLIDWORKS NO CHANGES SCJ ORG.ENG.DWG.DATE: 5-14-81	1-24-08

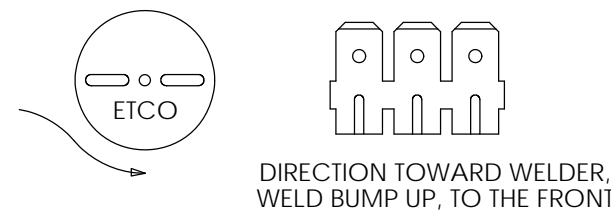
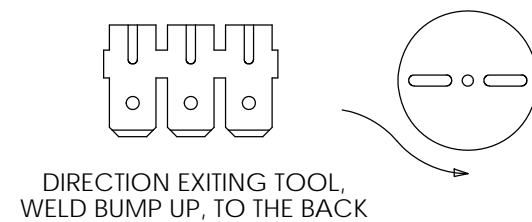
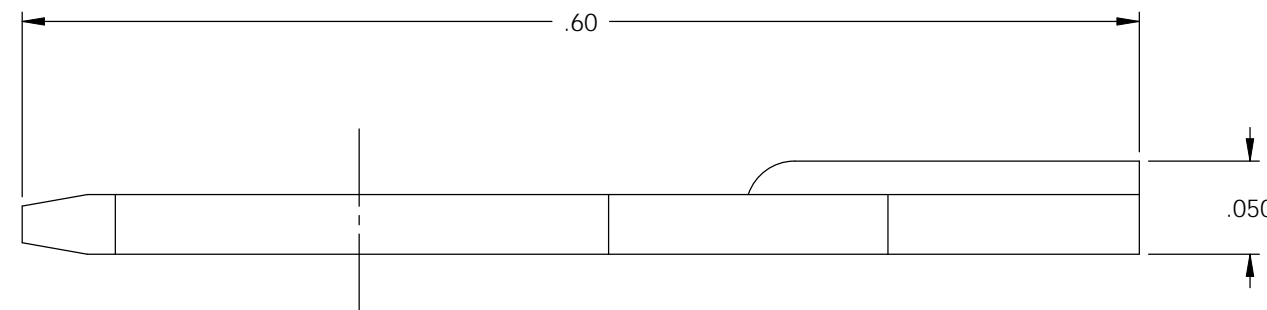
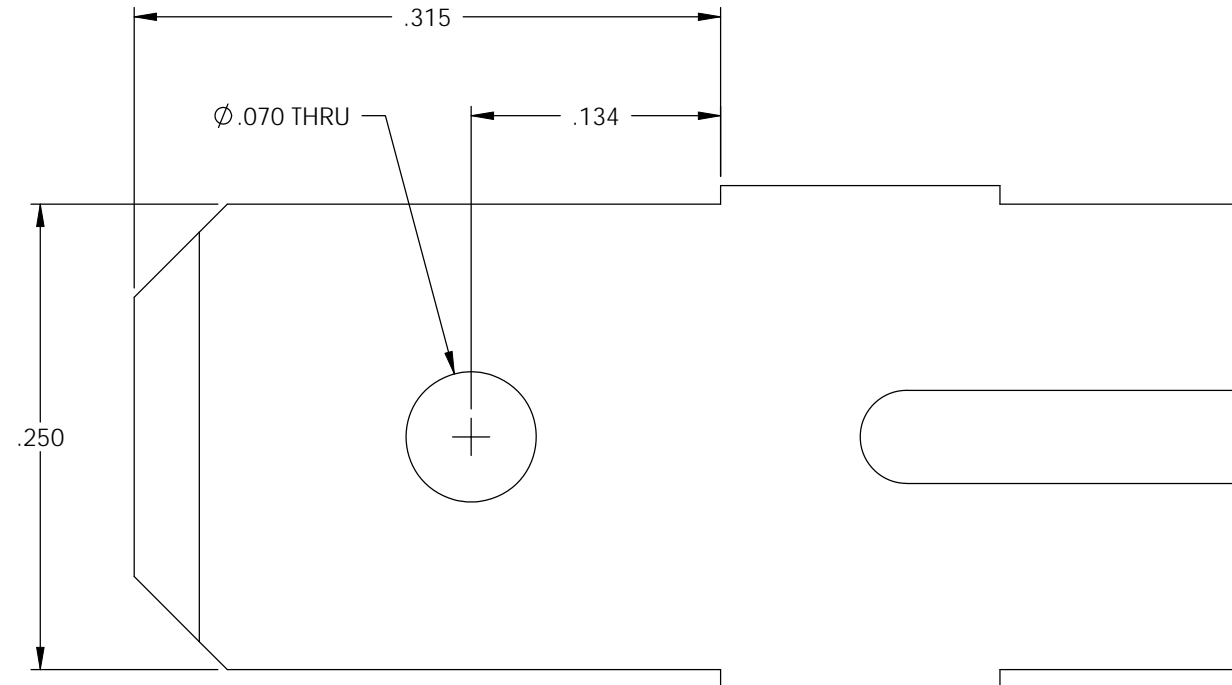

UNCONTROLLED COPY

<p>THIRD ANGLE PROJECTION TOLERANCES UNLESS OTHERWISE SPECIFIED INCHES: .XX - ±.030 .XXX - ±.015 ANGLES: ±5°</p>	<p>TOOL NO. 0135</p>	<p>Title: .032 X .250 WELDING MALE DISCONNECT</p>		
		<p>DO NOT SCALE DWG.</p>	<p>Drawn By: S.JOHNSON</p>	<p>Date: 1-24-08</p>
<p>ETCO Incorporated Engineered Products 25 Bellows Street Warwick, RI 02888 Phone: (401) 467-2400 Fax: (401) 467-9230 www.ETCO.com</p>		<p>Chk'd/App'd By:</p>	<p>Scale: 10X</p>	<p>Size: B</p>
		<p>Dwg. No.: M3W cust</p>		