

## Device connector, front mounting - RC-1RP1N122300 - 1603027

Please be informed that the data shown in this PDF Document is generated from our Online Catalog. Please find the complete data in the user's documentation. Our General Terms of Use for Downloads are valid (<http://phoenixcontact.com/download>)



Device connector, front mounting, RC, straight, shielded: yes, Screw locking, M23, Flat gasket, 4x Ø 3.2

The figure shows the 12-pos. product version



### Key Commercial Data

Packing unit	40 pc
GTIN	 4 046356 243001
GTIN	4046356243001

### Technical data

#### Environmental Product Compliance

China RoHS	Environmentally Friendly Use Period = 50 years
	For information on hazardous substances, refer to the manufacturer's declaration available under "Downloads"

### Drawings

## Device connector, front mounting - RC-1RP1N122300 - 1603027

Dimensional drawing

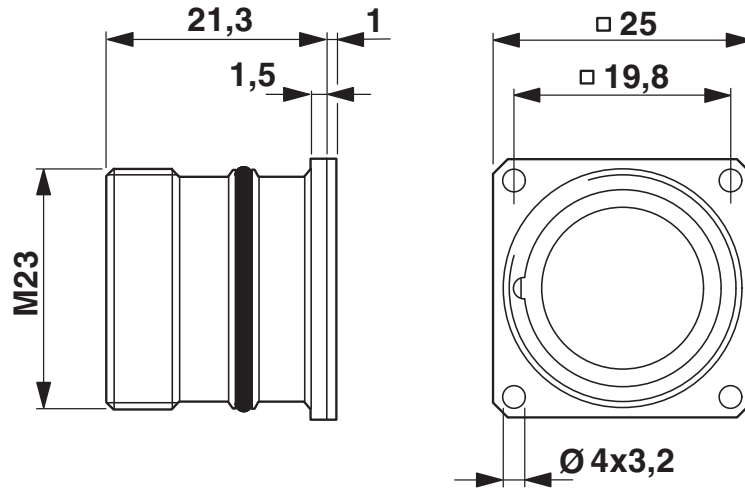

Dimensional drawing

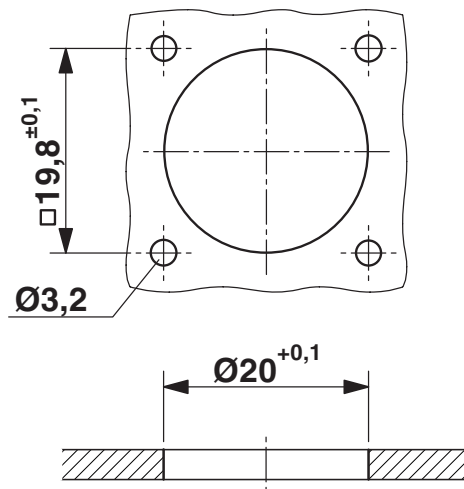

### Classifications

eCl@ss

eCl@ss 4.0	272607xx
eCl@ss 4.1	27260701
eCl@ss 5.0	27260701
eCl@ss 5.1	27260700
eCl@ss 6.0	27279200
eCl@ss 7.0	27440103
eCl@ss 9.0	27440102

## Device connector, front mounting - RC-1RP1N122300 - 1603027

### Classifications

#### ETIM

ETIM 3.0	EC001121
ETIM 4.0	EC001121
ETIM 6.0	EC001121

#### UNSPSC

UNSPSC 6.01	43172015
UNSPSC 7.0901	43201404
UNSPSC 11	43172015
UNSPSC 12.01	43201404
UNSPSC 13.2	39121413
UNSPSC 19.0	39121413

Phoenix Contact 2022 © - all rights reserved  
<http://www.phoenixcontact.com>

PHOENIX CONTACT GmbH & Co. KG  
Flachsmarktstr. 8  
32825 Blomberg  
Germany  
Tel. +49 5235 300  
Fax +49 5235 3 41200  
<http://www.phoenixcontact.com>