



050-130

PRODUCT BRIEF

Line Replaceable Unit (LRU) Copper to Fiber Media Converter,
Single or Dual Channel, Flange Mount
10/100/1000BASE-T to Fiber Optic Ethernet
(1000BASE-SX, 1000 BASE-LX10 or 100BASE-FX) 28VDC (DO-160
Audio Conducted Susceptibility Cat Z),
Lightning Strike (DO-160 level 3 waveform 3/3)
M38999 (ARINC801), M38999 (Quadrax), M38999 (Power)

REV	DESCRIPTION	DATE	APPROVED
1	Preliminary	01/18/2016	MF/MT
2	Add ECCN	05/24/2016	RAS
3	Add Flow Control Option	04/05/2017	RAS/GC
4	Update Quadrax Mating Connector PN	08/21/2018	GC
5	Add UID Marking. Add FO Inspection/Cleaning Tools. Correct the PRBS value. Update J2 pins' functions	03/13/2019	YA/RAS/TA

BF16U2-4518

THIS COPYRIGHTED DOCUMENT IS THE PROPERTY OF GLENAIR, INC. AND IS FURNISHED ON THE CONDITION THAT IT IS NOT TO BE DISCLOSED, REPRODUCED IN WHOLE OR IN PART, OR USED TO SOLICIT QUOTATIONS FROM COMPETITIVE SOURCES, OR USED FOR MANUFACTURE BY ANYONE OTHER THAN GLENAIR, INC. WITHOUT WRITTEN PERMISSION FROM GLENAIR, INC. THE INFORMATION HEREIN HAS BEEN DEVELOPED AT GLENAIR'S EXPENSE AND MAY BE USED FOR ENGINEERING EVALUATION AND INCORPORATION INTO TECHNICAL SPECIFICATIONS AND OTHER DOCUMENTS WHICH SPECIFY PROCUREMENT OF PRODUCTS FROM GLENAIR, INC.

050-130 PRODUCT BRIEF

Line Replaceable Unit (LRU) Media Converter, Flange Mount
10/100/1000BASE-T to Fiber Optic Ethernet (SX, LX10 or FX)



10/100/1000BASE-T to 1000BASE-SX or 1000BASE-LX10

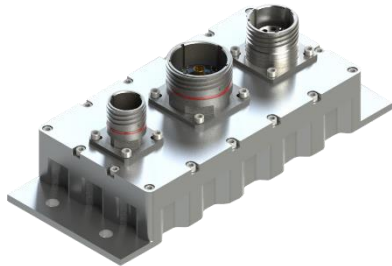

The Glenair 050-130 Flange Mount Copper to Fiber Media Converter can be configured as either Single Channel or Dual Channel and can convert 10/100/1000BASE-T to 1000BASE-SX, 1000BASE-LX or 100BASE-FX protocols. It is designed for harsh environments and incorporates electronics in an environmentally sealed enclosure that incorporates three environmental M38999 connectors. The power supply is designed to accept a wide DC input voltage range, 18V to 36V and dirty 28V power as defined in DO-160. Power is supplied through a 38999 with standard #22D contacts. Signal I/O passes through a 38999 with a combination of Quadrax and #22D contacts and Fiber Optics passes through a 38999 using ARINC 801 contacts which can be configured to support either single mode or multi-mode fiber applications.

KEY FEATURES/BENEFITS

- 1310nm FP Lasers for 1000BASE-LX10
- InGaAs PIN PD for 1000BASE-LX10
- 850nm Lasers for 1000BASE-SX
- GaAs PIN PD for 1000BASE-SX
- 1300nm LED for 100BASE-FX
- PIN PD for 100BASE-FX
- Wide Input Voltage Range: 18-36V
- Electrical Interface compliant with IEEE 802.3 (10/100/1000BASE-T)
- Optical Interface compliant with IEEE 802.3 (1000BASE-LX10/-SX, 100BASE-FX)
- DO-160 – Compliant to Lightning Strike Category A3J3XX & Voltage Spike Category A
- DO-160 – Compliant to Audio Frequency Conducted Susceptibility input, Category Z
- Option to implement Flow Control

- Ethernet MDI/MDIX automatic crossover
- Magnetics on the electrical signal input side to support 10/100/1000BASE-T operation over 100m Cat 5E
- IP67 in mated condition
- M38999 Quadrax & pin for Signal, BIT and service port
- M38999 Power
- M38999 ARINC 801 for Fiber Optic
- Flange Mount
- Single or Dual Channel Configurations

OPTIONAL FEATURES

- Built In Test Console Port accessible via USB2.0
- Built in Test Console Port accessible via UART-RS422

APPLICATIONS

- Harsh Environment such as: Airborne, Tactical, Railway, Industrial, Oil and Gas and Shipboard applications

How To Order

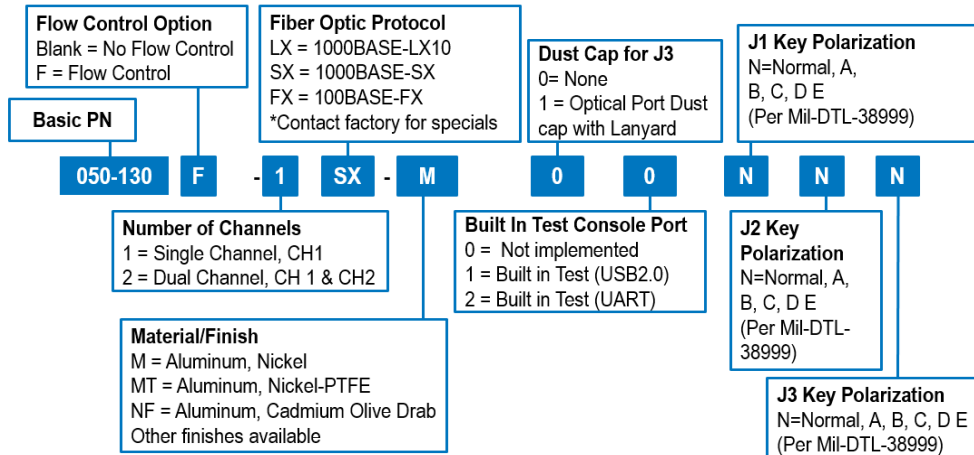

050-130 PRODUCT BRIEF

Line Replaceable Unit (LRU) Media Converter, Flange Mount
10/100/1000BASE-T to Fiber Optic Ethernet (SX, LX10 or FX)



Functional Block Diagram

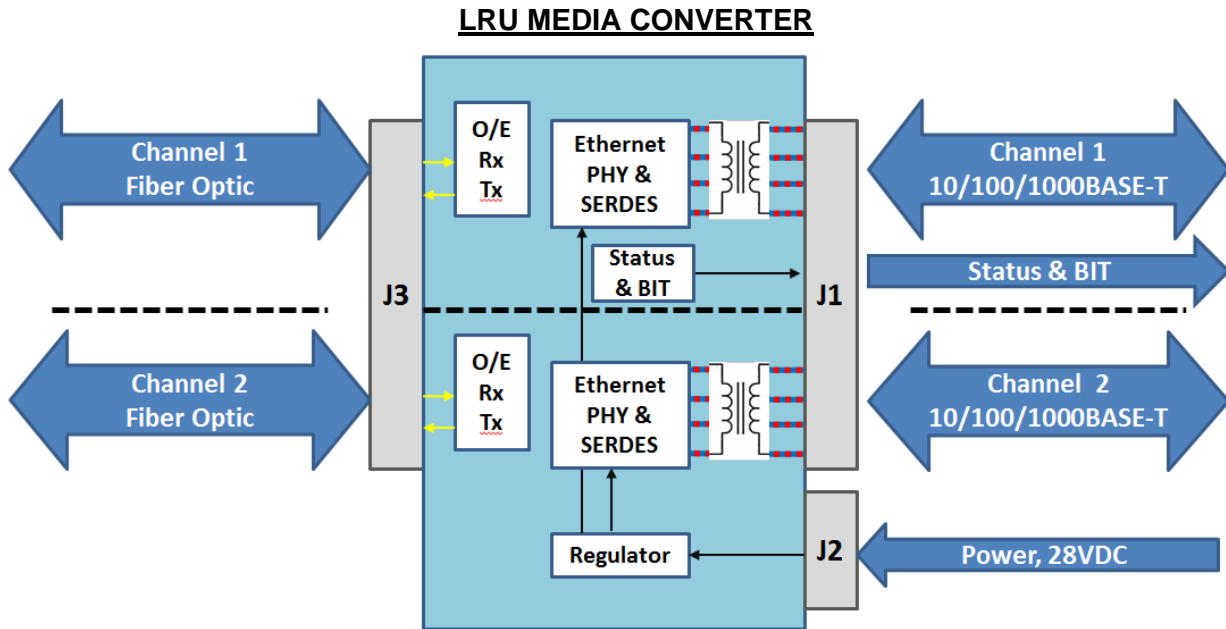

Note: Fiber Optic Channels can be 1000BASE-LX, 1000BASE-SX, 100BASE-FX

Other Fiber Optic connections possible – Contact Glenair

Flow Control

Ethernet flow control is a mechanism for temporarily stopping the transmission of data on Ethernet computer networks. If data flow between the two devices connected to the media converter will vary in rate, it is up to the end user to ensure their higher speed devices are throttled correctly to ensure loss of data does not occur over time. Flow control can be enabled at the factory if so desired. Contact the factory for more details.

050-130 PRODUCT BRIEF

Line Replaceable Unit (LRU) Media Converter, Flange Mount
10/100/1000BASE-T to Fiber Optic Ethernet (SX, LX10 or FX)

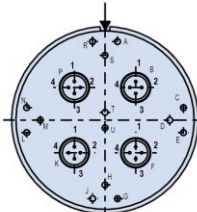
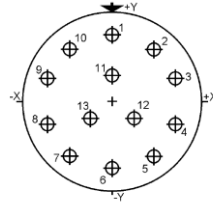
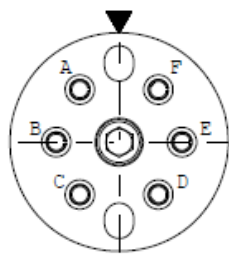

Connectors

NAME	Insert Arrangement	Function	Media Converter	Mating PLUG Connector
J1		Electrical Signal, Status and Built In Test (BIT)	D38999 Series III type, 19Q-18 14X SIZE 22D Pins 4X SIZE 8 QUADRAX Pins (AS39029/119)	Generic PN D38999/26#F18SN type with Quadrax polarization **Glenair PN 257-606##G6-19Q-18BN
J2		Power	D38999 Series III type, 11-35 13X SIZE 22D Pins	Generic PN D38999/26#B35SN Glenair PN 233-105-G6##11-35SN
J3	 ARR. 15-6 SHELL SIZE 15	Fiber Optic Signal	D38999 Series III Insert Arrangement per ARINC 801 <u>CONTACTS</u> ARINC 801 LX CONFIGURATION: SX CONFIGURATION: Contacts: Radial pn F725003419 or equivalent	Glenair PN 180-159##06-15-6N-R (D38999 Style Plug, ARINC 801 15-6 arrangement) <u>CONTACTS:</u> LX10 CONFIGURATION Glenair PN 181-076-P-126S 126.0 micron, pull proof design, SMF SX or FX CONFIGURATION Glenair PN 181-076-P-126 126.0 micron, pull proof design, MMF

Note: # = Environmental Class (Material/Finish)

**Connector is supplied less contacts. Optional mode code 557 can be added to the end of the part number to include contacts (including spares), insertion/removal tool, and sealing plugs. Contact manufacturer for additional options.

050-130 PRODUCT BRIEF

Line Replaceable Unit (LRU) Media Converter, Flange Mount
10/100/1000BASE-T to Fiber Optic Ethernet (SX, LX10 or FX)



Built In Test (BIT) Functionality – USB 2.0

This media converter can be offered with built in test functionality accessible through a Console Port via Universal Serial Bus 2.0 (USB 2.0) or via RS422 UART (TXD) or both options can be made available. Functional block diagram for this is shown below.

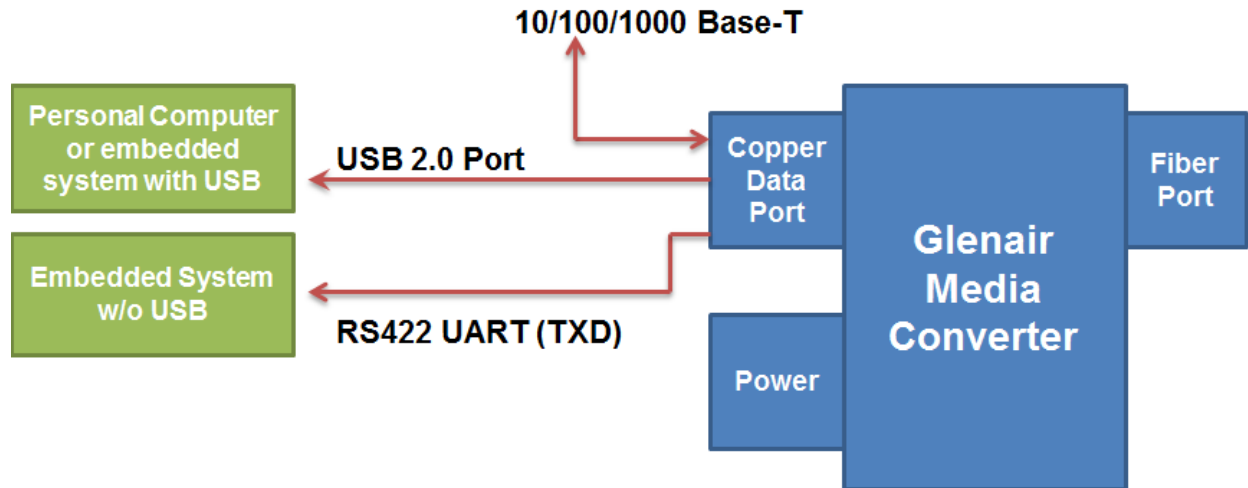

Universal Serial Bus (2.0) BIT

- Presents itself as a "Virtual" Communications Port
- Compatible with Microsoft Windows, Mac, and Linux OS's.
- On the computer side, open any terminal application (PuTTY, HyperTERM, TeraTERM, etc.) to communicate with the media converter hardware.
- Simple "Human Readable" status messages.

ALARM STATUS MESSAGES

Unit Identification Information

- Unit Serial Number
- Unit Product Code

Fiber Side Alarm/Status

- Temperature
- Transmitter TX Fault
- Transmitter Disable Status
- Receiver loss of signal (LOS) or signal Detect (SD) Status

Copper Side Status

- Link Status (Up or Down)

050-130 PRODUCT BRIEF

Line Replaceable Unit (LRU) Media Converter, Flange Mount
10/100/1000BASE-T to Fiber Optic Ethernet (SX, LX10 or FX)



TYPICAL CONSOLE PORT WINDOW (PuTTY)

```
COM1 - PuTTY
*****
Glenair *
Media Converter Service Port *
*****
Unit Identification Information
*****
Product Code: 050-130-1SX
Unit Serial Number: 0145
Firmware Revision: 1.2.0
Product Description: 10/100/1000 Mbps Ethernet Copper to Fiber Media Converter

*****
Unit Status
*****
Temperature: 45 degrees C
Power Supply Status: Good
RX Loss of Signal, CH1: False
Transceiver Disable, CH1: False
Transceiver, TX Fault, CH1: False
Copper-Side Link Status, CH1: Up
Fiber-Side Link Status, CH1: Up
```

050-130 PRODUCT BRIEF

Line Replaceable Unit (LRU) Media Converter, Flange Mount
10/100/1000BASE-T to Fiber Optic Ethernet (SX, LX10 or FX)



Built In Test (BIT) Functionality – UART

This media converter can be offered with built in test functionality accessible via an RS-422 Port. The UART Bit message is a 10 bit message with an update rate of 1 Hz. The message format can be seen below.

ALARM STATUS MESSAGES

- Fiber Link Status (Up or Down)
- Copper Link Status (Up or Down)
- Power Supply Status (In Range, or Fault)

Ethernet Media Converter Status Message Format

Standard UART-Type Format (Start and Stop Bits, 8 Data bits, no parity)

Data Rate = 9600 baud, RS422 Output, Message Repetition Rate = 1 Sec

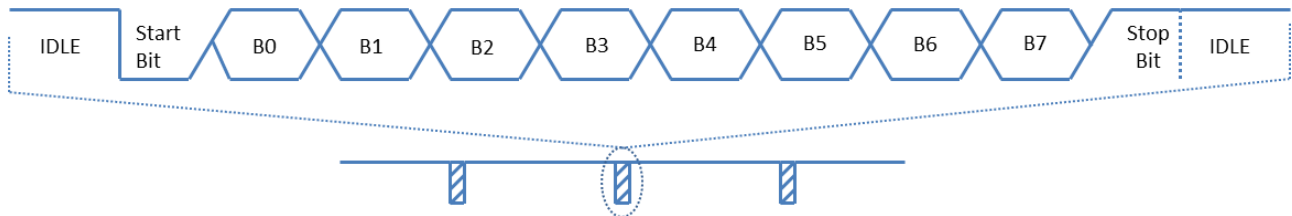

SERIAL STATUS MESSAGE BIT MAPPING

Bit	Description
0	Channel 1 Fiber Optic TX Fault (1 = Fault, 0 = No Fault)
1	Channel 1 Ethernet copper Link UP (1 = Link Up, 0 = Link Down)
2	Channel 1 Power Supply Voltage "In Range" Fault (1 = Fault, 0 = No Fault)
3	Not used
4	Channel 2 Fiber Optic TX Fault (1 = Fault, 0 = No Fault)
5	Channel 2 Ethernet copper Link UP (1 = Link Up, 0 = Link Down)
6	Channel 2 Power Supply Voltage "In Range" Fault (1 = Fault, 0 = No Fault)
7	Not Used

050-130 PRODUCT BRIEF

Line Replaceable Unit (LRU) Media Converter, Flange Mount
10/100/1000BASE-T to Fiber Optic Ethernet (SX, LX10 or FX)



Ratings and Specifications – LX10 VERSION

ABSOLUTE MAXIMUM RATINGS

Parameter	Symbol	Min	Typ	Max	Units	Notes
Storage Temperature	T _s	-55		+100	°C	
Supply Voltage	V _{cc}	-0.5		40	V	

OPERATING CONDITIONS

Parameter	Symbol	Min	Typ	Max	Units	Notes
Operating Temperature	T _{op}	-40		+85	°C	
Supply Voltage	V _{cc}	18	28	36	V	
Supply Current	I _{cc}		100	150	mA	@28VDC PER CHANNEL
Power Supply Noise (Peak-Peak)	V _{cc_ripple}			**	V	** Per DO-160G, Table 18-3, Category Z for 28VDC

OPTICAL CHARACTERISTICS – TRANSMITTER

Parameter	Symbol	Min	Typ	Max	Units	Notes
Optical Output Power	P _{OUT}	-8.5	-4	-3	dBm	1310nm Fabry-Perot
Optical Wavelength	λ _{OUT}	1270	1310	1355	nm	
Spectral Width	Δλ			2.5	nm	

OPTICAL CHARACTERISTICS – RECEIVER

Parameter	Symbol	Min	Typ	Max	Units	Notes
Optical Sensitivity (Input Power Range)	P _{IN_OP}	-20		0	dBm	
Min. Sensitivity, BER 10 ⁻¹² , PRBS 7	P _{IN_MIN}		-22	-20	dBm	PIN PD, LX10 source
Overload, BER 10 ⁻¹² , PRBS 7	P _{IN_MAX}	0			dBm	
Optical Wavelength	λ _{IN}	1100	1310	1590	nm	

ETHERNET COMPLIANCE

Parameter	Medium Type	Distance	Notes
Gigabit Ethernet, IEEE 802.3ab, 1000BASE-T	TIA/EIA-568-B Cat 5E	100m	
Gigabit Ethernet, IEEE 802.3z, 1000BASE-LX10	Single Mode Fiber (9/125μm)	10km	

050-130 PRODUCT BRIEF

**Line Replaceable Unit (LRU) Media Converter, Flange Mount
10/100/1000BASE-T to Fiber Optic Ethernet (SX, LX10 or FX)**



Ratings and Specifications – SX VERSION

ABSOLUTE MAXIMUM RATINGS

Parameter	Symbol	Min	Typ	Max	Units	Notes
Storage Temperature	T _s	-55		+100	°C	
Supply Voltage	V _{cc}	-0.5		40	V	

OPERATING CONDITIONS

Parameter	Symbol	Min	Typ	Max	Units	Notes
Operating Temperature	T _{op}	-40		+85	°C	
Supply Voltage	V _{cc}	18	28	36	V	
Supply Current	I _{cc}		100	150	mA	@28VDC PER CHANNEL
Power Supply Noise (Peak-Peak)	V _{cc_ripple}			**	V	** Per DO-160G, Table 18-3, Category Z for 28VDC

OPTICAL CHARACTERISTICS – TRANSMITTER

Parameter	Symbol	Min	Typ	Max	Units	Notes
Optical Output Power	P _{OUT}	-9.5		-1	dBm	VCSEL, 62.5/125µm MM
Optical Wavelength	λ _{OUT}	830	850	860	nm	
Spectral Width	Δλ			0.85	nm	

OPTICAL CHARACTERISTICS - RECEIVER

Parameter	Symbol	Min	Typ	Max	Units	Notes
Optical Sensitivity (Input Power Range)	P _{IN_OP}	-17		-1	dBm	
Min. Sensitivity, BER 10 ⁻¹² , PRBS 7	P _{IN_MIN}		-19	-17	dBm	PIN PD
Overload, BER 10 ⁻¹² , PRBS 7	P _{IN_MAX}	-1	0		dBm	
Optical Wavelength	λ _{IN}	770	850	860	nm	

ETHERNET COMPLIANCE

Parameter	Medium Type	Distance	Notes
Gigabit Ethernet, IEEE 802.3ab, 1000BASE-T	TIA/EIA-568-B Cat 5E	100m	
Gigabit Ethernet, IEEE 802.3z, 1000BASE-SX	OM3 MMF (50/125µm) OM1 MMF (62.5/125µm)	550m 275m	850nm VCSEL

050-130 PRODUCT BRIEF

**Line Replaceable Unit (LRU) Media Converter, Flange Mount
10/100/1000BASE-T to Fiber Optic Ethernet (SX, LX10 or FX)**



Ratings and Specifications – FX VERSION

ABSOLUTE MAXIMUM RATINGS

Parameter	Symbol	Min	Typ	Max	Units	Notes
Storage Temperature	T _s	-55		+100	°C	
Supply Voltage	V _{cc}	-0.5		40	V	

OPERATING CONDITIONS

Parameter	Symbol	Min	Typ	Max	Units	Notes
Operating Temperature	T _{op}	-40		+85	°C	
Supply Voltage	V _{cc}	18	28	36	V	
Supply Current	I _{cc}		100	150	mA	@28VDC, PER CHANNEL
Power Supply Noise (Peak-Peak)	V _{cc_ripple}			**	V	** Per DO-160G, Table 18-3, Category Z for 28VDC

OPTICAL CHARACTERISTICS – TRANSMITTER

Parameter	Symbol	Min	Typ	Max	Units	Notes
Optical Output Power	P _{OUT}	-19		-14	dBm	1300nm LED (IEC 9314-3)
Optical Wavelength	λ _{OUT}	1270	1310	1380	nm	
Spectral Width	Δλ		150		nm	

OPTICAL CHARACTERISTICS - RECEIVER

Parameter	Symbol	Min	Typ	Max	Units	Notes
Sensitivity, BER 10 ⁻¹⁰ , PRBS 7	P _{IN}			-32	dBm	PIN PD
Overload, BER 10 ⁻¹⁰ , PRBS 7	P _{IN}	-14			dBm	
Optical Wavelength	λ _{IN}	1270	1310	1380	nm	

ETHERNET COMPLIANCE

Parameter	Medium Type	Distance	Notes
Fast Ethernet, IEEE 802.3u, 100BASE-T	TIA/EIA-568-B Cat 5E	100m	
Fast Ethernet, IEEE 802.3u, 100BASE-FX, IEC 9314-3	MMF (50/125μm) & (62.5/125μm)	2km	

050-130 PRODUCT BRIEF

Line Replaceable Unit (LRU) Media Converter, Flange Mount
10/100/1000BASE-T to Fiber Optic Ethernet (SX, LX10 or FX)



Ratings and Specifications - (continued)

COMPLIANCE SPECIFICATIONS

CHARACTERISTIC	Standard	Condition	Notes
Mechanical Shock	MIL-STD-810	40g	6-9 ms
Mechanical Vibration	MIL-STD-810	30g rms	Per Addendum
Power Input	DO-160G, Section 16	28VDC, Category Z	No damage, Normal Operation (BER free) before and after test
Voltage Spike	DO-160G, Section 17	Category A	No damage, Normal Operation (BER free) before and after test
Power supply, Audio Frequency Conducted Susceptibility	DO-160G, Section 18	Category Z	Normal Operation (BER free) in the presence of "Dirty Power"
Induced Signal Susceptibility	DO-160G, Section 19	Category Z	No damage, Normal Operation (BER free) before and after test
RF Frequency Susceptibility Conducted Susceptibility	DO-160G Section 20.4	Category R	
RF Frequency Susceptibility Radiated Susceptibility	DO-160G Section 20.5	Category R	
Emission of Radio Frequency Energy Conducted Emissions	DO-160G, Section 21.4	Category M	
Emission of Radio Frequency Energy Radiated Emissions	DO-160G, Section 21.3	Category M	
Lightning Strike	DO-160G, Section 22	Category A3J3XX	No damage, Operate error free before and after application of the pin injection tests. Will operate error free during shielded cable bundle injection tests
ESD	IEC 61000-4-2		Min 8KV (contact) Min 15KV (Air)
Mating Durability	MIL-DTL--38999/20	500 Cycles	
Flame Resistance	EIA364-104		30 seconds
Damp Heat	EIA364-321		240 hours
Eye Safety	CDRH and IEC-825	Class 1 Laser Product	

050-130 PRODUCT BRIEF

**Line Replaceable Unit (LRU) Media Converter, Flange Mount
10/100/1000BASE-T to Fiber Optic Ethernet (SX, LX10 or FX)**



Ratings and Specifications - (continued)

Material/Finish

Item	Material/Finish
Housing & Connector Shell	Aluminum
Plating Finish: M	Nickel
Plating Finish: MT	Nickel PTFE
Plating Finish: NF	Olive Drab Cadmium
Contacts	Copper alloy, 50 µInch gold plated
D38999 Inserts	Thermoplastics
Interfacial Seals, 38999 only	Elastomer, Fluorosilicon
Optical Ferrules & Sleeves	Zirconia, Ceramic
Insulators	Liquid crystal polymer (LCP)
Contact retention clip	Beryllium copper alloy
Seal, O-rings	Fluorosilicone or EPDM
Seal	Fluorosilicone or EPDM
Spring	Nickel-plated beryllium copper
PC tail contacts	Copper alloy/gold plated
PCB flex	FR4 & Polyimide
Solder type: Connector PC Tails to PCBA	Sn63Pb37 or Sn60Pb40
Encapsulant	HYSOL EE4215
Solder type	RoHS compliant Sn95/Sb5 (232°C melting temp) & RoHS compliant Sn96.5/Ag3.0/Cu0.5 (217° melting)

050-130 PRODUCT BRIEF

Line Replaceable Unit (LRU) Media Converter, Flange Mount
10/100/1000BASE-T to Fiber Optic Ethernet (SX, LX10 or FX)



OUTLINE DRAWING

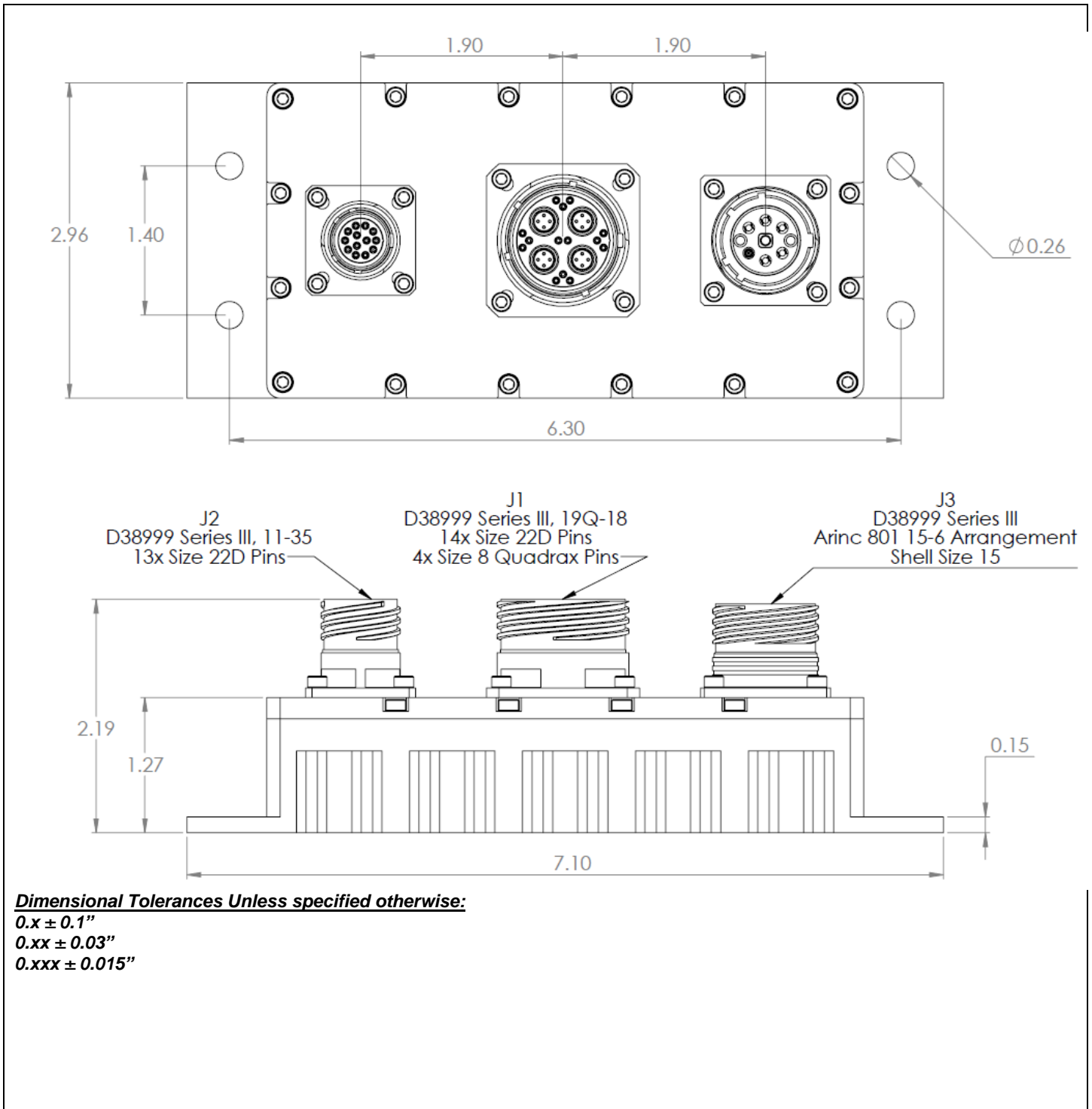

Dimensional Tolerances Unless specified otherwise:

0.x ± 0.1"

0.xx ± 0.03"

0.xxx ± 0.015"

050-130 PRODUCT BRIEF

Line Replaceable Unit (LRU) Media Converter, Flange Mount
10/100/1000BASE-T to Fiber Optic Ethernet (SX, LX10 or FX)



Marking:

Assembly is identified with a label containing Manufacturer's Name, Cage Code, Part Number, Date Code and Serial Number. The label also includes a UID to report the part number and the serial part number for tracing purposes. The UID is a Construct Number 2 MIL-STD-130N Data Matrix Symbol using ECC 200 encoding/decoding format.

Weight:

Description	Weight	Comments
050-130-1 Single Channel Media Converter	1.42 lbs Max.	exclude dust caps
050-130-2 Dual Channel Media Converter	1.45 lbs Max.	

Connectors will be covered with protective caps at time of shipment

Please contact Glenair for other configurations

MOUNTING HOLE LOCATIONS

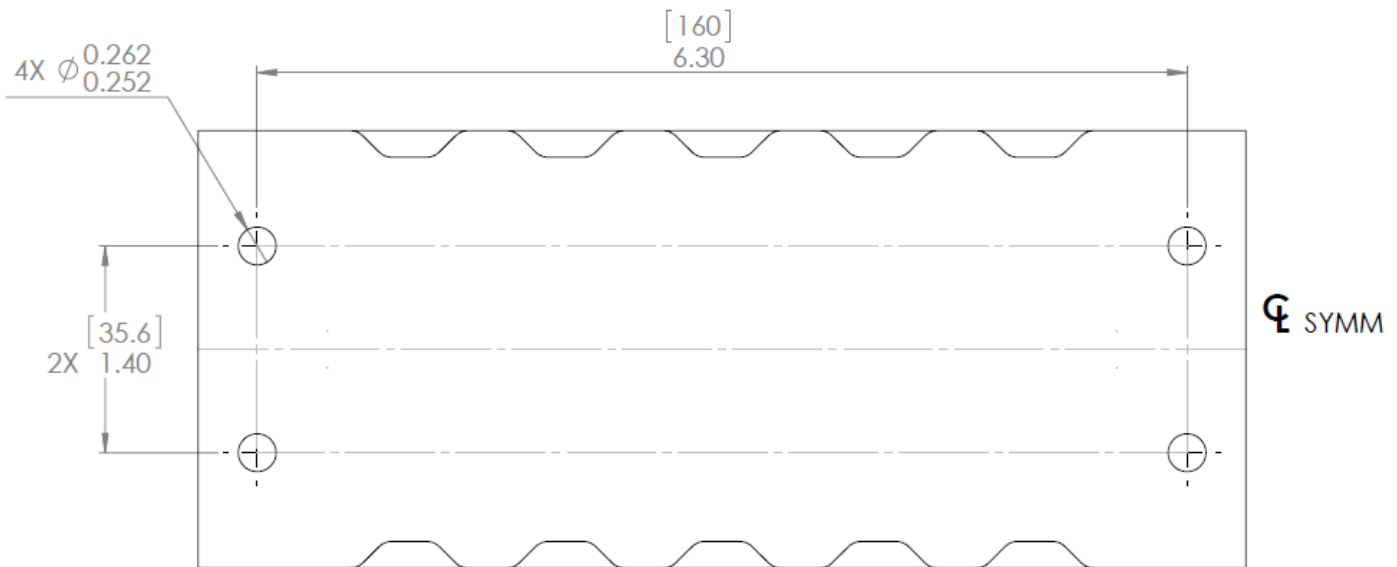

RECOMMENDED MOUNTING HOLES FOR BASEPLATE

¼" HARWARE REQUIRED FOR MOUNTING

Dimensional Tolerances Unless specified otherwise:

0.x ± 0.1" 0.xx ± 0.03" 0.xxx ± 0.015"

050-130 PRODUCT BRIEF

Line Replaceable Unit (LRU) Media Converter, Flange Mount
10/100/1000BASE-T to Fiber Optic Ethernet (SX, LX10 or FX)



Input/output Definition

050-130 PRODUCT BRIEF

Line Replaceable Unit (LRU) Media Converter, Flange Mount
10/100/1000BASE-T to Fiber Optic Ethernet (SX, LX10 or FX)



Recommended Inspection & Cleaning Tools/Kits

The following recommendations are suggested for this product:

- GBS-1001 Inspection Kit which includes GIT-003 tip for ARINC 801 fiber contacts.
- GCLT-H200 or GCLT-HA125 cleaning tool for ARINC 801 system.

GBS1001 Inspection Probe with USB Adapter and Fiber Chek 2 Software



How To Order

GBS1001

Basic Part Number Includes:

- *Inspection probe with USB adapter*
- *Fiber Chek 2 Software*

Comes with

(installed on the probe):

GIT-003 Universal 1.25mm patch cord

The GBS1001 is the only inspection probe today with a high resolution, all digital sensor and USB2 video stream which delivers high-resolution uncompressed images directly to your personal computer.

GBS1001 Specifications

Weight	.11 Kg / .25 lb
Resolution	Better than 1.5 Microns
Cable	Integrated USB 2.0 coil cable 2.5' relaxed, 10.5' fully extended
Certification	CE
Warranty	1 year

Fiber Chek Software

Fiber Optic Analysis Program

Fiber Chek is an integrated hardware/software package engineered with the single purpose of critically and consistently grading fiber end-faces. Works hand in hand with the Quick Capture Analog Probe for visual inspection, taking pictures and testing fibers.

- Automatic debris and defect detection, including fine scratches
- Measures epoxy ring for out-of-tolerance conditions
- Inspection results, including image data, can be printed or archived
- Utilizes industry standards or user defined threshold settings

050-130 PRODUCT BRIEF

Line Replaceable Unit (LRU) Media Converter, Flange Mount
10/100/1000BASE-T to Fiber Optic Ethernet (SX, LX10 or FX)



Recommended Inspection & Cleaning Tools/Kits – (Continued)

Dry action cleaning tool for ARINC 801 systems

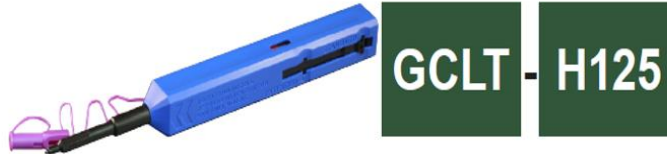

Dry action cleaning tool for ARINC 801 test adapters



- A simple push motion engages tool
- Audible click when tool is fully engaged
- Durable — over 525 engagements per tool
- Crush resistant to over 250N
- Impact resistant to survive drops over 1.5M