

μ PD71051-Compliant Serial Control Unit Gate Array

Following the phase-out of its popular μ PD71051 standard serial control unit (USART), NEC Electronics is now offering the μ PD65881GB-P02 serial control unit, a functional and low-cost substitute for the μ PD71051.

To verify the applicability of the μ PD65881GB-P02 gate array as a replacement for the μ PD71051, you must first test an equivalent prototype in the system being developed. If the in-system test is deemed successful, then you may proceed to purchase mass production versions of the product.

DESCRIPTION

Internal block functions and commands are the same as those of the μ PD71051. Differences between the two products are listed below. Before adopting this product, carefully read the disclaimer below and the caution in section 3 (CAUTIONS WHEN CONSIDERING ADOPTION OF THIS PRODUCT).

The μ PD65881GB-P02 integrates an NA55A IP macro in a CMOS-N5 gate array that can be used as a peripheral I/O device to transmit serial data synchronously, asynchronously, or bi-synchronously.

The USART receives serial data streams and converts them into parallel data characters for the CPU. While receiving serial data, the USART can also accept parallel data from the CPU, convert it to serial data, and then transmit it. The USART signals the CPU when it has received or transmitted a character and requires service. The CPU may read complete USART status data at any time.

FEATURES

- Synchronous operation
- One or two synchronous characters
- Internal/external synchronization
- Automatic SYNC character insertion
- Asynchronous operation
- Clock rate (baud rate): $\times 1$, $\times 16$, or $\times 64$
 - Send stop bits: 1, 1.5, or 2 bits
 - Break transmission
 - Automatic break detection
 - Valid start bit detection
- Baud rate: DC ~ 660 Kb/s at $\times 1$ clock
- Full-duplex, double-buffered transmitter/receiver
- Error detection: parity, overrun, and framing
- Five- to eight-bit characters
- Low-power standby mode
- Compatible with standard microcontrollers
- Functionally equivalent to (except in standby mode) and can replace the μ PD8251AF
- CMOS process technology
- Single +5V $\pm 10\%$ power supply
- Industrial temperature range (Ambient): -40 to 85°C
- 44-pin QFP package
- RoHS-compliant

The information in this document is subject to change without notice. Before using this document, please confirm that this is the latest version.

Not all products and/or types are available in every country. Please check with an NEC Electronics sales representative for availability and additional information.

Disclaimer

- This product is not functionally equivalent to any similar non-NEC Electronics product. NEC Electronics shall assume no responsibility for any loss or damage incurred by customers or third parties resulting from the replacement of products similar to, but other than, the μPD71051GB-10-3B4.
- NEC Electronics shall assume no responsibility for any loss or damage incurred by customers or third parties resulting from the use of this product outside the conditions described in the absolute maximum ratings, recommended operation range, and quality grades.

COMPARISON OF μPD65881GB-P02 AND μPD71051

| Feature | This Product | μPD71051 | Reference |
|--|--|---|--|
| Part number (mark) | μPD65881GB-P02-3BS-A (658N51) | μPD71051GB-10-3B4 (standard NEC Electronics mark) | - |
| Package type | Only 44-pin QFP | QFP, DIP, SOP, PLCC (QFJ) | - |
| Package shape (comparison of 44-pin QFP) | The body size and package width are the same, but the pin lengths and pin bending method are different. | | 4. PACKAGE DRAWING |
| Function of pin 39 | IC (connection with external pin prohibited) | NC | 1. PIN LAYOUT |
| Lead-free support | Yes | No | ORDERING INFORMATION |
| Recommended soldering conditions | IR60-207-3, partial heating | IR35-00-3, VP15-00-3, WS60-00-1, partial heating | 5. RECOMMENDED SOLDERING CONDITIONS |
| Absolute maximum ratings | | | 2. ELECTRICAL SPECIFICATIONS |
| Power supply voltage | -0.5 to +6.0 (V) | -0.5 to +7.0 (V) | |
| Input voltage | -0.5 to +6.0 (V) | -0.5 to V _{DD} +0.3 (V) | |
| Output voltage | -0.5 to +6.0 (V) | -0.5 to V _{DD} +0.3 (V) | |
| Recommended operating range | T _A = -40 to +85°C, V _{DD} = 5 V±10% This product does not guarantee operation at less than 4.5 V. | | |
| DC characteristics | Partially different | | |
| AC characteristics | This product has the following restrictions on load capacitance. D7 to D0: 100 pF or less TXDATA, SYNC/BRK, RXRDY, TXEMP, TXRDY: 40 pF or less | | |

ORDERING INFORMATION

| Part Number | Package |
|----------------------|---------------------------------|
| μPD65881GB-P02-3BS-A | 44-pin plastic QFP (10 x 10 mm) |

Remark Products with -A at the end of the part number are lead-free products.

QUALITY GRADES

"Standard"

This product is intended to be used for applications such as computers, office equipment, communications equipment, test and measurement equipment, and home electronic appliances. It therefore cannot be used for the following applications.

Applications requiring special or specific grades, such as transportation equipment (automobiles, trains, ships, etc.), traffic control systems, medical equipment, aircraft equipment, and aerospace equipment.

Remark For details of quality grades, refer to **Quality Grades on NEC Semiconductor Devices (document number: C11531E)**.

BLOCK DIAGRAM (μPD71051)

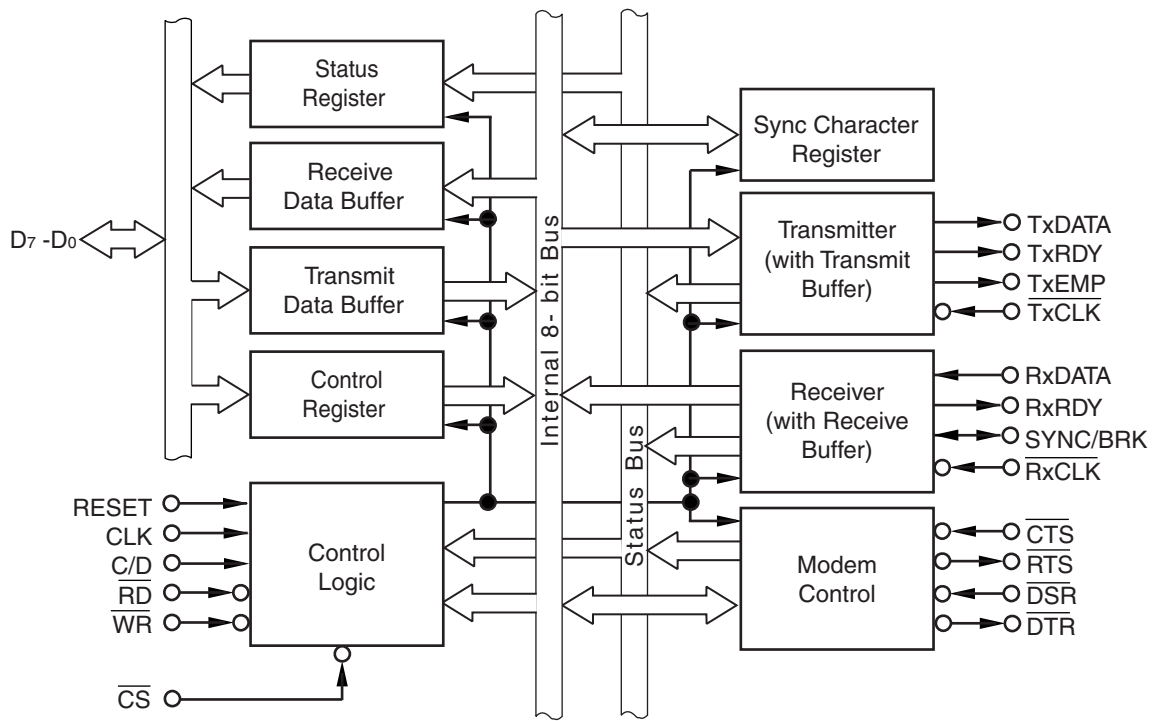

1. PIN LAYOUT

For a description of pin functions, refer to the μ PD71051 Data Sheet (document number: IC-6494) (Japanese version).

| Pin No. | I/O | Pin Name | Name of Pin on μ PD71051 | Pin No. | I/O | Pin Name | Name of Pin on μ PD71051 |
|---------|-----|--------------------------|------------------------------|---------|-----|---------------------------------------|------------------------------|
| 1 | - | NC | ← | 23 | - | NC | ← |
| 2 | - | NC | ← | 24 | - | NC | ← |
| 3 | O | TXD | TxDATA | 25 | I/O | D4 | ← |
| 4 | I | CLK | ← | 26 | I/O | D5 | ← |
| 5 | I | RESET | ← | 27 | I/O | D6 | ← |
| 6 | - | NC | ← | 28 | - | NC | ← |
| 7 | I | DSRB | $\overline{\text{DSR}}$ | 29 | I/O | D7 | ← |
| 8 | O | RTSB | $\overline{\text{RTS}}$ | 30 | I | TXCLK | $\overline{\text{TxCLK}}$ |
| 9 | O | DTRB | $\overline{\text{DTR}}$ | 31 | I | WRB | $\overline{\text{WR}}$ |
| 10 | - | NC | ← | 32 | - | NC | ← |
| 11 | - | NC | ← | 33 | - | NC | ← |
| 12 | - | NC | ← | 34 | - | NC | ← |
| 13 | I | RXCLK | $\overline{\text{RxCLK}}$ | 35 | I | CSB | $\overline{\text{CS}}$ |
| 14 | - | V _{DD} | ← | 36 | I | CD | $\overline{\text{CD}}$ |
| 15 | I/O | D0 | ← | 37 | I | RDB | $\overline{\text{RD}}$ |
| 16 | I/O | D1 | ← | 38 | O | RXRDY | RxRDY |
| 17 | - | IC (GND) ^{Note} | IC | 39 | - | IC (V _{DD}) ^{Note} | NC |
| 18 | I/O | D2 | ← | 40 | O | TXRDY | TxRDY |
| 19 | I/O | D3 | ← | 41 | I/O | SYN_BRK | SYNC/BRK |
| 20 | I | RXD | RxDATA | 42 | I | CTSB | $\overline{\text{CTS}}$ |
| 21 | - | GND | ← | 43 | O | TXEMP | TxEMP |
| 22 | - | NC | ← | 44 | - | NC | ← |

Note This pin is connected to GND or V_{DD} in the chip. To enhance the power supply to handle noise, this pin can be connected to the power supply pin of the board to improve the noise resistance performance.

2. ELECTRICAL SPECIFICATIONS

This section describes only the differences with the μPD71051.

For electrical specifications other than those below, refer to the μPD71051 Data Sheet (document number: IC-6494).

Absolute Maximum Ratings

| Parameter | Symbol | Conditions | Ratings | Unit |
|----------------------|-----------------|------------|--------------|------|
| Power supply voltage | V _{DD} | | -0.5 to +6.0 | V |
| Input voltage | V _i | | -0.5 to +6.0 | V |
| Output voltage | V _o | | -0.5 to +6.0 | V |

Caution Product quality may suffer if the absolute maximum rating is exceeded even momentarily for any parameter. In other words, the absolute maximum ratings are values at which the product may begin to suffer degradation. Therefore the product must be used under conditions that ensure that the absolute maximum ratings are not exceeded.

Recommended Operating Range

This is the same as the μPD71051. This product does not guarantee operation at less than 4.5 V.

DC Characteristics (V_{DD} = 5 V±10%, T_A = -40 to +85°C)

| Parameter | Symbol | This Product | | | | μPD71051 | | | | Unit |
|----------------------|-----------------|---------------------------|----------------------|------|-----------------|------------------------------|---------------------|------|----------------------|------|
| | | Condition | Min. | Typ. | Max. | Condition | Min. | Typ. | Max. | |
| Input voltage, high | V _{IH} | | 2.29 | | V _{DD} | | 2.2 | | V _{DD} +0.3 | V |
| Input voltage, low | V _{IL} | | 0.00 | | 0.77 | | -0.5 | | 0.8 | V |
| Output voltage, high | V _{OH} | I _{OH} = 0 mA | V _{DD} -0.1 | | | I _{OH} = -400 μA | 0.7×V _{DD} | | | V |
| | | I _{OH} = 3 mA | V _{DD} -0.4 | | | | | | | |
| Output voltage, low | V _{OL} | I _{OL} = 3 mA | | | 0.4 | I _{OL} = 2.5 mA | | | 0.4 | V |
| Output current, low | I _{OL} | | 3.0 | | | | 2.5 | | | mA |

AC Characteristics

These are similar to the μPD71051 characteristics, except for the following restrictions on load capacitance. Operation outside the range of these restrictions is not guaranteed.

D7 to D0: 100 pF or less

TXDATA, SYNC/BRK, RXRDY, TXEMP, TXRDY: 40 pF or less

3. CAUTIONS WHEN CONSIDERING ADOPTION OF THIS PRODUCT

When considering the adoption of this product, note the following points.

(1) Functional check using product samples

Before adopting this product, make sure to request product samples from NEC Electronics to check the functions. Product samples are available free of charge.

When mounting this product onto different multiple printed circuit boards, extensively check the functions by changing the supply voltage to be supplied to the printed circuit boards as well as the temperature conditions for all printed circuit boards.

The standard number of product samples is five. When requesting product samples, provide the following information to your NEC Electronics sales representative.

Your company name, your name, product application, the period of starting adoption, the number of products to be adopted

(2) Submitting the Approval Sheet

When normal operation has been confirmed and the adoption has been decided, complete a copy of the Approval Sheet (Appendix of this document) and submit it to NEC Electronics.

(3) Shipment inspection

Shipment inspection is performed for this product using the μ PD71051GB-10-3B4 shipment test pattern. The DC characteristics satisfy the gate array shipment inspection.

(4) Order amount

Orders from a minimum of 100 units, and in units of 100 are accepted.

(5) Package, packing form

The dimensions are partially different from the μ PD71051GB-10-3B4. Refer to the package drawing and confirm that the product can actually be mounted. Dry pack tray packing is used for packing.

(6) Price

Contact your local NEC Electronics sales representative for pricing information.

(7) Obtaining the μ PD71051 Data Sheet^{Note}

The μ PD71051 (original product) Data Sheet is available from the NEC Electronics Web site (<http://www.necel.com/>) at

<http://www.necel.com/nedis/image/IC-6494D.pdf>

Note Please make this data sheet a standalone document. Do not refer customers to the data sheet for an obsolete device.

4. PACKAGE DRAWING

44-PIN PLASTIC QFP (10x10)

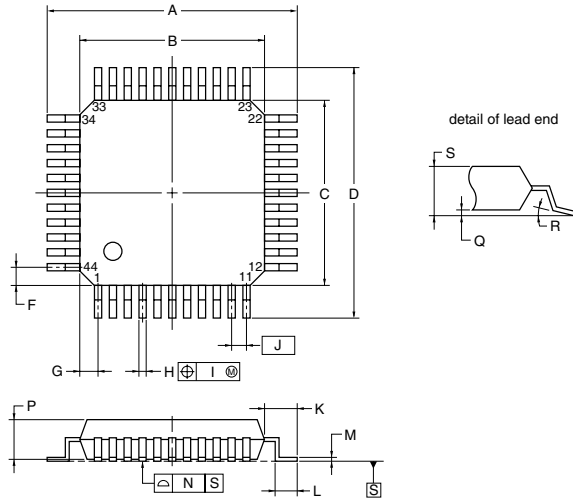

NOTE
Each lead centerline is located within 0.16 mm of its true position (T.P.) at maximum material condition.

| ITEM | MILLIMETERS |
|----------------|--|
| A | 13.2±0.2 |
| B | 10.0±0.2 |
| C | 10.0±0.2 |
| D | 13.2±0.2 |
| F | 1.0 |
| G | 1.0 |
| H | 0.37 ^{+0.08} _{-0.07} |
| I | 0.16 |
| J | 0.8 (T.P.) |
| K | 1.6±0.2 |
| L | 0.8±0.2 |
| M | 0.17 ^{+0.06} _{-0.05} |
| N | 0.10 |
| P | 2.7±0.1 |
| Q | 0.125±0.075 |
| R | 3 ⁺⁷ ₋₃ |
| S | 3.0 MAX. |
| S44GB-80-3BS-2 | |

5. RECOMMENDED SOLDERING CONDITIONS

These products should be soldered and mounted under the following recommended conditions.

For soldering methods and conditions other than those recommended below, please contact an NEC Electronicssales representative.

For technical information, see the following website.

Semiconductor Device Mount Manual (<http://www.necel.com/pkg/en/mount/index.html>)

| Soldering Method | Soldering Conditions | Recommended Condition Symbol |
|------------------|---|------------------------------|
| Infrared reflow | Package peak temperature: 260°C Time: 60 seconds max. (at 220°C or higher) Count: 3 times or less Exposure limit: 7 days ^{Note} (after that, prebake at 125°C for 20 to 72 hours) | IR60-207-3 |
| Partial heating | Pin temperature: 350°C max. Time: 3 seconds max. (per pin row) | - |

Note After opening the dry pack, store it at 25°C or less and 65% RH or less for the allowable storage period.

Caution Do not use different soldering methods together (except for partial heating).

APPENDIX APPROVAL SHEET

Copy this page and complete and confirm the required items.
 If you accept the conditions, sign and submit this sheet to NEC Electronics.

Approval Sheet

TO: NEC Electronics ()

| | |
|---|------------------|
| We have confirmed through sample evaluations that the device functions as stated in the specifications and agree to use the device in accordance with the boxes checked below in the "Confirmed Items" section. | |
| Company : | Date (yy/mm/dd): |
| Name: | Department: |
| Signature: | Title: |

Applications (Set)

| |
|--|
| |
|--|

Check the boxes below, to indicate confirmation of related matters.

| | | |
|--------------------------------|--|--|
| Device (Part-Number) | <input type="checkbox"/> μPD65881GB-P01-3BS-A (μPD71054 function compatible) <input type="checkbox"/> μPD65881GB-P02-3BS-A (μPD71051 function compatible) <input type="checkbox"/> μPD65881GB-P03-3BS-A (μPD71055 function compatible) | |
| NEC Electronics Counterpart | Office | |
| | Name | |
| Confirmed Items | Confirm the contents below and check the confirmed items. All items must be confirmed and checked. <input type="checkbox"/> 1. Differences from the original product (μPD71051/71054/71055) and notes for use of the function-compatible device(s) in the data sheet <input type="checkbox"/> 2. Proper operation in the actual application environment, using samples <input type="checkbox"/> 3. Necessity of re-evaluation before using in a new or different board or application set <input type="checkbox"/> 4. Necessity of using the board with at least four layers and a stable power supply. Conventionally ignored noise entering chips may be interpreted as being normal signals when the function-equivalent product is employed in a more advanced design process. | |

Additional Information required:

| | | |
|-------------------|------------|--|
| Demand/Forecast | | |
| M/P starting time | (yy/mm/dd) | |
| Monthly Run-Rate | (units) | |
| Comment | | |

NOTES FOR CMOS DEVICES

① VOLTAGE APPLICATION WAVEFORM AT INPUT PIN

Waveform distortion due to input noise or a reflected wave may cause malfunction. If the input of the CMOS device stays in the area between V_{IL} (MAX) and V_{IH} (MIN) due to noise, etc., the device may malfunction. Take care to prevent chattering noise from entering the device when the input level is fixed, and also in the transition period when the input level passes through the area between V_{IL} (MAX) and V_{IH} (MIN).

② HANDLING OF UNUSED INPUT PINS

Unconnected CMOS device inputs can be cause of malfunction. If an input pin is unconnected, it is possible that an internal input level may be generated due to noise, etc., causing malfunction. CMOS devices behave differently than Bipolar or NMOS devices. Input levels of CMOS devices must be fixed high or low by using pull-up or pull-down circuitry. Each unused pin should be connected to V_{DD} or GND via a resistor if there is a possibility that it will be an output pin. All handling related to unused pins must be judged separately for each device and according to related specifications governing the device.

③ PRECAUTION AGAINST ESD

A strong electric field, when exposed to a MOS device, can cause destruction of the gate oxide and ultimately degrade the device operation. Steps must be taken to stop generation of static electricity as much as possible, and quickly dissipate it when it has occurred. Environmental control must be adequate. When it is dry, a humidifier should be used. It is recommended to avoid using insulators that easily build up static electricity. Semiconductor devices must be stored and transported in an anti-static container, static shielding bag or conductive material. All test and measurement tools including work benches and floors should be grounded. The operator should be grounded using a wrist strap. Semiconductor devices must not be touched with bare hands. Similar precautions need to be taken for PW boards with mounted semiconductor devices.

④ STATUS BEFORE INITIALIZATION

Power-on does not necessarily define the initial status of a MOS device. Immediately after the power source is turned ON, devices with reset functions have not yet been initialized. Hence, power-on does not guarantee output pin levels, I/O settings or contents of registers. A device is not initialized until the reset signal is received. A reset operation must be executed immediately after power-on for devices with reset functions.

⑤ POWER ON/OFF SEQUENCE

In the case of a device that uses different power supplies for the internal operation and external interface, as a rule, switch on the external power supply after switching on the internal power supply. When switching the power supply off, as a rule, switch off the external power supply and then the internal power supply. Use of the reverse power on/off sequences may result in the application of an overvoltage to the internal elements of the device, causing malfunction and degradation of internal elements due to the passage of an abnormal current.

The correct power on/off sequence must be judged separately for each device and according to related specifications governing the device.

⑥ INPUT OF SIGNAL DURING POWER OFF STATE

Do not input signals or an I/O pull-up power supply while the device is not powered. The current injection that results from input of such a signal or I/O pull-up power supply may cause malfunction and the abnormal current that passes in the device at this time may cause degradation of internal elements. Input of signals during the power off state must be judged separately for each device and according to related specifications governing the device.

- **The information in this document is current as of December, 2007. The information is subject to change without notice. For actual design-in, refer to the latest publications of NEC Electronics data sheets or data books, etc., for the most up-to-date specifications of NEC Electronics products. Not all products and/or types are available in every country. Please check with an NEC Electronics sales representative for availability and additional information.**
- No part of this document may be copied or reproduced in any form or by any means without the prior written consent of NEC Electronics. NEC Electronics assumes no responsibility for any errors that may appear in this document.
- NEC Electronics does not assume any liability for infringement of patents, copyrights or other intellectual property rights of third parties by or arising from the use of NEC Electronics products listed in this document or any other liability arising from the use of such products. No license, express, implied or otherwise, is granted under any patents, copyrights or other intellectual property rights of NEC Electronics or others.
- Descriptions of circuits, software and other related information in this document are provided for illustrative purposes in semiconductor product operation and application examples. The incorporation of these circuits, software and information in the design of a customer's equipment shall be done under the full responsibility of the customer. NEC Electronics assumes no responsibility for any losses incurred by customers or third parties arising from the use of these circuits, software and information.
- While NEC Electronics endeavors to enhance the quality, reliability and safety of NEC Electronics products, customers agree and acknowledge that the possibility of defects thereof cannot be eliminated entirely. To minimize risks of damage to property or injury (including death) to persons arising from defects in NEC Electronics products, customers must incorporate sufficient safety measures in their design, such as redundancy, fire-containment and anti-failure features.
- NEC Electronics products are classified into the following three quality grades: "Standard", "Special" and "Specific".

The "Specific" quality grade applies only to NEC Electronics products developed based on a customer-designated "quality assurance program" for a specific application. The recommended applications of an NEC Electronics product depend on its quality grade, as indicated below. Customers must check the quality grade of each NEC Electronics product before using it in a particular application.

"Standard": Computers, office equipment, communications equipment, test and measurement equipment, audio and visual equipment, home electronic appliances, machine tools, personal electronic equipment and industrial robots.

"Special": Transportation equipment (automobiles, trains, ships, etc.), traffic control systems, anti-disaster systems, anti-crime systems, safety equipment and medical equipment (not specifically designed for life support).

"Specific": Aircraft, aerospace equipment, submersible repeaters, nuclear reactor control systems, life support systems and medical equipment for life support, etc.

The quality grade of NEC Electronics products is "Standard" unless otherwise expressly specified in NEC Electronics data sheets or data books, etc. If customers wish to use NEC Electronics products in applications not intended by NEC Electronics, they must contact an NEC Electronics sales representative in advance to determine NEC Electronics' willingness to support a given application.

(Note)

- (1) "NEC Electronics" as used in this statement means NEC Electronics Corporation and also includes its majority-owned subsidiaries.
- (2) "NEC Electronics products" means any product developed or manufactured by or for NEC Electronics (as defined above).