

# Am25LS164 • Am54LS/74LS164

## 8-Bit Serial-In, Parallel-Out Shift Register

### DISTINCTIVE CHARACTERISTICS

- Gated serial inputs
- Asynchronous clear
- Am25LS devices offer the following improvements over Am54/74LS
  - Higher speed
  - 50mV lower  $V_{OL}$  at  $I_{OL} = 8mA$
  - Twice the fan-out over military range
  - 440 $\mu$ A source current at HIGH output
- 100% product assurance screening to MIL-STD-883 requirements

### FUNCTIONAL DESCRIPTION

The Am25LS164 and Am54LS/74LS164 are eight-bit, serial in/parallel out shift registers built using advanced Low-Power Schottky processing. A gated input provides enable/disable control over incoming data such that the data can be entered or logic zeros can be entered into the register.

An asynchronous clear input can be used to simultaneously clear the eight flip-flops in the device. When the clear input is LOW, all internal flip-flops are forced LOW independent of the clock input. An incoming data bit is entered into the  $Q_a$  flip-flop and the data in all internal flip-flops is shifted right on the LOW-to-HIGH transition of the clock input.

The Am54LS/74LS164 is a standard performance version of the Am25LS164. See appropriate electrical characteristic tables for detailed Am25LS improvements.

### LOGIC DIAGRAM

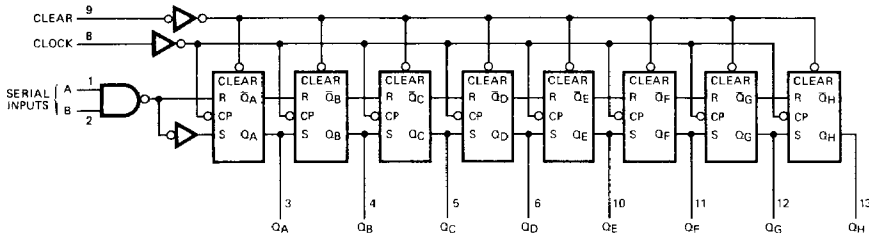

### CONNECTION DIAGRAM Top View

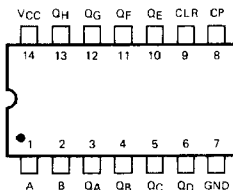

Note: Pin 1 is marked for orientation.

### LOGIC SYMBOL

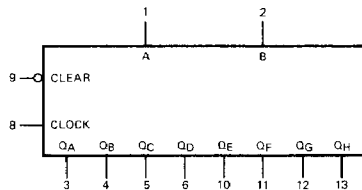

$V_{CC}$  = Pin 14  
GND = Pin 7

# Am25LS/54LS/74LS164

## Am25LS164

### ELECTRICAL CHARACTERISTICS

The Following Conditions Apply Unless Otherwise Specified:

COM'L	$T_A = 0^\circ\text{C to } +70^\circ\text{C}$	$V_{CC} = 5.0\text{V } \pm 5\%$	MIN. = 4.75V	MAX. = 5.25V
MIL	$T_A = -55^\circ\text{C to } +125^\circ\text{C}$	$V_{CC} = 5.0\text{V } \pm 10\%$	MIN. = 4.50V	MAX. = 5.50V

### DC CHARACTERISTICS OVER OPERATING RANGE

Parameters	Description	Test Conditions (Note 1)	Min.	Typ. (Note 2)	Max.	Units	
$V_{OH}$	Output HIGH Voltage	$V_{CC} = \text{MIN.}, I_{OH} = -440\mu\text{A}$ $V_{IN} = V_{IH}$ or $V_{IL}$	MIL	2.5	3.4		Volts
			COM'L	2.7	3.4		
$V_{OL}$	Output LOW Voltage	$V_{CC} = \text{MIN.}$ $V_{IN} = V_{IH}$ or $V_{IL}$	$I_{OL} = 4.0\text{mA}$		0.25	0.4	Volts
			$I_{OL} = 8.0\text{mA}$		0.35	0.45	
$V_{IH}$	Input HIGH Level	Guaranteed input logical HIGH voltage for all inputs	2.0			Volts	
$V_{IL}$	Input LOW Level	Guaranteed input logical LOW voltage for all inputs	MIL			0.7	Volts
			COM'L			0.8	
$V_I$	Input Clamp Voltage	$V_{CC} = \text{MIN.}, I_{IN} = -18\text{mA}$			-1.5	Volts	
$I_{IL}$	Input LOW Current	$V_{CC} = \text{MAX.}, V_{IN} = 0.4\text{V}$	Clock, Clear			-0.36	mA
			A, B			-0.4	
$I_{IH}$	Input HIGH Current	$V_{CC} = \text{MAX.}, V_{IN} = 2.7\text{V}$			20	$\mu\text{A}$	
$I_I$	Input HIGH Current	$V_{CC} = \text{MAX.}, V_{IN} = 7.0\text{V}$			0.1	mA	
$I_{SC}$	Output Short Circuit Current (Note 3)	$V_{CC} = \text{MAX.}$	-15		-85	mA	
$I_{CC}$	Power Supply Current (Note 4)	$V_{CC} = \text{MAX.}$		16	27	mA	

- Notes: 1. For conditions shown as MIN. or MAX., use the appropriate value specified under Electrical Characteristics for the applicable device type.  
 2. Typical limits are at  $V_{CC} = 5.0\text{V}$ ,  $25^\circ\text{C}$  ambient and maximum loading.  
 3. Not more than one output should be shorted at a time. Duration of the short circuit test should not exceed one second.  
 4. Measured with outputs open, serial inputs grounded, and a momentary ground, then 4.5V applied to the clear input.

## Am25LS • Am54LS/74LS

### MAXIMUM RATINGS (Above which the useful life may be impaired)

Storage Temperature	-65°C to +150°C
Temperature (Ambient) Under Bias	-55°C to +125°C
Supply Voltage to Ground Potential Continuous	-0.5V to +7.0V
DC Voltage Applied to Outputs for High Output State	-0.5V to + $V_{CC}$ max.
DC Input Voltage	-0.5V to +7.0V
DC Output Current, Into Outputs	30mA
DC Input Current	-30mA to +5.0mA

#### DEFINITION OF FUNCTIONAL TERMS

- A, B** The serial inputs to the device. If either the A input is LOW or the B input is LOW, the  $Q_A$  flip-flop will be set LOW on the LOW-to-HIGH transition of the clock.
- Clear** An asynchronous master reset for the eight flip-flops in the device. When the clear input is LOW, all internal flip-flops are set LOW independent of the clock.
- $Q_A$ - $Q_H$**  The eight true outputs of the eight-bit register.
- Clock** The clock input to the register. Data is entered into the register on the LOW-to-HIGH transition of the clock input.

#### Metallization and Pad Layout

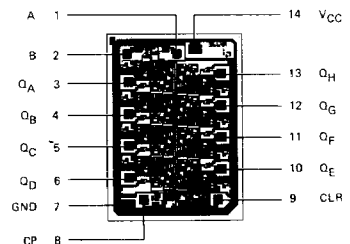

DIE SIZE 0.066" X 0.090"

## Am54LS/74LS164

## ELECTRICAL CHARACTERISTICS

The Following Conditions Apply Unless Otherwise Specified:

COM'L  $T_A = 0^\circ\text{C to } +70^\circ\text{C}$   $V_{CC} = 5.0\text{V} \pm 5\%$  MIN. = 4.75V MAX. = 5.25V  
 MIL  $T_A = -55^\circ\text{C to } +125^\circ\text{C}$   $V_{CC} = 5.0\text{V} \pm 10\%$  MIN. = 4.50V MAX. = 5.50V

## DC CHARACTERISTICS OVER OPERATING RANGE

Parameters	Description	Test Conditions (Note 1)	Min.	Typ. (Note 2)	Max.	Units	
$V_{OH}$	Output HIGH Voltage	$V_{CC} = \text{MIN.}, I_{OH} = -400\mu\text{A}$ $V_{IN} = V_{IH} \text{ or } V_{IL}$	MIL	2.5	3.4		Volts
			COM'L	2.7	3.4		
$V_{OL}$	Output LOW Voltage	$V_{CC} = \text{MIN.}$ $V_{IN} = V_{IH} \text{ or } V_{IL}$	All, $I_{OL} = 4.0\text{mA}$		0.25	0.4	Volts
			74LS only, $I_{OL} = 8.0\text{mA}$		0.35	0.5	
$V_{IH}$	Input HIGH Level	Guaranteed input logical HIGH voltage for all inputs	2.0			Volts	
$V_{IL}$	Input LOW Level	Guaranteed input logical LOW voltage for all inputs	MIL			0.7	Volts
			COM'L			0.8	
$V_I$	Input Clamp Voltage	$V_{CC} = \text{MIN.}, I_{IN} = -18\text{mA}$			-1.5	Volts	
$I_{IL}$	Input LOW Current	$V_{CC} = \text{MAX.}, V_{IN} = 0.4\text{V}$			-0.4	mA	
$I_{IH}$	Input HIGH Current	$V_{CC} = \text{MAX.}, V_{IN} = 2.7\text{V}$			20	$\mu\text{A}$	
$I_I$	Input HIGH Current	$V_{CC} = \text{MAX.}, V_{IN} = 7.0\text{V}$			0.1	mA	
$I_{SC}$	Output Short Circuit Current (Note 3)	$V_{CC} = \text{MAX.}$	-15		-100	mA	
$I_{CC}$	Power Supply Current (Note 4)	$V_{CC} = \text{MAX.}$		16	27	mA	

- Notes: 1. For conditions shown as MIN. or MAX., use the appropriate value specified under Electrical Characteristics for the applicable device type.  
 2. Typical limits are at  $V_{CC} = 5.0\text{V}$ ,  $25^\circ\text{C}$  ambient and maximum loading.  
 3. Not more than one output should be shorted at a time. Duration of the short circuit test should not exceed one second.  
 4. Measured with outputs open, serial inputs grounded, and a momentary ground, then 4.5V applied to the clear input.

Am25LS • Am54LS/74LS  
 LOW POWER SCHOTTKY INPUT/OUTPUT  
 CURRENT INTERFACE CONDITIONS

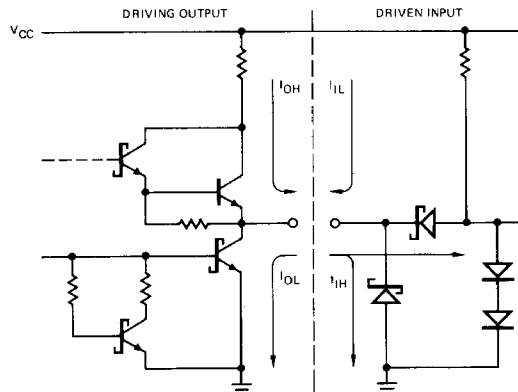

Note: Actual current flow direction shown.

# Am25LS/54LS/74LS164

## SWITCHING CHARACTERISTICS

( $T_A = +25^\circ\text{C}$ ,  $V_{CC} = 5.0\text{V}$ )

Parameters	Description	Am25LS			Am54LS/74LS			Units	Test Conditions
		Min.	Typ.	Max.	Min.	Typ.	Max.		
$t_{PLH}$	Clock to Output		14	20		17	27	ns	$C_L = 15\text{pF}$ $R_L = 2.0\text{k}\Omega$
$t_{PHL}$			15	22		21	32		
$t_{PHL}$	Clear to Output		19	29		24	36		
$t_{pw}$	Clock or Clear	17			20				
$t_s$	Data	10			15				
$t_h$	Data	5.0			5.0				
$t_s$	Clear Recovery Time	20			—	—			
$f_{max}$ (Note 1)	Maximum Clock Frequency	35	42		25	36		MHz	

Note 1. Per industry convention,  $f_{max}$  is the worst case value of the maximum device operating frequency with no constraints on  $t_r$ ,  $t_f$ , pulse width or duty cycle.

## Am25LS ONLY SWITCHING CHARACTERISTICS OVER OPERATING RANGE\*

Parameters	Description	Am25LS COM'L		Am25LS MIL		Units	Test Conditions
		Min.	Max.	Min.	Max.		
$t_{PLH}$	Clock to Output		26		30	ns	$C_L = 50\text{pF}$ $R_L = 2.0\text{k}\Omega$
$t_{PHL}$			30		35		
$t_{PHL}$	Clear to Output		37		42		
$t_{pw}$	Clock or Clear	22		25			
$t_s$	Data	13		15			
$t_h$	Data	5		5			
$t_s$	Clear Recovery Time	25		30			
$f_{max}$ (Note 1)	Maximum Clock Frequency	25		20		MHz	

\*AC performance over the operating temperature range is guaranteed by testing defined in Group A, Subgroup 9.

## TRUTH TABLE

Function	Clear	Clock	Serial		Q <sub>A</sub>	Q <sub>B</sub>	Q <sub>C</sub>	Q <sub>D</sub>	Q <sub>E</sub>	Q <sub>F</sub>	Q <sub>G</sub>	Q <sub>H</sub>
			A	B								
Clear	L	X	X	X	L	L	L	L	L	L	L	L
Shift Right	H	↑	L	L	L	Q <sub>A</sub>	Q <sub>B</sub>	Q <sub>C</sub>	Q <sub>D</sub>	Q <sub>E</sub>	Q <sub>F</sub>	Q <sub>G</sub>
	H	↑	L	H	L	Q <sub>A</sub>	Q <sub>B</sub>	Q <sub>C</sub>	Q <sub>D</sub>	Q <sub>E</sub>	Q <sub>F</sub>	Q <sub>G</sub>
	H	↑	H	L	L	Q <sub>A</sub>	Q <sub>B</sub>	Q <sub>C</sub>	Q <sub>D</sub>	Q <sub>E</sub>	Q <sub>F</sub>	Q <sub>G</sub>
	H	↑	H	H	H	Q <sub>A</sub>	Q <sub>B</sub>	Q <sub>C</sub>	Q <sub>D</sub>	Q <sub>E</sub>	Q <sub>F</sub>	Q <sub>G</sub>

L = LOW  
H = HIGH

↑ = LOW-to-HIGH transition  
X = Don't care

## ORDERING INFORMATION

Package Type	Temperature Range	Am25LS164 Order Number	SN54/74LS164 Order Number
Molded DIP	0°C to +70°C	AM25LS164PC	SN74LS164N
Hermetic DIP	0°C to +70°C	AM25LS164DC	SN74LS164J
Dice	0°C to +70°C	AM25LS164XC	SN74LS164X
Hermetic DIP	-55°C to +125°C	AM25LS164DM	SN54LS164J
Hermetic Flat Pak	-55°C to +125°C	AM25LS164FM	SN54LS164W
Dice	-55°C to +125°C	AM25LS164XM	SN54LS164X

## APPLICATION

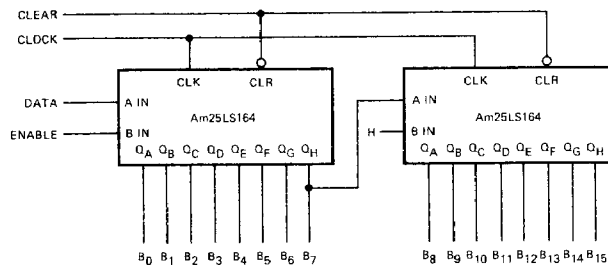

16-Bit Serial In Parallel Out Register.