

# UT63M14x MIL-STD-1553A/B Bus Transceiver

Data Sheet  
March 2005



## FEATURES

- ❑ 5-volt only operation ( $\pm 10\%$ )
- ❑ Completely monolithic bipolar technology
- ❑ Fit and functionally compatible to industry standard transceiver
- ❑ Idle low transmitter inputs and receiver outputs
- ❑ Dual-channel 50-mil center 24-lead Flatpack
- ❑ Dual-channel 100-mil center 36-pin DIP
- ❑ Full military operating temperature range,  $-55^{\circ}\text{C}$  to  $+125^{\circ}\text{C}$ , screened to QML Q or QML V requirements
- ❑ Radiation hardened to  $1.0\text{E}6$  rads(Si)
- ❑ Supports MIL-STD-1553 (UT63M147)
- ❑ Standard Microcircuit Drawing (SMD) 5962-93226 available

## INTRODUCTION

The monolithic UT63M14x Transceivers are complete transmitter and receiver pairs for MIL-STD-1553A and 1553B applications. Encoder and decoder interfaces are idle low.

The receiver section of the UT63M14x series accepts biphase-modulated Manchester II bipolar data from a MIL-STD-1553 data bus and produces TTL-level signal data at its RXOUT and  $\overline{\text{RXOUT}}$  outputs. An external RXEN input enables or disables the receiver outputs.

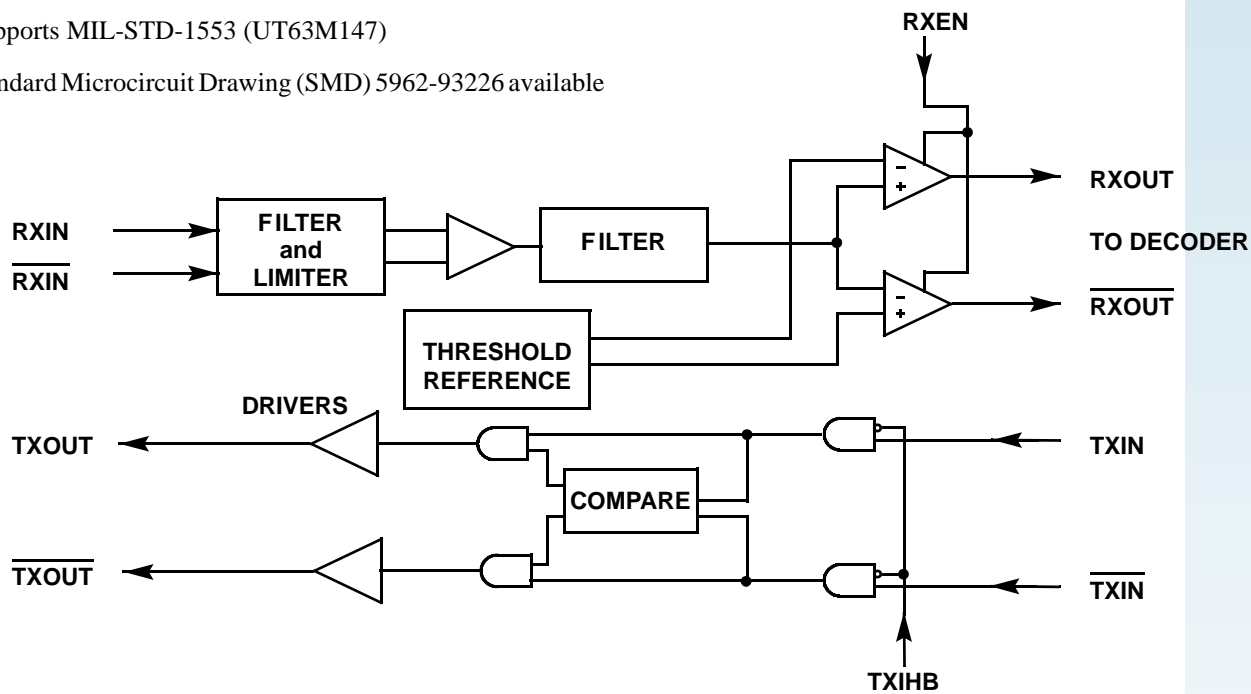

Figure 1. Functional Block Diagram

The transmitter section accepts biphasic TTL-level signal data at its TXIN and  $\overline{\text{TXIN}}$  and produces MIL-STD-1553 data signals. The transmitter's output voltage is typically 12 V<sub>PP,L-L</sub>. Activating the TXIHB input or setting both data inputs to the same logic level disables the transmitter outputs.

The UT63M14x series offers complete transmitter and receiver pairs packaged in a dual-channel 36-pin DIP or 24-lead flatpack configurations designed for use in any MIL-STD-1553 application.

**Legend for TYPE field:**

- TI = TTL input
- TO = TTL output
- DO = Differential output
- DI = Differential input
- DIO = Differential input/output
- ( ) = Channel designator
- [ ] = 24-lead flatpack

**TRANSMITTER**

NAME	PIN NUMBER	TYPE	DESCRIPTION
TXOUT <sup>1</sup> (A)	1 [1]	DO [DIO]	Transmitter outputs: TXOUT and $\overline{\text{TXOUT}}$ are differential data signals.
TXOUT (B)	10 [7]	DO [DIO]	
$\overline{\text{TXOUT}}$ <sup>1</sup> (A)	2 [2]	DO [DIO]	$\overline{\text{TXOUT}}$ is the half-cycle complement of TXOUT.
$\overline{\text{TXOUT}}$ (B)	11 [8]	DO [DIO]	
TXIHB (A)	34 [22]	TI	Transmitter inhibit: This is an active high input signal.
TXIHB (B)	25 [16]	TI	
TXIN (A)	35 [23]	TI	Transmitter input: TXIN and $\overline{\text{TXIN}}$ are complementary TTL-level Manchester II encoder inputs.
TXIN (B)	26 [17]	TI	
$\overline{\text{TXIN}}$ (A)	36 [24]	TI	$\overline{\text{TXIN}}$ is the complement of TXIN input.
$\overline{\text{TXIN}}$ (B)	27 [18]	TI	

**Note:**

1. The 24-lead flatpack internally connects TXOUT to RXIN (CHA, CHB) and  $\overline{\text{TXOUT}}$  to  $\overline{\text{RXIN}}$  ( $\overline{\text{CHA}}$ ,  $\overline{\text{CHB}}$ ) for each channel.

## RECEIVER

NAME	PIN NUMBER	TYPE	DESCRIPTION
RXOUT (A)	5 [4]	TO	Receiver outputs: RXOUT and $\overline{\text{RXOUT}}$ are complementary Manchester II decoder outputs.
RXOUT (B)	14 [10]	TO	
$\overline{\text{RXOUT}}$ (A)	8 [6]	TO	$\overline{\text{RXOUT}}$ is the complement of RXOUT output.
$\overline{\text{RXOUT}}$ (B)	17 [12]	TO	
RXEN (A)	6 [5]	TI	Receiver enable/disable: This is an active high input signal.
RXEN (B)	15 [11]	TI	
RXIN <sup>1</sup> (A)	29 [1]	DI [DIO]	Receiver input: RXIN and $\overline{\text{RXIN}}$ are biphas-modulated Manchester II bipolar inputs from MIL-STD-1553 data bus.
RXIN (B)	20 [7]	DI [DIO]	
$\overline{\text{RXIN}}$ <sup>1</sup> (A)	30 [2]	DI [DIO]	$\overline{\text{RXIN}}$ is the half-cycle complement of RXIN input.
$\overline{\text{RXIN}}$ (B)	21 [8]	DI [DIO]	

**Note:**

1. The 24-lead flatpack internally connects TXOUT to RXIN (CHA, CHB) and  $\overline{\text{TXOUT}}$  to  $\overline{\text{RXIN}}$  ( $\overline{\text{CHA}}$ ,  $\overline{\text{CHB}}$ ) for each channel.

## POWER AND GROUND

NAME	PIN NUMBER	TYPE	DESCRIPTION
V <sub>CC</sub> (A)	33 [20]	PWR	+5 V <sub>DC</sub> power (±10%)
V <sub>CC</sub> (B)	24 [14]	PWR	
GND (A)	3, 7, 31 [3,19,21]	GND	Ground reference
GND (B)	12, 16, 22 [9,13,15]	GND	

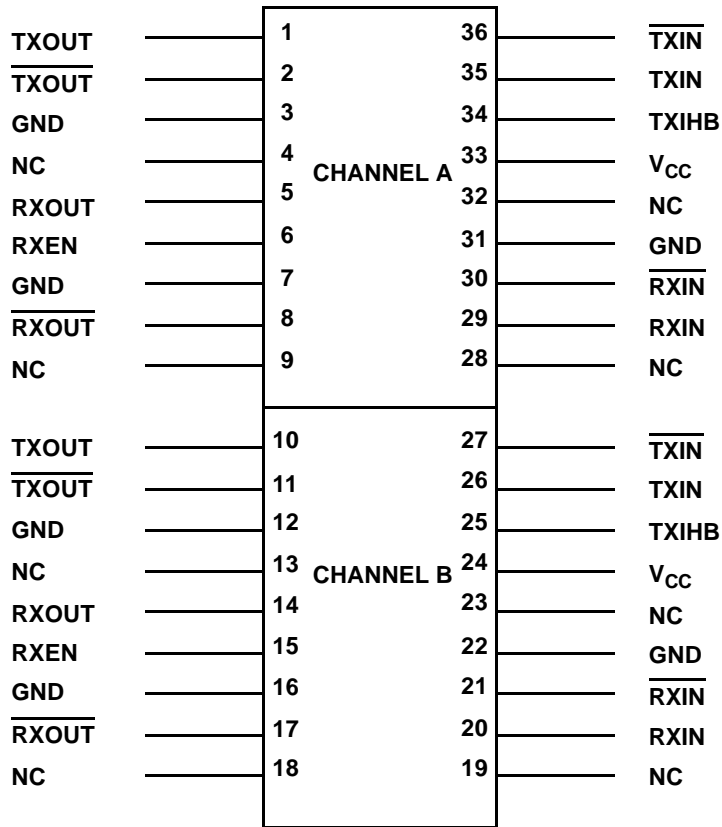

Figure 2a. Functional Pin Diagram -- Dual Channel (36)

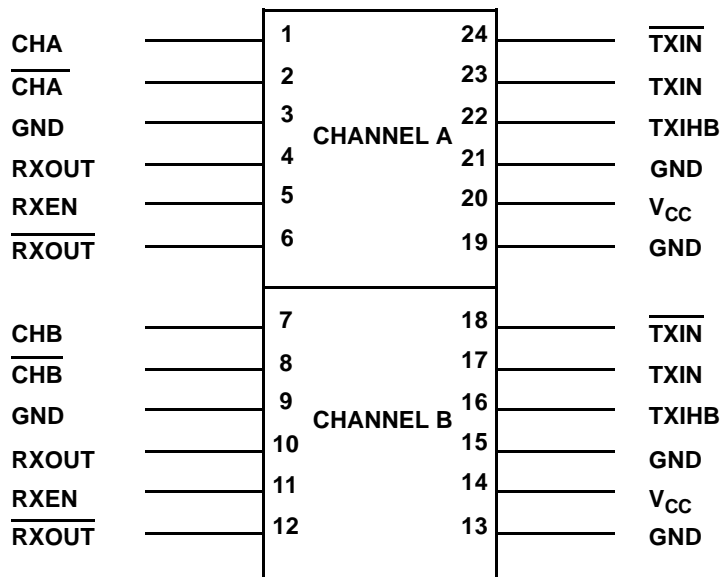

Figure 2b. Functional Pin Diagram -- Dual Channel (24)<sup>1</sup>

**Note:**

1. The 24-lead flatpack internally connects TXOUT to RXIN (CHA, CHB) and TXOUT-bar to RXIN-bar (CHA, CHB) for each channel.

## TRANSMITTER

The transmitter section accepts Manchester II biphas TTL data and converts this data into differential phase-modulated current drive. Transmitter current drivers are coupled to a MIL-STD-1553 data bus via a transformer driven from the TXOUT and  $\overline{\text{TXOUT}}$  terminals. Transmitter output terminals' non-transmitting state is enabled by asserting TXIHB (logic "1"), or by placing both TXIN and  $\overline{\text{TXIN}}$  at the same logic level. Table 1, Transmit Operating Mode, lists the functions for the output data in reference to the state of TXIHB. Figure 3 shows typical transmitter waveforms.

## RECEIVER

The receiver section accepts biphas differential data from a MIL-STD-1553 data bus at its RXIN and  $\overline{\text{RXIN}}$  inputs. The receiver converts input data to biphas Manchester II TTL format and is available for decoding at the RXOUT and  $\overline{\text{RXOUT}}$  terminals. The outputs RXOUT and  $\overline{\text{RXOUT}}$  represent positive and negative excursions (respectively) of the inputs RXIN and  $\overline{\text{RXIN}}$ . Figure 4 shows typical receiver output waveforms.

**Table 1. Transmit Operating Mode**

TXIN	$\overline{\text{TXIN}}$	TXIHB	TXOUT
x <sup>1</sup>	x	1	Off <sup>2</sup>
0	0	x	Off <sup>3</sup>
0	1	0	On
1	0	0	On
1	1	x	Off <sup>3</sup>

**Notes:**

1. x = Don't care.
2. Transmitter output terminals are in the non-transmitting mode during Off-time.
3. Transmitter output terminals are in the non-transmitting mode during Off-time, independent of TXIHB status.

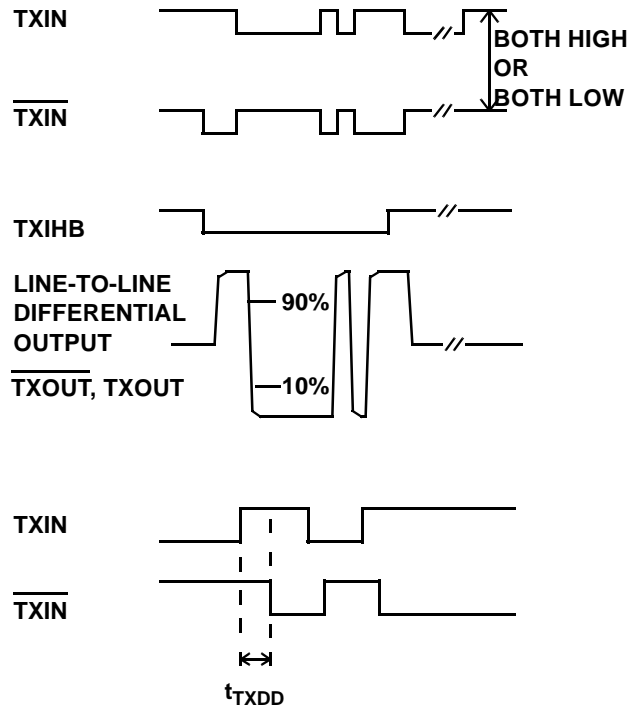

**Figure 3. Typical Transmitter Wave**

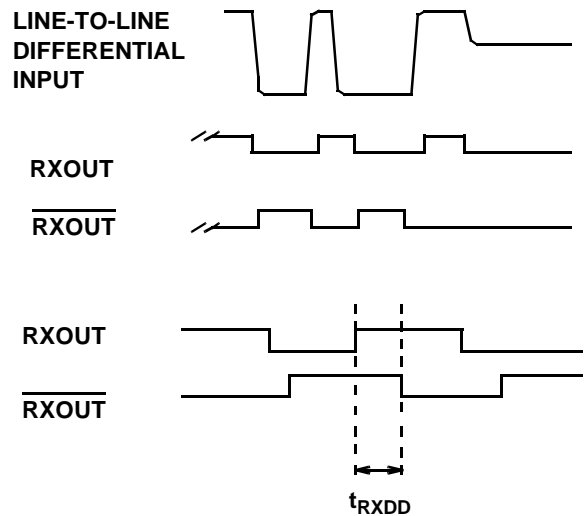

**Figure 4. Typical Receiver Waveforms**

## DATA BUS INTERFACE <sup>1</sup>

The designer can connect the UT63M14x to the data bus via a short-stub (direct-coupling) connection or a long-stub (transformer-coupling) connection. Use a short-stub connection when the distance from the isolation transformer to the data bus does not exceed a one-foot maximum. Use a long-stub connection when the distance from the isolation transformer exceeds the one-foot maximum and is less than twenty feet. Figure 5 shows various examples of bus coupling configurations. The UT63M14x series transceivers are designed to function with MIL-STD-1553A and 1553B compatible transformers.

**Note:**

1. The 24-lead flatpack internally connects TXOUT to RXIN and  $\overline{\text{TXOUT}}$  to  $\overline{\text{RXIN}}$  for each channel.

## RECOMMENDED THERMAL PROTECTION

All packages should mount to or contact a heat removal rail located in the printed circuit board. To insure proper heat transfer between the package and the heat removal rail, use a thermally-conductive material between the package and the heat removal rail. Use a material such as Mereco XLN-589 or equivalent to insure heat transfer between the package and heat removal rail.

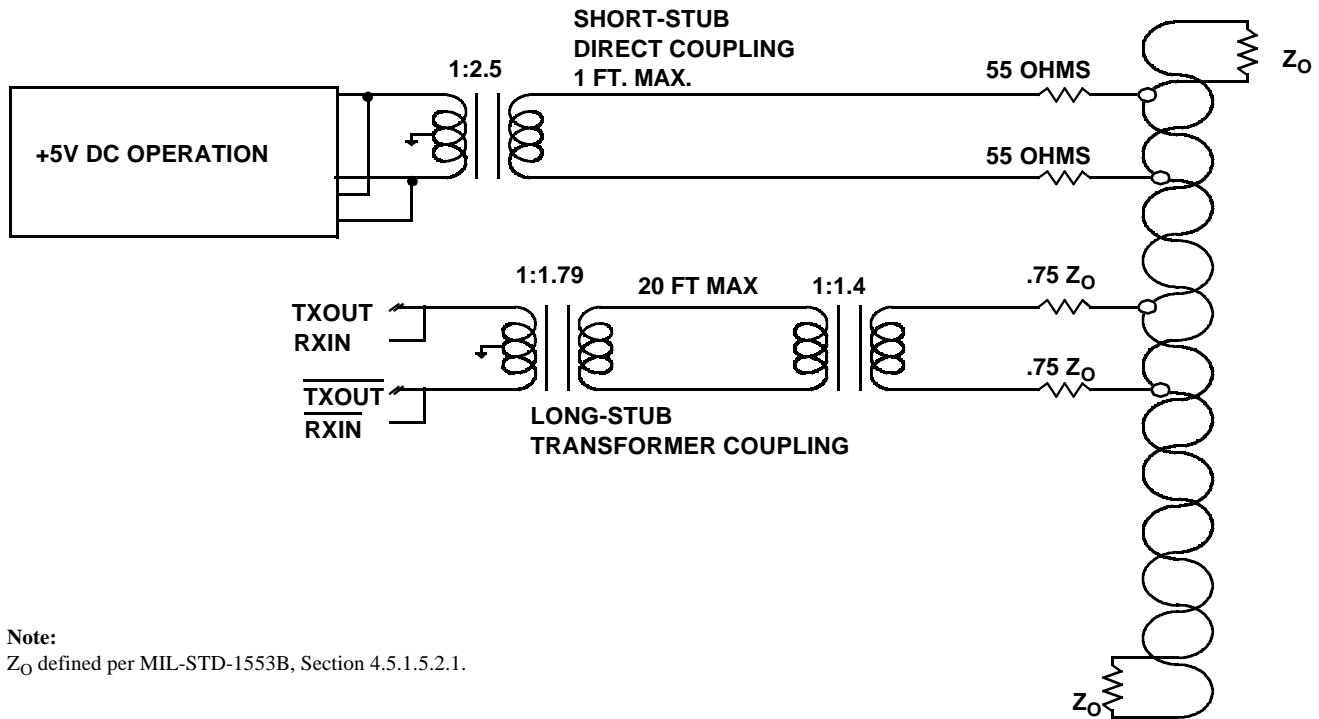

**Note:**

Z<sub>0</sub> defined per MIL-STD-1553B, Section 4.5.1.5.2.1.

Figure 5. Bus Coupling Configuration

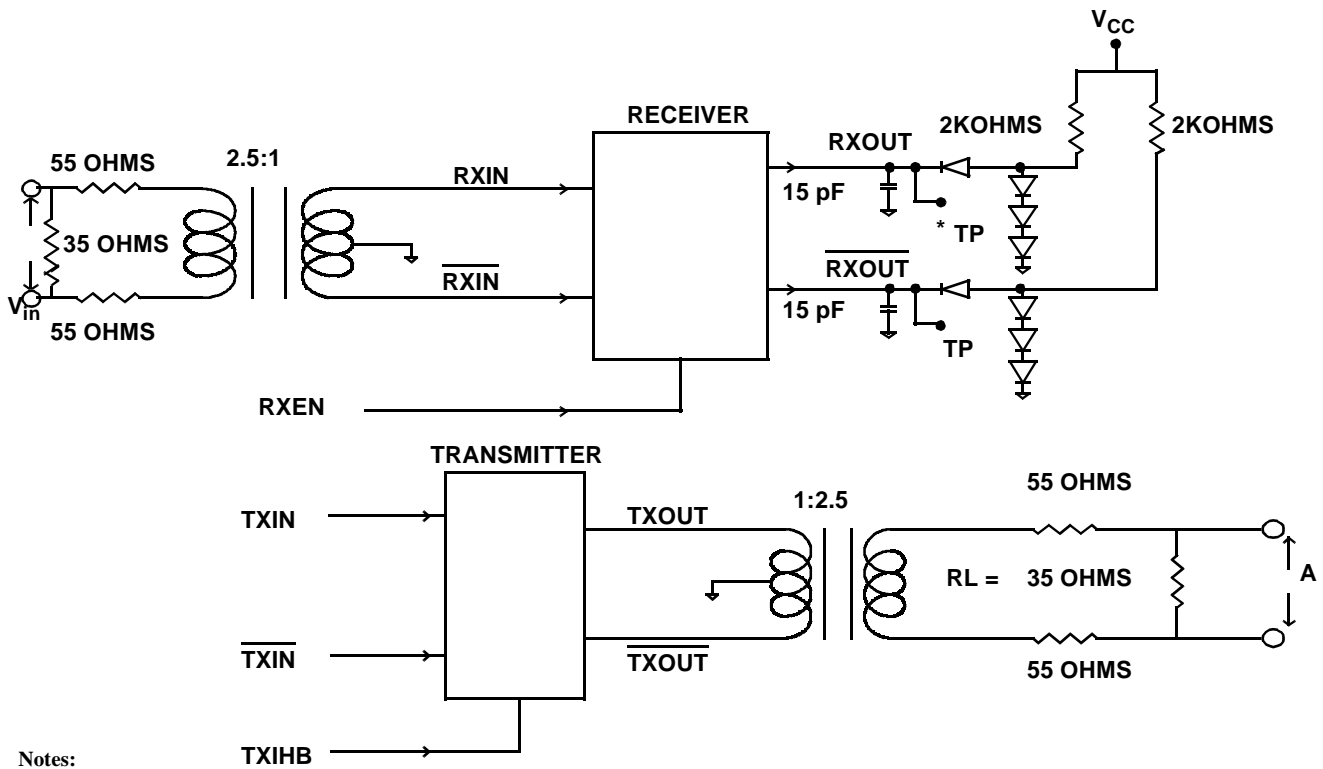

- Notes:
1. TP = Test point.
  2. RL removed for terminal input impedance test.
  3. TXOUT and RXIN tied together.  
TXOUT and RXIN tied together.

Figure 6. Direct Coupled Transceiver with Load

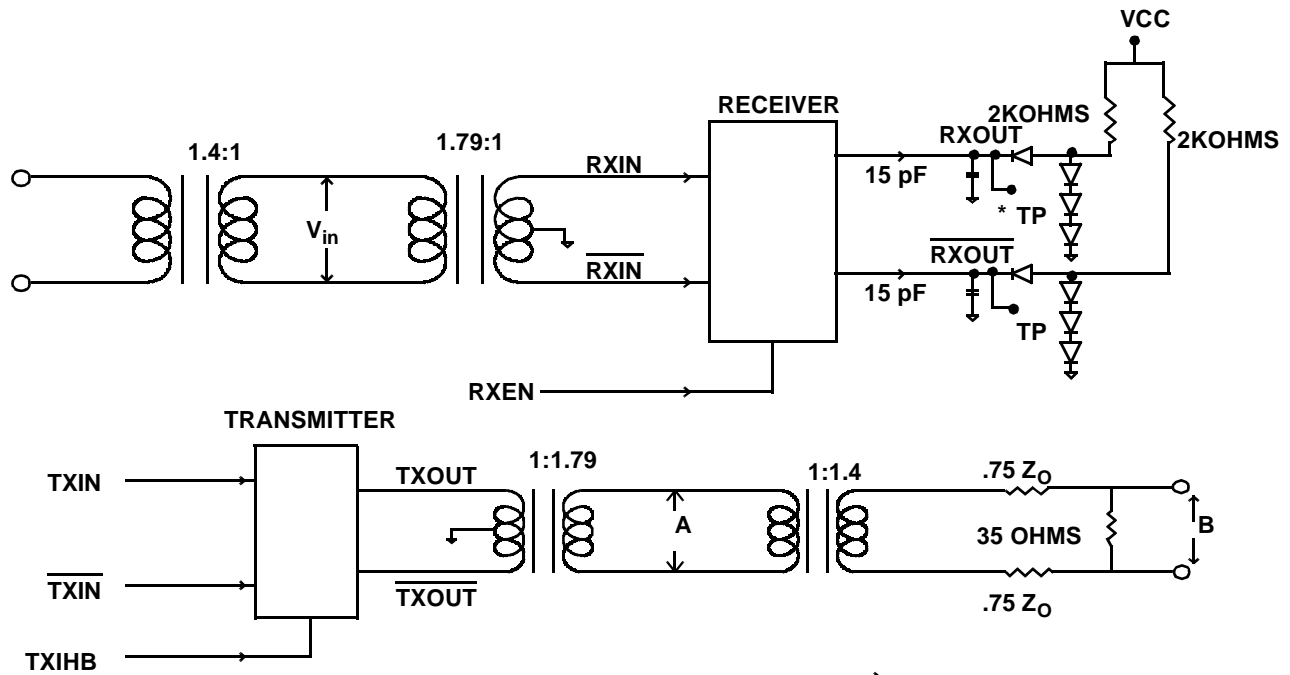

- Notes:
1. TP = Test point.
  2. RL removed for terminal impedance test.
  3. TXOUT and RXIN tied together.  
TXOUT and RXIN tied together.

Figure 7. Transformer Coupled Transceiver with Load

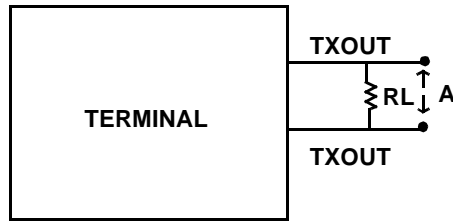

**Notes:**

1. Transformer Coupled Stub:  
Terminal is defined as transceiver plus isolation transformer. Point A is defined in figure 7.
2. Direct Coupled Stub:  
Terminal is defined as transceiver plus isolation transformer and fault resistors. Point A is defined in figure 6.

**Figure 8. Transceiver Test Circuit MIL-STD-1553**

**ABSOLUTE MAXIMUM RATINGS <sup>1</sup>**

PARAMETER	LIMITS	UNIT
V <sub>CC</sub>	-0.3 to +7.0	V
Input voltage range (receiver)	10	V <sub>PP, L-L</sub>
Logic input voltage range	-0.3 to +5.5	V
Power dissipation 100% duty cycle (per channel)	3.6	W
Thermal impedance junction to case <sup>2</sup>	6.0	°C/W
Maximum junction temperature	+175	°C
Storage temperature	-65 to +150	°C
Receiver common mode input voltage range	-5.0 to +5.0	V

**Notes:**

1. Stress outside the listed absolute maximum rating may cause permanent damage to the devices. This is a stress rating only, and functional operation of the device at these or any other conditions beyond limits indicated in the operational sections of this specification is not recommended. Exposure to absolute maximum rating conditions for extended periods may affect device reliability.
2. Mounting per MIL-STD-883, Method 1012.

**RECOMMENDED OPERATING CONDITIONS**

PARAMETER	LIMITS	UNIT
Supply voltage range	+4.50 to +5.50	V
Logic input voltage range	0 to +5.0	V
Receiver differential voltage	8.0	V <sub>P-P</sub>
Receiver common mode voltage range	±4.0	V
Driver peak output current	600	mA
Serial data rate	0.3 to 1	MHz
Case operating temperature range (T <sub>C</sub> )	-55 to +125	°C

**DC ELECTRICAL CHARACTERISTICS**<sup>1</sup> $V_{CC} = 5.0V \pm 10\%$  $-55^{\circ}C < T_C < +125^{\circ}C$ 

SYMBOL	PARAMETER	MINIMUM	MAXIMUM	UNIT	CONDITION
$V_{IL}$	Input low voltage		0.8	V	RXEN, TXIHB, TXIN, $\overline{TXIN}$
$V_{IH}$	Input high voltage	2.0		V	RXEN, TXIHB, TXIN, $\overline{TXIN}$
$I_{IL}$	Input low current	-0.1		mA	$V_{IL} = 0.4V$ ; RXEN, TXIHB, TXIN, $\overline{TXIN}$
$I_{IH}$	Input high current	-40	40	$\mu A$	$V_{IH} = 2.7V$ ; RXEN, TXIHB, TXIN, $\overline{TXIN}$
$V_{OL}$	Output low voltage		.55	V	$I_{OL} = 4mA$ ; RXOUT, $\overline{RXOUT}$
$V_{OH}$	Output high voltage	2.4		V	$I_{OH} = 0.4mA$ ; RXOUT, $\overline{RXOUT}$
$I_{CC}$	$V_{CC}$ supply current		22 200 380 650 740	mA mA mA mA mA	0% duty cycle (non-transmitting) 25% duty cycle ( $f = 1MHz$ ) 50% duty cycle ( $f = 1MHz$ ) 87.5% duty cycle ( $f = 1MHz$ ) 100% duty cycle ( $f = 1MHz$ ) <sup>2</sup>

**Note:**

1. All tests guaranteed per test figure 6.
2. Guaranteed but not tested.

## RECEIVER ELECTRICAL CHARACTERISTICS <sup>1</sup>

$V_{CC} = 5.0V \pm 10\%$

$-55^{\circ}C < T_C < +125^{\circ}C$

SYMBOL	PARAMETER	MINIMUM	MAXIMUM	UNIT	CONDITION
$C_{IN}^2$	Input capacitance		15	pF	RXEN; input $f = 1\text{MHz}$ @ 0V
$C_{OUT}^2$	Output capacitance		20	pF	RXOUT, $\overline{\text{RXOUT}}$ ; $f = 1\text{MHz}$ @ 0V
$V_{IC}^5$	Common mode input voltage	-5	5	V	Direct-coupled stub; input 1.2 V <sub>pp</sub> , 200ns rise/fall time $\pm 25\text{ns}$ , $f = 1\text{MHz}$
$V_{TH}$	Input threshold voltage <sup>4</sup> (no response)		0.20	V <sub>PPL-L</sub>	Transformer-coupled stub; input at $f = 1\text{MHz}$ , rise/fall time 200ns at (Receiver output 0 → 1 transition)
	Input threshold voltage (no response)		0.28	V <sub>PPL-L</sub>	Direct-coupled stub; input at $f = 1\text{MHz}$ , rise/fall time 200ns at (Receiver output 0 → 1 transition)
	Input threshold voltage <sup>4</sup> (response)	0.86	14.0	V <sub>PPL-L</sub>	Transformer-coupled stub; input at $f = 1\text{MHz}$ , rise/fall time 200ns at (Receiver output 0 → 1 transition)
	Input threshold voltage (response)	1.20	20.0 <sup>2</sup>	V <sub>PPL-L</sub>	Direct-coupled stub; input at $f = 1\text{MHz}$ , rise/fall time 200ns at (Receiver output 0 → 1 transition)
CMRR <sup>5</sup>	Common mode rejection ratio	Pass/Fail <sup>3</sup>		N/A	

### Notes:

1. All tests guaranteed per test figure 6.

2. Capacitance is measured only for initial qualification and after any process or design changes which may affect input or output capacitance.

3. Pass/fail criteria per the test method described in MIL-HDBK-1553 Appendix A, RT Validation Test Plan, Section 5.1.2.2, Common Mode Rejection.

4. Guaranteed by design.

5. Guaranteed to the limits specified if not tested.

## TRANSMITTER ELECTRICAL CHARACTERISTICS <sup>1</sup>

$V_{CC} = 5.0V \pm 10\%$

$-55^{\circ}C < T_C < +125^{\circ}C$

SYMBOL	PARAMETER	MINIMUM	MAXIMUM	UNIT	CONDITION
$V_O$	Output voltage swing per MIL-STD-1553B <sup>3, 5</sup> (see figure 9)	18	27	$V_{PP,L-L}$	Transformer-coupled stub, Figure 8, Point A; input $f = 1\text{MHz}$ , $R_L = 70\text{ ohms}$
	per MIL-STD-1553B (see figure 9)	6.0	9.0	$V_{PP,L-L}$	Direct-coupled stub, Figure 8, Point A; input $f = 1\text{MHz}$ , $R_L = 35\text{ ohms}$
	per MIL-STD-1553A <sup>5</sup> (see figure 9)	6.0	20	$V_{PP,L-L}$	Figure 7, Point A; input $f = 1\text{MHz}$ , $R_L = 35\text{ ohms}$
$V_{NS}^2$	Output noise voltage differential (see figure 9)		14	mV-RMS <sub>L-L</sub>	Transformer-coupled stub, Figure 8, Point A; input $f = \text{DC to } 10\text{MHz}$ , $R_L = 70\text{ ohms}$
			5	mV-RMS <sub>L-L</sub>	Direct-coupled stub, Figure 8, Point A; input $f = \text{DC to } 10\text{MHz}$ , $R_L = 35\text{ ohms}$
$V_{OS}^4$	Output symmetry	-250	+250	mV <sub>PP,L-L</sub>	Transformer-coupled stub, Figure 8, Point A; $R_L = 140\text{ ohms}$ , measurement taken $2.5\mu\text{s}$ after end of transmission
			-90	+90	mV <sub>PP,L-L</sub>
$V_{DIS}$	Output voltage distortion (overshoot or ring) (see figure 9)	-900	+900	mV <sub>peak,L-L</sub>	Transformer-coupled stub, Figure 8, Point A; $R_L = 70\text{ ohms}$
			-300	+300	mV <sub>peak,L-L</sub>
$C_{IN}^2$	Input capacitance		15	pF	RXEN, TXIHB, TXIN, $\overline{\text{TXIN}}$ ; input $f = 1\text{MHz @ } 0V$
$T_{IZ}^5$	Terminal input impedance	1		Kohm	Transformer-coupled stub, Figure 7, Point A; input $f = 75\text{KHz to } 1\text{MHz}$ (power on or power off; non-transmitting, $R_L$ removed from circuit).
			2		Kohm

### Notes:

1. All tests guaranteed per test figure 6.

2. Guaranteed by device characterization. Capacitance is measured only for initial qualification and after any process or design changes which may affect input or output capacitance.

3. For MIL-STD-1760, 22 Vp-p, L-L min.

4. Test in accordance with the method described in MIL-STD-1553B output symmetry, section 4.5.2.1.1.4.

5. Guaranteed to the limits specified if not tested.

## AC ELECTRICAL CHARACTERISTICS <sup>1</sup>

$V_{CC} = 5.0V \pm 10\%$

$-55^{\circ}C < T_C < +125^{\circ}C$

SYMBOL	PARAMETER	MINIMUM	MAXIMUM	UNIT	CONDITION
$t_R, t_F$	Transmitter output rise/fall time (see figure 10)	100	300	ns	Input $f = 1\text{MHz}$ 50% duty cycle: direct-coupled $R_L = 35$ ohms output at 10% through 90% points TXOUT, $\overline{\text{TXOUT}}$ . Figure 10.
$t_{RXDD}$	RXOUT delay	-200	200	ns	RXOUT to $\overline{\text{RXOUT}}$ , Figure 4.
$t_{TXDD}^3$	TXIN skew	-25	25	ns	TXIN to $\overline{\text{TXIN}}$ , Figure 3.
$t_{RZCD}$	Zero crossing distortion (see figure 11)	-150	150	ns	Direct-coupled stub; input $f = 1\text{MHz}$ , $3V_{PP}$ (skew INPUT $\pm 150\text{ns}$ ), rise/fall time 200ns.
$t_{TZCS}$	Zero crossing stability (see figure 11)	-25	25	ns	Input TXIN and $\overline{\text{TXIN}}$ should create Transmitter output zero crossings at 500ns, 1000ns, 1500ns, and 2000ns. These zero crossings should not deviate more than $\pm 25\text{ns}$ .
$t_{RDXOFF}^{3,4}$	Transmitter off; delay from inhibit active		100	ns	TXIN and $\overline{\text{TXIN}}$ toggling @ 1MHz; TXIHB transitions from logic zero to one, see figure 12.
$t_{DXON}^{3,5}$	Transmitter on; delay from inhibit inactive		150	ns	TXIN and $\overline{\text{TXIN}}$ toggling @ 1MHz; TXIHB transitions from logic one to zero, see figure 13.
$t_{RCV OFF}^3$	Receiver off		50	ns	Receiver turn off time, see figure 13.
$t_{RCV ON}^3$	Receiver on		50	ns	Receiver turn on time, see figure 13.
$t_{RCV PD}^3$	Receiver propagation		450	ns	Receiver propagation delay, see figure 13.
$t_{XMIT PD}^3$	Transmitter propagation		200	ns	Transmitter propagation delay, see figure 12.

### Notes:

1. All tests guaranteed per test figure 6.
2. Guaranteed by device characterization.
3. Supplied as a design limit but not guaranteed or tested.
4. Delay time from transmit inhibit (1.5V) rising to transmit off (280mV).
5. Delay time from not transmit inhibit (1.5V) falling to transmit off (1.2V).

**Table 2. Transformer Requirements**

<b>COUPLING TECHNIQUE</b>	$\pm 5V_{DC}$
DIRECT-COUPLED: Isolation Transformer Ratio	2.5:1
TRANSFORMER-COUPLED: Isolation Transformer Ratio	1.79:1
Coupling Transformer Ratio	1:1.4

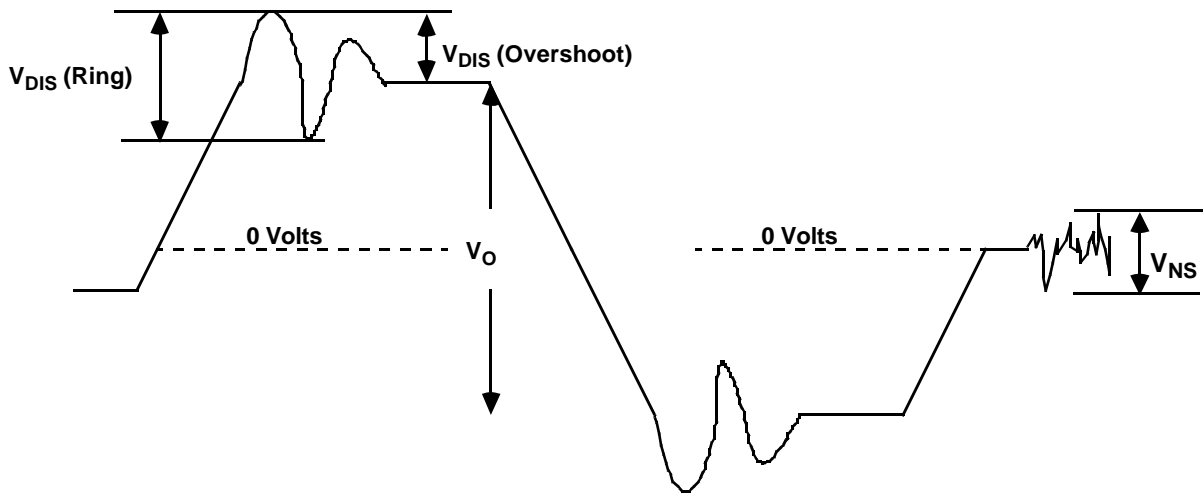

Figure 9. Transmitter Output Characteristics ( $V_{DIS}$ ,  $V_{NS}$ ,  $V_O$ )

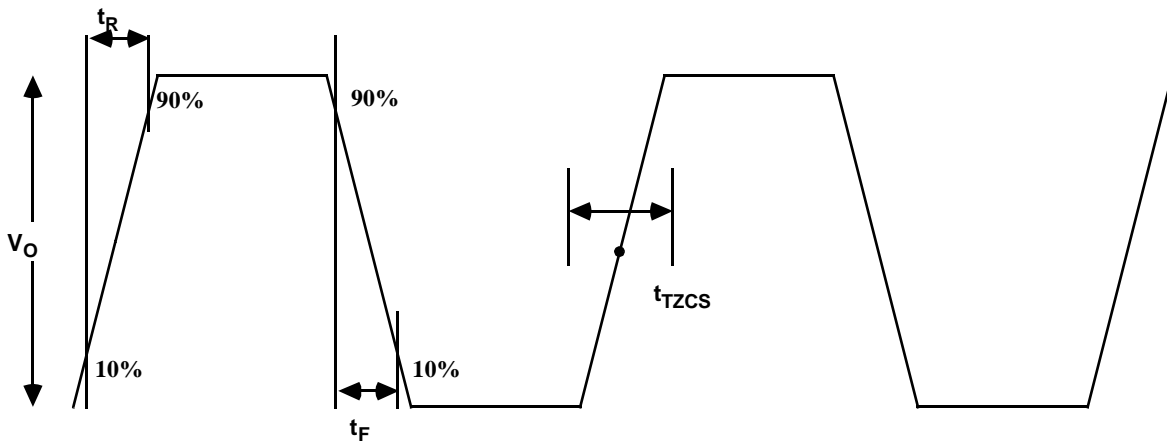

Figure 10. Transmitter Output Zero Crossing Stability, Rise Time, Fall Time ( $t_{TZCS}$ ,  $t_R$ ,  $t_F$ )

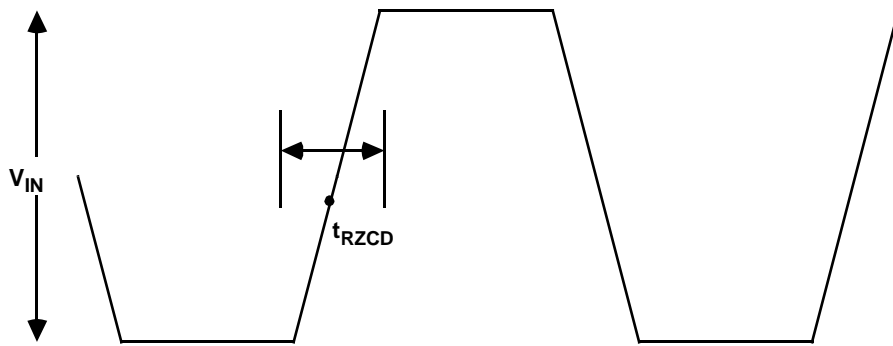

Figure 11. Receiver Input Zero Crossing Distortion ( $t_{RZCD}$ )

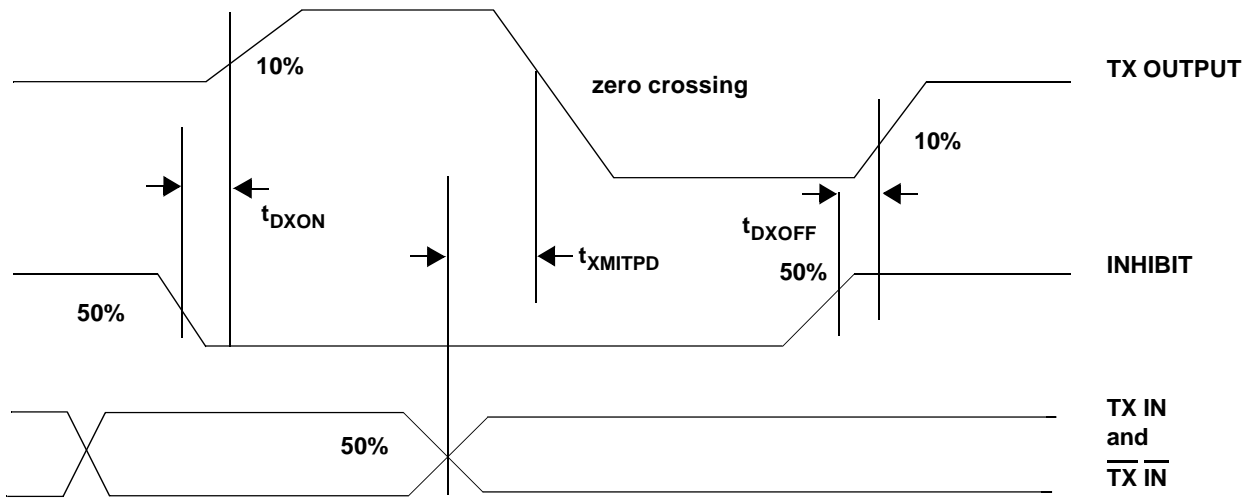

Figure 12. Transmitter Timing

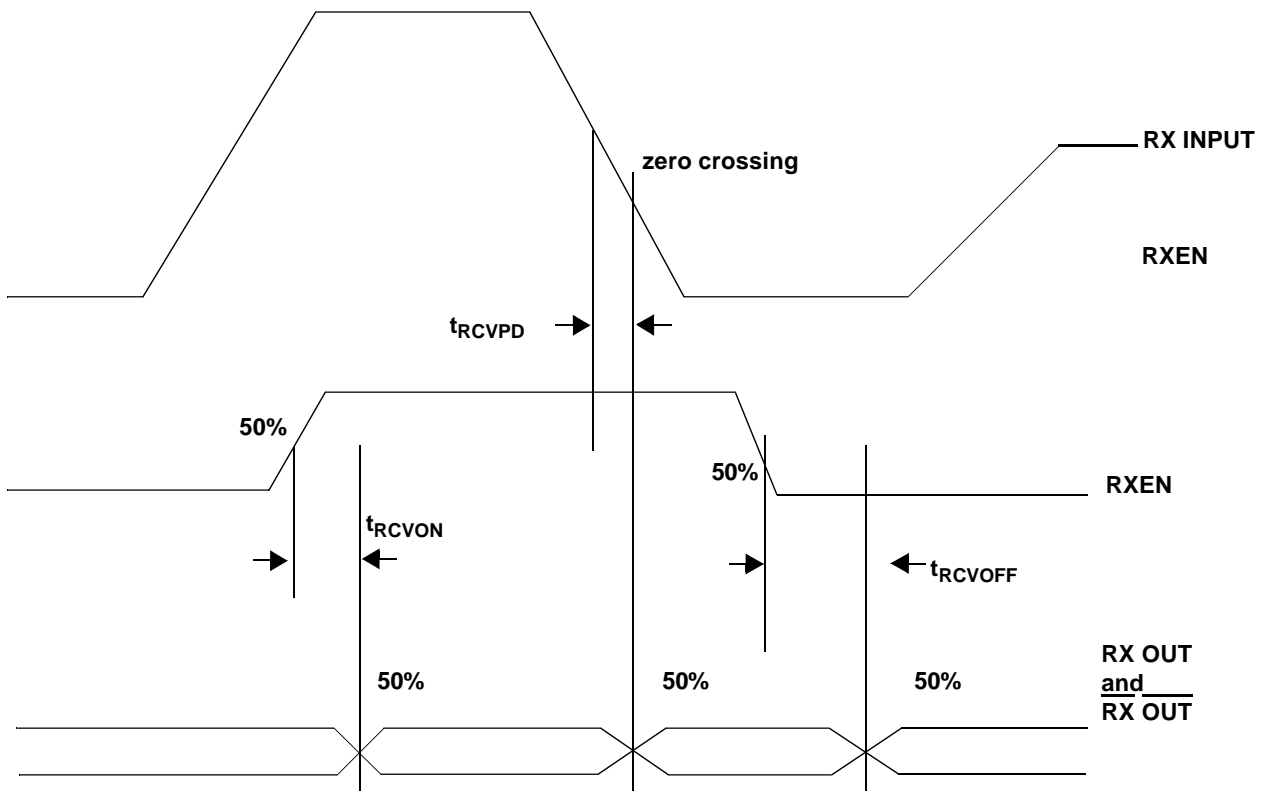
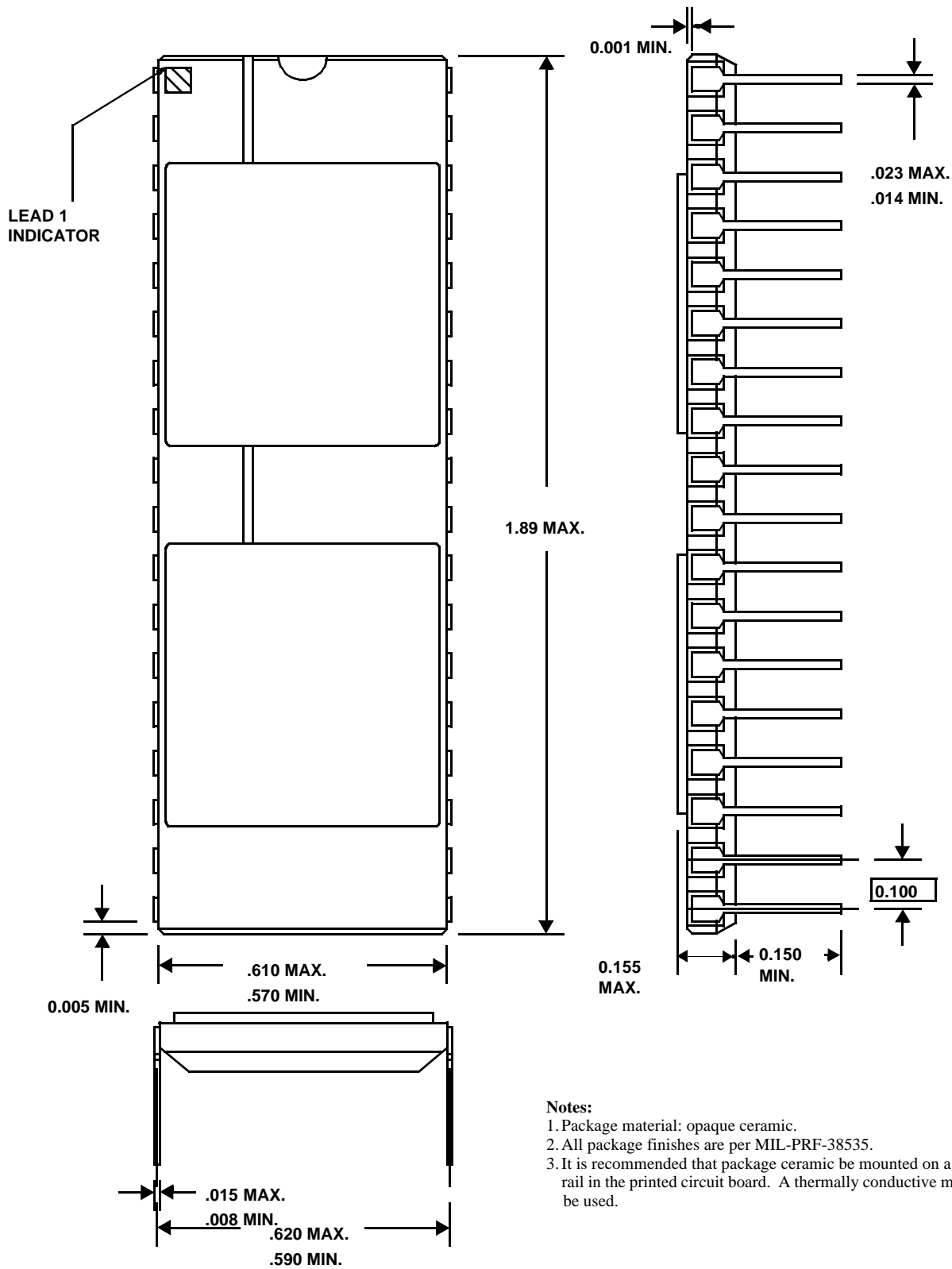

Figure 13. Receiving Timing



**Notes:**

1. Package material: opaque ceramic.
2. All package finishes are per MIL-PRF-38535.
3. It is recommended that package ceramic be mounted on a heat removal rail in the printed circuit board. A thermally conductive material should be used.

(AT SEATING PLANE)

**Figure 14. 36-Pin Side-Brazed DIP, Dual Cavity**

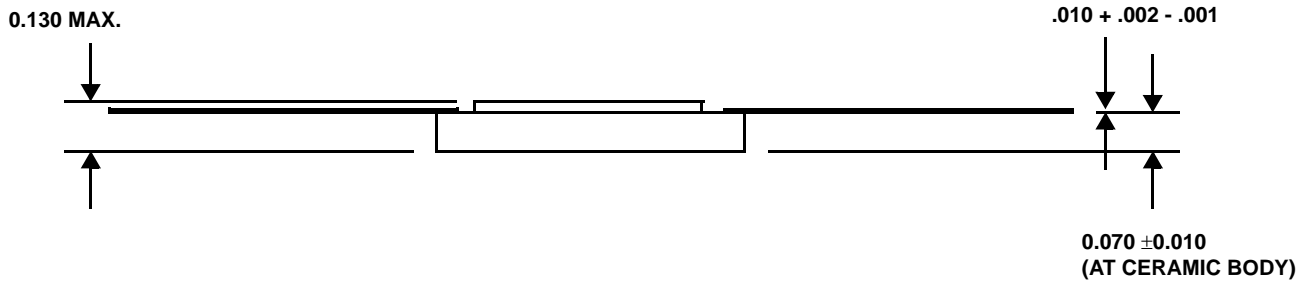
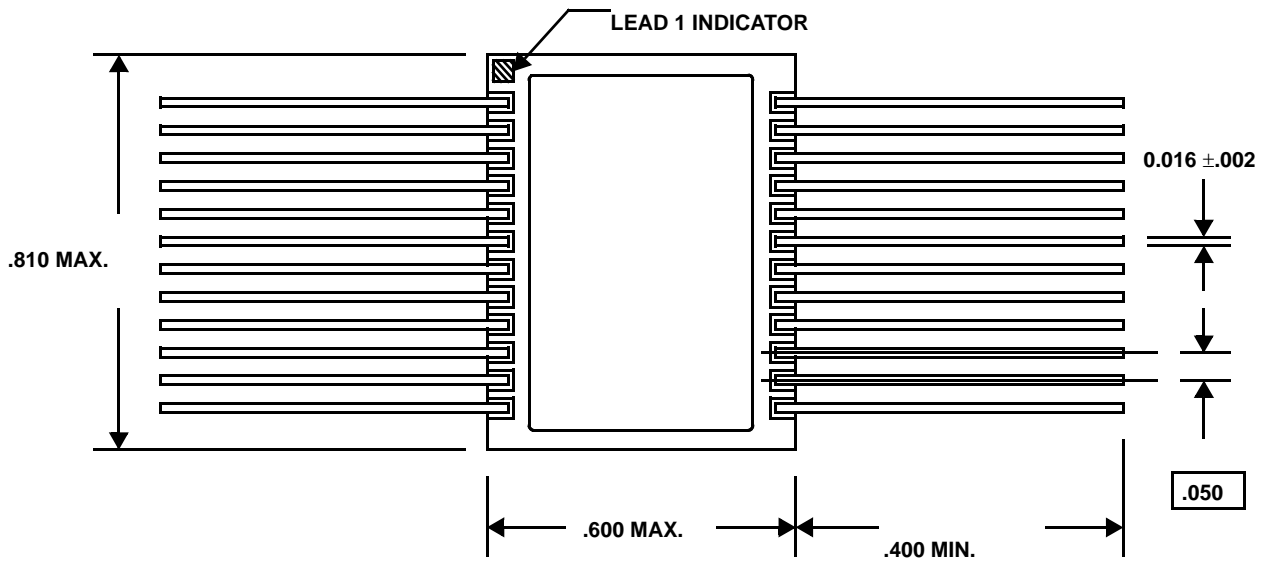

**Notes:**

1. Package material: opaque ceramic.
2. All package plating finishes are per MIL-PRF-38535.
3. It is recommended that package ceramic be mounted to a heat removal rail located in the printed circuit board. A thermally conductive material should be used.

**Figure 15. 24-Lead Flatpack, Dual Cavity  
(50-mil lead spacing)**

## ORDERING INFORMATION

### UT63M14x Monolithic Transceiver, 5V Operation: SMD

5962 \* 93226 \* \* \*

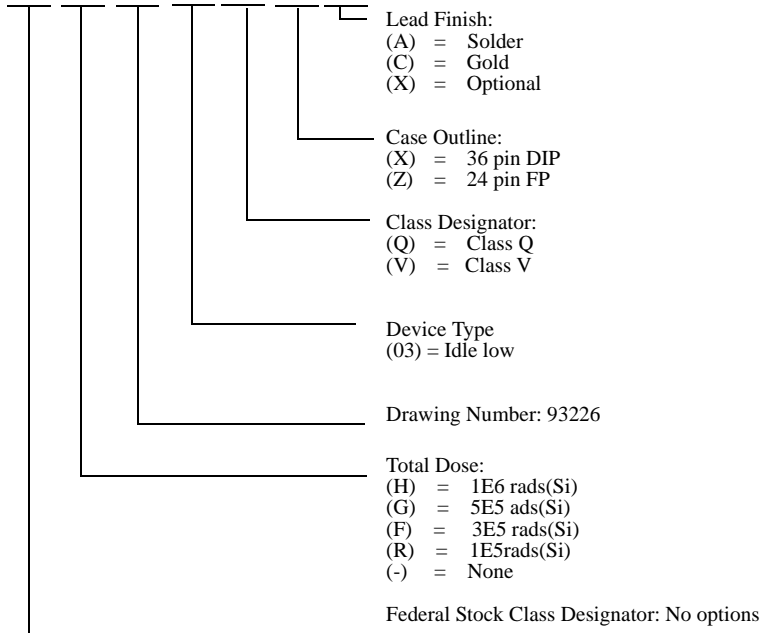

#### Notes:

1. Lead finish (A, C, or X) must be specified.
2. If an "X" is specified when ordering, part marking will match the lead finish and will be either "A" (solder) or "C" (gold).
3. Total dose must be specified for all QML Q and QML V devices.
4. Neutron irradiation limits will be added when available.

## UT63M14x Monolithic Transceiver, 5V Operation

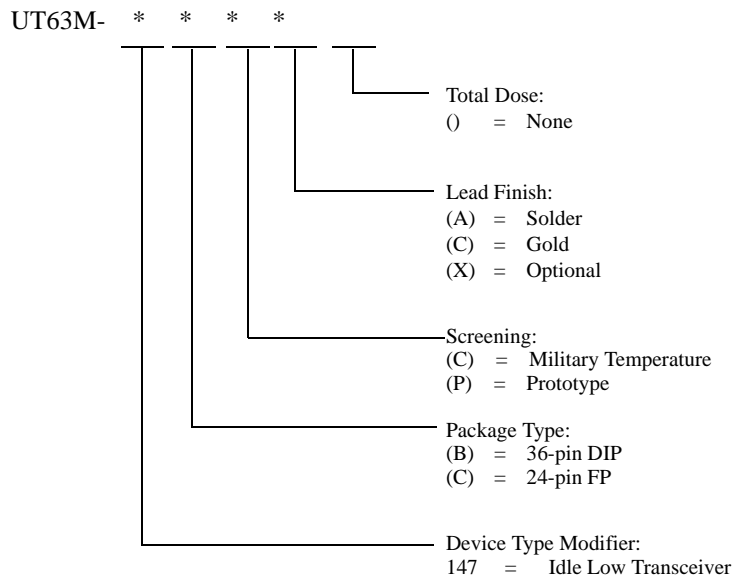

### Notes:

1. Lead finish (A, C, or X) must be specified.
2. If an "X" is specified when ordering, part marking will match the lead finish and will be either "A" (solder) or "C" (gold).
3. Military Temperature range devices are burned-in and tested at -55°C, room temperature, and 125°C. Radiation characteristics are neither tested nor guaranteed and may not be specified.
4. Devices have prototype assembly and are tested at 25°C only. Radiation characteristics are neither tested nor guaranteed and may not be specified. Lead finish is GOLD only.

**COLORADO**

Toll Free: 800-645-8862  
Fax: 719-594-8468

**INTERNATIONAL**

Tel: 805-778-9229  
Fax: 805-778-1980

**NORTHEAST**

Tel: 603-888-3975  
Fax: 603-888-4585

**SE AND MID-ATLANTIC**

Tel: 321-951-4164  
Fax: 321-951-4254

**WEST COAST**

Tel: 949-362-2260  
Fax: 949-362-2266

**CENTRAL**

Tel: 719-594-8017  
Fax: 719-594-8468

[www.aeroflex.com](http://www.aeroflex.com)    [info-ams@aeroflex.com](mailto:info-ams@aeroflex.com)

Aeroflex Colorado Springs, Inc., reserves the right to make changes to any products and services herein at any time without notice. Consult Aeroflex or an authorized sales representative to verify that the information in this data sheet is current before using this product. Aeroflex does not assume any responsibility or liability arising out of the application or use of any product or service described herein, except as expressly agreed to in writing by Aeroflex; nor does the purchase, lease, or use of a product or service from Aeroflex convey a license under any patent rights, copyrights, trademark rights, or any other of the intellectual rights of Aeroflex or of third parties.



Our passion for performance is defined by three attributes represented by these three icons: solution-minded, performance-driven and customer-focused