

# LI0402C221R-10

## PHYSICAL DIMENSIONS:

A	1.01 [.040]	+	0.18 [.007]
B	0.50 [.020]	+	0.20 [.008]
C	0.50 [.020]	+	0.20 [.008]
D	0.25 [.010]	+	0.15 [.006]

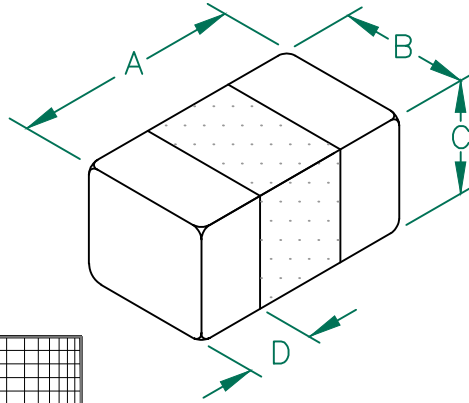

## ELECTRICAL CHARACTERISTICS:

Z @ 100MHz (Ω)	DCR (Ω)	Rated Current
Nominal	220	
Minimum	165	
Maximum	275	0.35 300 mA

NOTES: UNLESS OTHERWISE SPECIFIED

1. TAPED AND REELED per CURRENT EIA SPECIFICATIONS 7" REELS, 10,000 PCS/REEL, PAPER TAPE.
2. TERMINATION FINISH IS 100% TIN.
3. COMPONENTS SHOULD BE ADEQUATELY PREHEATED BEFORE SOLDERING.
4. OPERATING TEMP. RANGE: -40°C~+125°C. (INCLUDING SELF-HEATING)

Z vs FREQUENCY  
IMPEDANCE UNDER DC BIAS

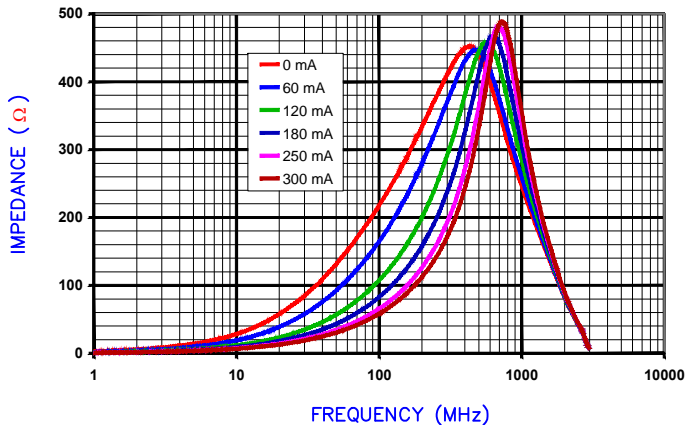

LAND PATTERNS FOR REFLOW SOLDERING

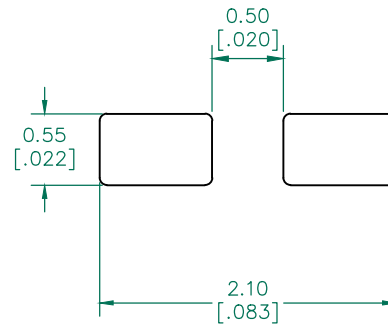

(For wave soldering, add 0.762 [.030] to this dimension.)

RECOMMENDED SOLDERING CONDITIONS

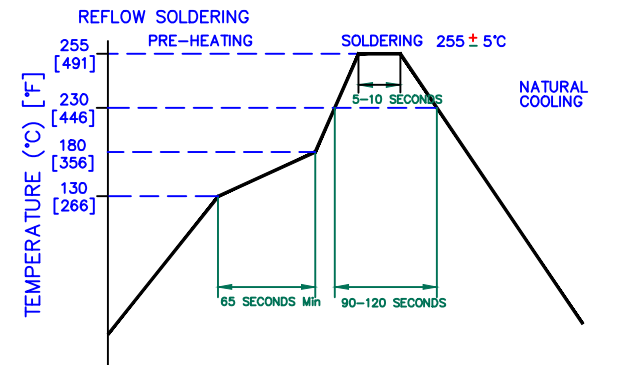

|Z|, R, AND X vs. FREQUENCY

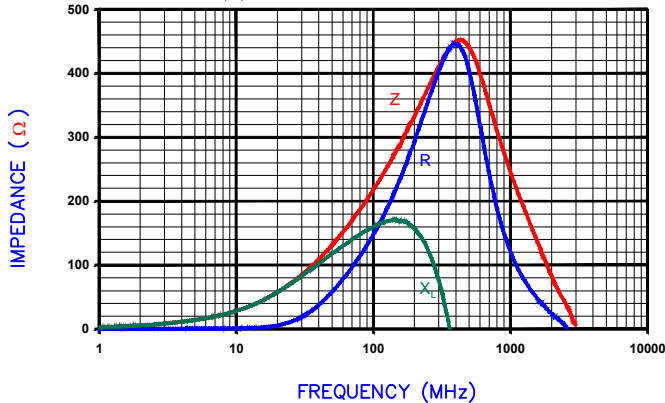

Z R X<sub>c</sub>

AGILENT E4991A RF Impedance/Material Analyzer  
HP 16194A Test Fixture. TEST REF. 5615



DIMENSIONS ARE IN mm [INCHES].				This print is the property of Laird Tech. and is loaned in confidence subject to return upon request and with the understanding that no copies shall be made without the written consent of Laird Tech. All rights to design or invention are reserved.		<b>Laird</b>	
D	UPDATE D DIMENSION	05/04/14	QU	PROJECT/PART NUMBER:	REV	PART TYPE:	DRAWN BY:
C	ADD OPERATING TEMPERATURE UPDATE LAIRD LOGO AND REFLOW CURVE	08/05/13	QU	LI0402C221R-10	D	CO-FIRE	TMB
B	UPDATE COMPANY LOGO	07/08/08	JRK	DATE:	SCALE:	NTS	SHEET:
A	ORIGINAL DRAFT	04/21/06	TMB	04/21/06			
REV	DESCRIPTION	DATE	INT	CAD #	TOOL #	-	1 of 1