

## features

- In normal condition, it works as a resistor and when excessive voltage is applied, it protects circuits by fusing quickly
- The same shape as RK73 series
- Suitable for both flow and reflow solderings
- Products with lead-free terminations meet EU RoHS requirements. EU RoHS regulation is not intended for Pb-glass contained in electrode, resistor element and glass.
- Recognized by safety standard UL1412. (0603 (1J) is not recognized)

## dimensions and construction

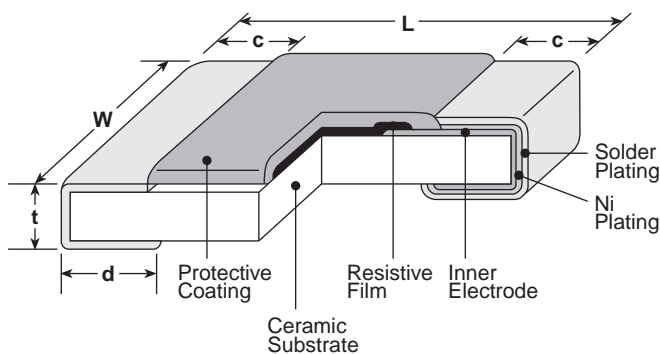

Type (Inch Size Code)	Dimensions inches (mm)				
	L	W	c	d	t
1J (0603)	.063±.008 (1.6±0.2)	.031±.004 (0.8±0.1)	.012±.004 (0.3±0.1)	.012±.004 (0.3±0.1)	.02±.004 (0.5±0.1)
2A (0805)	.079±.008 (2.0±0.2)	.049±.004 (1.25±0.1)	.016±.008 (0.4±0.2)	.012 <sup>+0.008</sup> <sub>-.004</sub> (0.3 <sup>+0.2</sup> <sub>-.01</sub> )	
2B (1206)	.126±.008 (3.2±0.2)	.063±.008 (1.6±0.2)	.02±.012 (0.5±0.3)	.016 <sup>+0.008</sup> <sub>-.004</sub> (0.4 <sup>+0.2</sup> <sub>-.01</sub> )	.024±.004 (0.6±0.1)
2E (1210)		.102±.008 (2.6±0.2)			
2H (2010)	.197±.008 (5.0±0.2)	.098±.008 (2.5±0.2)			
3A (2512)	.248±.008 (6.3±0.2)	.122±.008 (3.1±0.2)			

## ordering information

RF73	2B	T	TD	100	J
Type	Size Code	Termination Material	Packaging	Nominal Resistance	Tolerance
	1J: 0603 2A: 0805 2B: 1206 2E: 1210 2H: 2010 3A: 2512	T: Sn (Other termination styles may be available, please contact factory for options)	TD: 7" 4mm pitch punch paper (0603, 0805, 1206, 1210: 5,000 pieces/reel) TE: 7" 4mm pitch embossed plastic (0805, 1206, 1210, 2010, 2512: 4,000 pieces/reel)	2 significant figures + 1 multiplier "R" indicates decimal on value <10Ω	J: ±5%

For further information on packaging, please refer to Appendix A.

## applications and ratings

Part Designation	Power Rating @ 70°C	T.C.R. (ppm/°C) Max.	Resistance Range E-24	Resistance Tolerance	Fusing Characteristics					Operating Temperature Range	
					Fusing Power Resistance Range						Fusing Time
RF731J	0.063W	+1000 ~ -500 (1.0Ω-3.3Ω) ±500 (3.6Ω-100Ω)	1Ω-100Ω	J: ±5%	—	2.6W 1.0Ω	2.4W 1.1Ω-20Ω	2.1W 22Ω-100Ω	—	60 sec. max.	-55°C to +125°C
RF732A	0.1W	+1000 ~ -500 (0.2Ω-4.3Ω) ±500 (4.7Ω-510Ω)	0.2Ω-510Ω		3.0W 0.2Ω-0.47Ω	2.6W 0.51Ω-1.0Ω	2.4W 1.1Ω-20Ω	2.1W 22Ω-100Ω	2.0W 110Ω-510Ω		
RF732B	0.125W				3.75W 0.2Ω-0.47Ω	2.875W 0.51Ω-10Ω	2.5W 11Ω-24Ω	2.0W 27Ω-100Ω	1.75W 110Ω-510Ω		
RF732E	0.25W				4.5W 0.2Ω-0.47Ω	4.1W 0.51Ω-4.7Ω	3.5W 5.1Ω-27Ω	3.2W 30Ω-100Ω	3.0W 110Ω-510Ω		
RF732H	0.50W				5.5W 0.2Ω-0.47Ω	5.0W 0.51Ω-4.7Ω	4.0W 5.1Ω-27Ω	3.5W 30Ω-100Ω	3.2W 110Ω-510Ω		
RF733A	1.0W				6.5W 0.2Ω-0.47Ω	6.0W 0.51Ω-4.7Ω	5.0W 5.1Ω-30Ω	4.5W 33Ω-100Ω	4.0W 110Ω-510Ω		
					—	—	—	—	—		

Rated ambient temperature: +70°C

## environmental applications

### Derating Curve

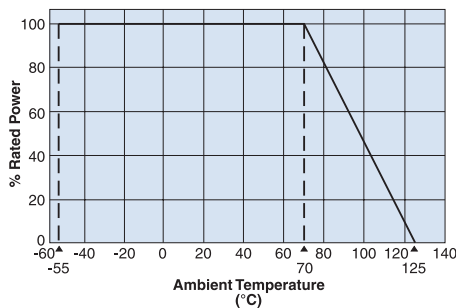

For resistors operated at an ambient temperature of 70°C or above, a power rating shall be derated in accordance with the above derating curve.

### One-Pulse Limiting Electric Power

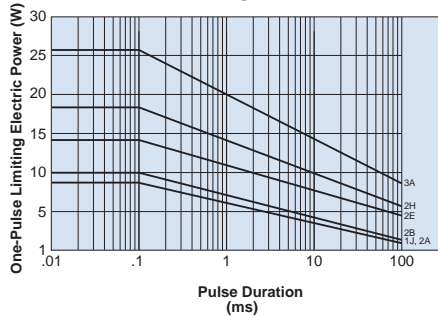

Please ask us about the resistance characteristic of continuous applied pulse. The pulse endurance values are not assured values, so be sure to check the products on actual equipment when you use them.

### Example of Fusing Characteristics

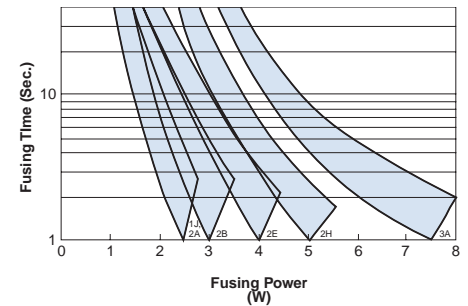

## Performance Characteristics

Parameter	Requirement $\Delta R \pm(\% + 0.1\Omega)$		Test Method
	Limit	Typical	
Resistance	Within specified tolerance	—	25°C
T.C.R.	Within specified T.C.R.	—	+25°C/-55°C and +25°C/+125°C
Overload (Short Time)	±5.0%	±2.0%	Rated voltage x 2 for 5 seconds (except 2E, 2H, 3A: x 1.5)
Resistance to Solder Heat	±3.0%	0.5%	260°C ± 5°C for 10 seconds ± 1 second
Rapid Change of Temperature	±0.5%: 2A~3A ±3.0%: 1J	±0.3%: 2A~3A ±0.6%: 1J	-55°C (30 minutes)/ +125°C (30 minutes) 5 cycles
Moisture Resistance	±5.0%	±2.0%	40°C ± 2°C, 90 - 95% RH, 500 hours, 1.5 hr ON, 0.5 hr OFF cycle
Endurance at 70°C	±5.0%	±1.0%	70°C ± 2°C, 1000 hours, 1.5 hr ON, 0.5 hr OFF cycle
High Temperature Exposure	±1.0%	±0.6%	+125°C, 100 hours