

## 2G bits DDR3 SDRAM

### EDJ2108DEBG (256M words × 8 bits) EDJ2116DEBG (128M words × 16 bits)

#### Specifications

- Density: 2G bits
- Organization
  - 32M words × 8 bits × 8 banks (EDJ2108DEBG)
  - 16M words × 16 bits × 8 banks (EDJ2116DEBG)
- Package
  - 78-ball FBGA (EDJ2108DEBG)
  - 96-ball FBGA (EDJ2116DEBG)
  - Lead-free (RoHS compliant) and Halogen-free
- Power supply: VDD, VDDQ = 1.5V ± 0.075V
- Data rate
  - 2133Mbps/1866Mbps/1600Mbps/1333Mbps (max)
- Spread Spectrum Clock (SSC)
  - Sweep rate: down spread 1% (20kHz to 60kHz)
- 1KB page size (EDJ2108DEBG)
  - Row address: A0 to A14
  - Column address: A0 to A9
- 2KB page size (EDJ2116DEBG)
  - Row address: A0 to A13
  - Column address: A0 to A9
- Eight internal banks for concurrent operation
- Interface: SSTL\_15
- Burst length (BL): 8 and 4 with Burst Chop (BC)
- Burst type (BT):
  - Sequential (8, 4 with BC)
  - Interleave (8, 4 with BC)
- /CAS Latency (CL): 5, 6, 7, 8, 9, 10, 11, 13, 14
- /CAS Write Latency (CWL): 5, 6, 7, 8, 9, 10
- Precharge: auto precharge option for each burst access
- Driver strength: RZQ/7, RZQ/6 (RZQ = 240Ω)
- Refresh: auto-refresh, self-refresh
- Refresh cycles
  - Average refresh period
    - 7.8μs at 0°C ≤ TC ≤ +85°C
    - 3.9μs at +85°C < TC ≤ +95°C
- Operating case temperature range
  - TC = 0°C to +95°C

#### Features

- Double-data-rate architecture: two data transfers per clock cycle
- The high-speed data transfer is realized by the 8 bits prefetch pipelined architecture
- Bi-directional differential data strobe (DQS and /DQS) is transmitted/received with data for capturing data at the receiver
- DQS is edge-aligned with data for READs; center-aligned with data for WRITEs
- Differential clock inputs (CK and /CK)
- DLL aligns DQ and DQS transitions with CK transitions
- Commands entered on each positive CK edge; data and data mask referenced to both edges of DQS
- Data mask (DM) for write data
- Posted /CAS by programmable additive latency for better command and data bus efficiency
- On-Die Termination (ODT) for better signal quality
  - Synchronous ODT
  - Dynamic ODT
  - Asynchronous ODT
- Multi Purpose Register (MPR) for pre-defined pattern read out
- ZQ calibration for DQ drive and ODT
- /RESET pin for Power-up sequence and reset function
- SRT range:
  - Normal/extended
- Programmable Output driver impedance control
- Seamless BL4 access with bank-grouping
  - Applied only for DDR3-1333 and 1600

### Ordering Information

Part number	Die revision	Organization (words × bits)	Internal banks	JEDEC speed bin (CL-tRCD-tRP)	Package
EDJ2108DEBG-MU-F	E	256M × 8	8	DDR3-2133 (14-14-14)	78-ball FBGA
EDJ2108DEBG-JS-F				DDR3-1866 (13-13-13)	
EDJ2108DEBG-GN-F				DDR3-1600 (11-11-11)	
EDJ2108DEBG-DJ-F				DDR3-1333 (9-9-9)	
EDJ2116DEBG-MU-F	E	128M × 16	8	DDR3-2133 (14-14-14)	96-ball FBGA
EDJ2116DEBG-JS-F				DDR3-1866 (13-13-13)	
EDJ2116DEBG-GN-F				DDR3-1600 (11-11-11)	
EDJ2116DEBG-DJ-F				DDR3-1333 (9-9-9)	

### Part Number

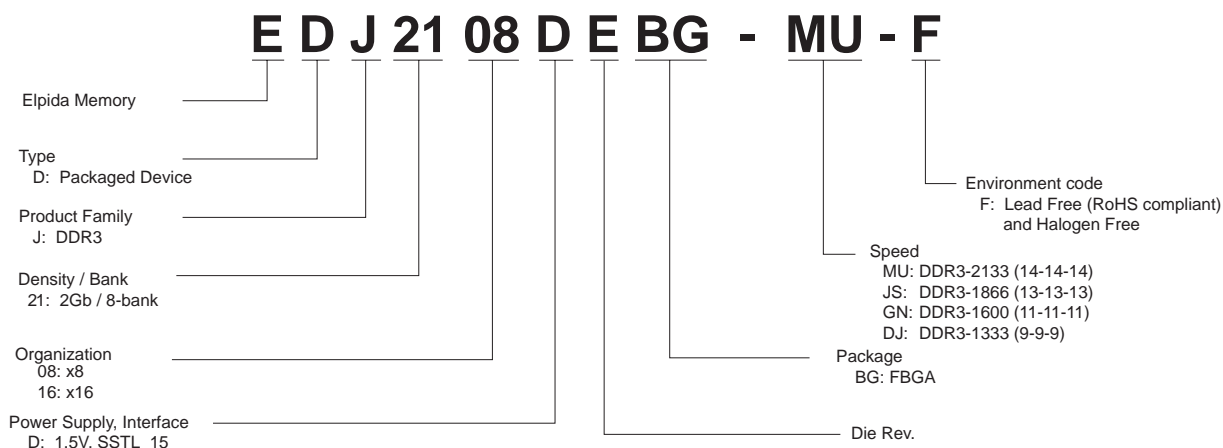

### Operating Frequency

Speed Grade	Frequency (Mbps)									speed bin (CL-tRCD-tRP)
	CL5	CL6	CL7	CL8	CL9	CL10	CL11	CL13	CL14	
-MU		800	1066	1066	1333	1333	1600	1866	2133	DDR3-2133 (14-14-14)
-JS	667	800	1066	1066	1333	1333	1600	1866		DDR3-1866 (13-13-13)
-GN	667	800	1066	1066	1333	1333	1600			DDR3-1600 (11-11-11)
-DJ	667	800	1066	1066	1333	1333				DDR3-1333 (9-9-9)

### Detailed Information

For detailed electrical specification and further information, please refer to the DDR3 SDRAM General Functionality and Electrical Condition data sheet (E1926E) and Addendum data sheet (E1928E).

## Pin Configurations

### Pin Configurations (×8 configuration)

/xxx indicates active low signal.

78-ball FBGA

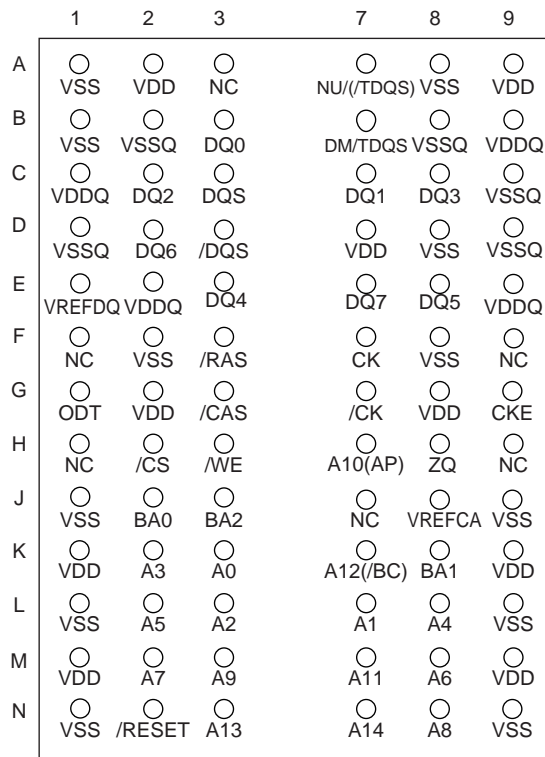

(Top view)

Pin name	Function	Pin name	Function
A0 to A14*3	Address inputs A10(AP): Auto precharge A12(/BC): Burst chop	/RESET*3	Active low asynchronous reset
BA0 to BA2*3	Bank select	VDD	Supply voltage for internal circuit
DQ0 to DQ7	Data input/output	VSS	Ground for internal circuit
DQS, /DQS	Differential data strobe	VDDQ	Supply voltage for DQ circuit
TDQS, /TDQS	Termination data strobe	VSSQ	Ground for DQ circuit
/CS*3	Chip select	VREFDQ	Reference voltage for DQ
/RAS, /CAS, /WE*3	Command input	VREFCA	Reference voltage for CA
CKE*3	Clock enable	ZQ	Reference pin for ZQ calibration
CK, /CK	Differential clock input	NC*1	No connection
DM	Write data mask	NU*2	Not usable
ODT*3	ODT control		

- Notes: 1. Not internally connected with die.  
 2. Don't connect. Internally connected.  
 3. Input only pins (address, command, CKE, ODT and /RESET) do not supply termination.

## Pin Configurations (× 16 configuration)

/xxx indicates active low signal.

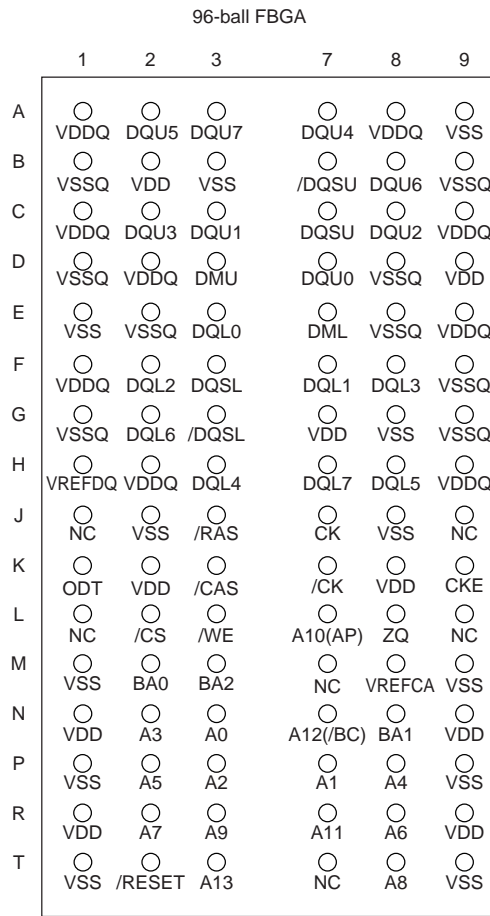

(Top view)

Pin name	Function	Pin name	Function
A0 to A13* <sup>2</sup>	Address inputs A10(AP): Auto precharge A12(BC): Burst chop	/RESET* <sup>2</sup>	Active low asynchronous reset
BA0 to BA2* <sup>2</sup>	Bank select	VDD	Supply voltage for internal circuit
DQU0 to DQU7 DQL0 to DQL7	Data input/output	VSS	Ground for internal circuit
DQSU, /DQSU DQSL, /DQSL	Differential data strobe	VDDQ	Supply voltage for DQ circuit
/CS* <sup>2</sup>	Chip select	VSSQ	Ground for DQ circuit
/RAS, /CAS, /WE* <sup>2</sup>	Command input	VREFDQ	Reference voltage for DQ
CKE* <sup>2</sup>	Clock enable	VREFCA	Reference voltage for CA
CK, /CK	Differential clock input	ZQ	Reference pin for ZQ calibration
DMU, DML	Write data mask	NC* <sup>1</sup>	No connection
ODT* <sup>2</sup>	ODT control		

Notes: 1. Not internally connected with die.

2. Input only pins (address, command, CKE, ODT and /RESET) do not supply termination.

**CONTENTS**

Specifications .....	1
Features .....	1
Ordering Information .....	2
Part Number .....	2
Operating Frequency .....	2
Detailed Information .....	2
Pin Configurations .....	3
1. Electrical Conditions .....	6
1.1 Absolute Maximum Ratings .....	6
1.2 Operating Temperature Condition .....	6
1.3 Recommended DC Operating Conditions .....	7
1.4 IDD and IDDQ Measurement Conditions .....	8
2. Electrical Specifications .....	19
2.1 DC Characteristics .....	19
2.2 Pin Capacitance .....	21
2.3 Standard Speed Bins .....	23
3. Package Drawing .....	29
3.1 78-ball FBGA .....	29
3.2 96-ball FBGA .....	30
4. Recommended Soldering Conditions .....	31

## 1. Electrical Conditions

- All voltages are referenced to VSS (GND)
- Execute power-up and Initialization sequence before proper device operation is achieved.

### 1.1 Absolute Maximum Ratings

**Table 1: Absolute Maximum Ratings**

Parameter	Symbol	Rating	Unit	Notes
Power supply voltage	VDD	-0.4 to +1.975	V	1, 3
Power supply voltage for output	VDDQ	-0.4 to +1.975	V	1, 3
Input voltage	VIN	-0.4 to +1.975	V	1
Output voltage	VOUT	-0.4 to +1.975	V	1
Reference voltage	VREFCA	-0.4 to $0.6 \times VDD$	V	3
Reference voltage for DQ	VREFDQ	-0.4 to $0.6 \times VDDQ$	V	3
Storage temperature	Tstg	-55 to +100	°C	1, 2
Power dissipation	PD	1.0	W	1
Short circuit output current	IOUT	50	mA	1

- Notes: 1. Stresses greater than those listed under Absolute Maximum Ratings may cause permanent damage to the device. This is a stress rating only and functional operation of the device at these or any other conditions above those indicated in the operational sections of this specification is not implied. Exposure to absolute maximum rating conditions for extended periods may affect reliability.
2. Storage temperature is the case surface temperature on the center/top side of the DRAM.
3. VDD and VDDQ must be within 300mV of each other at all times; and VREF must be no greater than  $0.6 \times VDDQ$ . When VDD and VDDQ are less than 500mV; VREF may be equal to or less than 300mV.

**Caution: Exposing the device to stress above those listed in Absolute Maximum Ratings could cause permanent damage. The device is not meant to be operated under conditions outside the limits described in the operational section of this specification. Exposure to Absolute Maximum Rating conditions for extended periods may affect device reliability.**

### 1.2 Operating Temperature Condition

**Table 2: Operating Temperature Condition**

Parameter	Symbol	Rating	Unit	Notes
Operating case temperature	TC	0 to +95	°C	1, 2, 3

- Notes: 1. Operating temperature is the case surface temperature on the center/top side of the DRAM.
2. The Normal Temperature Range specifies the temperatures where all DRAM specifications will be supported. During operation, the DRAM case temperature must be maintained between 0°C to +85°C under all operating conditions.
3. Some applications require operation of the DRAM in the Extended Temperature Range between +85°C and +95°C case temperature. Full specifications are guaranteed in this range, but the following additional conditions apply:
- a) Refresh commands must be doubled in frequency, therefore reducing the refresh interval tREFI to 3.9µs. (This double refresh requirement may not apply for some devices.)
- b) If Self-refresh operation is required in the Extended Temperature Range, then it is mandatory to either use the Manual Self-Refresh mode with Extended Temperature Range capability (MR2 bit [A6, A7] = [0, 1]) or enable the optional Auto Self-Refresh mode (MR2 bit [A6, A7] = [1, 0]).

### 1.3 Recommended DC Operating Conditions

**Table 3: Recommended DC Operating Conditions (TC = 0°C to +85°C, VDD, VDDQ = 1.5V ± 0.075V)**

Parameter	Symbol	min	typ	max	Unit	Notes
Supply voltage	VDD	1.425	1.5	1.575	V	1, 2
Supply voltage for DQ	VDDQ	1.425	1.5	1.575	V	1, 2

Notes: 1. Under all conditions VDDQ must be less than or equal to VDD.

2. VDDQ tracks with VDD. AC parameters are measured with VDD and VDDQ tied together.

## 1.4 IDD and IDDQ Measurement Conditions

In this chapter, IDD and IDDQ measurement conditions such as test load and patterns are defined.

The figure Measurement Setup and Test Load for IDD and IDDQ Measurements shows the setup and test load for IDD and IDDQ measurements.

- IDD currents (such as IDD0, IDD1, IDD2N, IDD2NT, IDD2P0, IDD2P1, IDD2Q, IDD3N, IDD3P, IDD4R, IDD4W, IDD5B, IDD6, IDD6ET, IDD6TC and IDD7) are measured as time-averaged currents with all VDD balls of the DDR3 SDRAM under test tied together. Any IDDQ current is not included in IDD currents.
- IDDQ currents (such as IDDQ2NT and IDDQ4R) are measured as time-averaged currents with all VDDQ balls of the DDR3 SDRAM under test tied together. Any IDD current is not included in IDDQ currents.

Note:IDDQ values cannot be directly used to calculate I/O power of the DDR3 SDRAM. They can be used to support correlation of simulated I/O power to actual I/O power as outlined in correlation from simulated channel I/O power to actual channel I/O power supported by IDDQ measurement.

For IDD and IDDQ measurements, the following definitions apply:

- L and 0:  $V_{IN} \leq V_{IL(AC)max}$
  - H and 1:  $V_{IN} \geq V_{IH(AC)min}$
  - MID-LEVEL: defined as inputs are  $V_{REF} = V_{DDQ} / 2$
  - FLOATING: don't care or floating around  $V_{REF}$ .
  - Timings used for IDD and IDDQ measurement-loop patterns are provided in Timings used for IDD and IDDQ Measurement-Loop Patterns table.
  - Basic IDD and IDDQ measurement conditions are described in Basic IDD and IDDQ Measurement Conditions table.
- Note:The IDD and IDDQ measurement-loop patterns need to be executed at least one time before actual IDD or IDDQ measurement is started.
- Detailed IDD and IDDQ measurement-loop patterns are described in IDD0 Measurement-Loop Pattern table through IDD7 Measurement-Loop Pattern table.
  - IDD Measurements are done after properly initializing the DDR3 SDRAM. This includes but is not limited to setting.
    - RON = RZQ/7 (34Ω in MR1);
    - Qoff = 0B (Output Buffer enabled in MR1);
    - RTT\_Nom = RZQ/6 (40Ω in MR1);
    - RTT\_WR = RZQ/2 (120Ω in MR2);
    - TDQS Feature disabled in MR1
  - Define D = {/CS, /RAS, /CAS, /WE} : = {H, L, L, L}
  - Define /D = {/CS, /RAS, /CAS, /WE} : = {H, H, H, H}

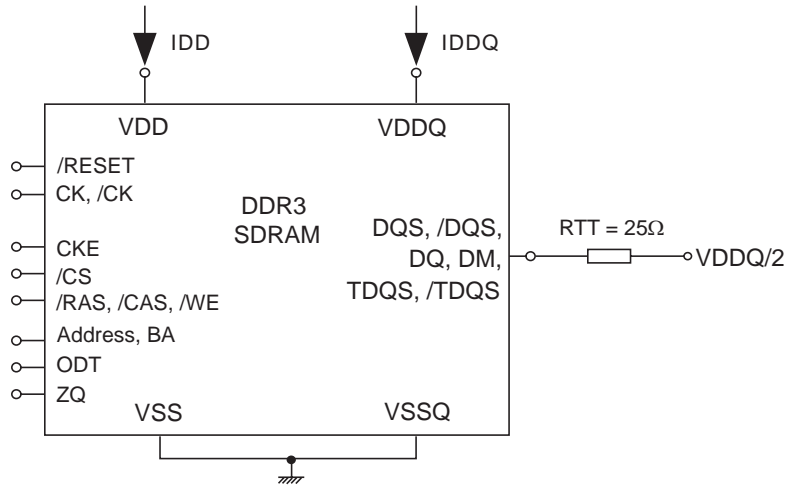

Figure 1: Measurement Setup and Test Load for IDD and IDDQ Measurements

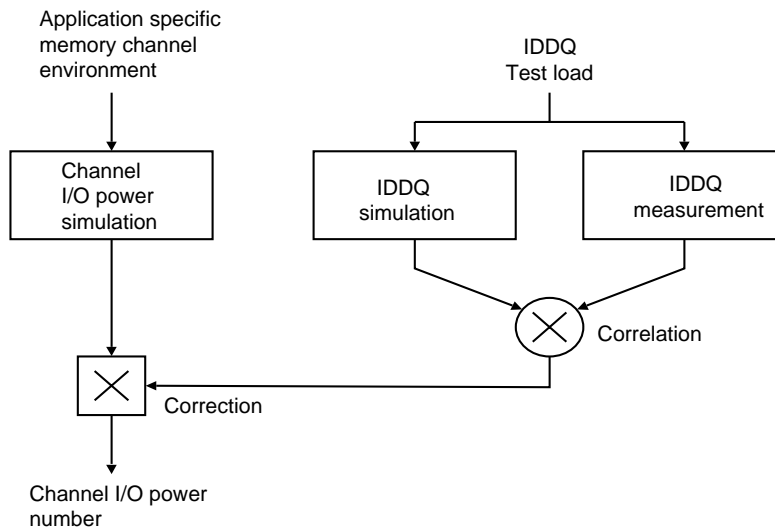

Figure 2: Correlation from Simulated Channel I/O Power to Actual Channel I/O Power Supported by IDDQ Measurement

## 1.4.1 Timings Used for IDD and IDDQ Measurement-Loop Patterns

Table 4: Timings Used for IDD and IDDQ Measurement-Loop Patterns

Parameter	DDR3-800	DDR3-1066	DDR3-1333	DDR3-1600	Unit
	6-6-6	7-7-7	9-9-9	11-11-11	
CL	6	7	9	11	nCK
tCK(min)	2.5	1.875	1.5	1.25	ns
nRCD(min)	6	7	9	11	nCK
nRC(min)	21	27	33	39	nCK
nRAS(min)	15	20	24	28	nCK
nRP(min)	6	7	9	11	nCK
nFAW (1KB)	16	20	20	24	nCK
nFAW (2KB, 4KB)	20	27	30	32	nCK
nRRD (1KB)	4	4	4	5	nCK
nRRD (2KB, 4KB)	4	6	5	6	nCK
nRFC (1Gb)	44	59	74	88	nCK
nRFC (2Gb)	64	86	107	128	nCK
nRFC (4Gb)	104	139	174	208	nCK

Parameter	DDR3-1866	DDR3-2133	Unit
	13-13-13	14-14-14	
CL	13	14	nCK
tCK(min)	1.071	0.938	ns
nRCD(min)	13	14	nCK
nRC(min)	45	50	nCK
nRAS(min)	32	36	nCK
nRP(min)	13	14	nCK
nFAW (1KB)	26	27	nCK
nFAW (2KB, 4KB)	33	38	nCK
nRRD (1KB)	5	6	nCK
nRRD (2KB, 4KB)	6	7	nCK
nRFC (1Gb)	103	118	nCK
nRFC (2Gb)	150	172	nCK
nRFC (4Gb)	243	279	nCK

## 1.4.2 Basic IDD and IDDQ Measurement Conditions

Table 5: Basic IDD and IDDQ Measurement Conditions

Parameter	Symbol	Description
Operating one bank active precharge current	IDD0	CKE: H; External clock: on; tCK, nRC, nRAS, CL: see Table 4; BL: 8*1; AL: 0; /CS: H between ACT and PRE; Command, address, bank address inputs: partially toggling according to Table 6; Data I/O: MID-LEVEL; DM: stable at 0; Bank activity: cycling with one bank active at a time: 0,0,1,1,2,2,... (see Table 6); Output buffer and RTT: enabled in MR*2; ODT signal: stable at 0; Pattern details: see Table 6
Operating one bank active-read-precharge current	IDD1	CKE: H; External clock: On; tCK, nRC, nRAS, nRCD, CL: see Table 4; BL: 8*1, *6; AL: 0; /CS: H between ACT, RD and PRE; Command, address, bank address inputs, data I/O: partially toggling according to Table 7; DM: stable at 0; Bank activity: cycling with one bank active at a time: 0,0,1,1,2,2,... (see Table 7); Output buffer and RTT: enabled in MR*2; ODT Signal: stable at 0; Pattern details: see Table 7
Precharge standby current	IDD2N	CKE: H; External clock: on; tCK, CL: see Table 4 BL: 8*1; AL: 0; /CS: stable at 1; Command, address, bank address Inputs: partially toggling according to Table 8; data I/O: MID-LEVEL; DM: stable at 0; bank activity: all banks closed; output buffer and RTT: enabled in mode registers*2; ODT signal: stable at 0; pattern details: see Table 8
Precharge standby ODT current	IDD2NT	CKE: H; External clock: on; tCK, CL: see Table 4; BL: 8*1; AL: 0; /CS: stable at 1; Command, address, bank address Inputs: partially toggling according to Table 9; data I/O: MID-LEVEL; DM: stable at 0; bank activity: all banks closed; output buffer and RTT: enabled in MR*2; ODT signal: toggling according to Table 9; pattern details: see Table 9
Precharge standby ODT IDDQ current	IDDQ2NT	Same definition like for IDD2NT, however measuring IDDQ current instead of IDD current
Precharge power-down current slow exit	IDD2P0	CKE: L; External clock: on; tCK, CL: see Table 4; BL: 8*1; AL: 0; /CS: stable at 1; Command, address, bank address inputs: stable at 0; data I/O: MID-LEVEL; DM: stable at 0; bank activity: all banks closed; output buffer and RTT: EMR*2; ODT signal: stable at 0; precharge power down mode: slow exit*3
Precharge power-down current fast exit	IDD2P1	CKE: L; External clock: on; tCK, CL: see Table 4; BL: 8*1; AL: 0; /CS: stable at 1; Command, address, bank address Inputs: stable at 0; data I/O: MID-LEVEL; DM: stable at 0; bank activity: all banks closed; output buffer and RTT: enabled in MR*2; ODT signal: stable at 0; precharge power down mode: fast exit*3
Precharge quiet standby current	IDD2Q	CKE: H; External clock: On; tCK, CL: see Table 4; BL: 8*1; AL: 0; /CS: stable at 1; Command, address, bank address Inputs: stable at 0; data I/O: MID-LEVEL; DM: stable at 0; bank activity: all banks closed; output buffer and RTT: enabled in MR*2; ODT signal: stable at 0
Active standby current	IDD3N	CKE: H; External clock: on; tCK, CL: see Table 4; BL: 8*1; AL: 0; /CS: stable at 1; Command, address, bank address Inputs: partially toggling according to Table 8; data I/O: MID-LEVEL; DM: stable at 0; bank activity: all banks open; output buffer and RTT: enabled in MR*2; ODT signal: stable at 0; pattern details: see Table 8
Active power-down current	IDD3P	CKE: L; External clock: on; tCK, CL: see Table 4; BL: 8*1; AL: 0; /CS: stable at 1; Command, address, bank address inputs: stable at 0; data I/O: MID-LEVEL; DM: stable at 0; bank activity: all banks open; output buffer and RTT: enabled in MR*2; ODT signal: stable at 0
Operating burst read current	IDD4R	CKE: H; External clock: on; tCK, CL: see Table 4; BL: 8*1, *6; AL: 0; /CS: H between RD; Command, address, bank address Inputs: partially toggling according to Table 10; data I/O: seamless read data burst with different data between one burst and the next one according to Table 10; DM: stable at 0; bank activity: all banks open, RD commands cycling through banks: 0,0,1,1,2,2,... (see Table 10); Output buffer and RTT: enabled in MR*2; ODT signal: stable at 0; pattern details: see Table 10
Operating burst read IDDQ current	IDDQ4R	Same definition like for IDD4R, however measuring IDDQ current instead of IDD current

Table 5: Basic IDD and IDDQ Measurement Conditions (cont'd)

Parameter	Symbol	Description
Operating burst write current	IDD4W	CKE: H; External clock: on; tCK, CL: see Table 4; BL: 8* <sup>1</sup> ; AL: 0; /CS: H between WR; command, address, bank address inputs: partially toggling according to Table 11; data I/O: seamless write data burst with different data between one burst and the next one according to IDD4W Measurement-Loop Pattern table; DM: stable at 0; bank activity: all banks open, WR commands cycling through banks: 0,0,1,1,2,2,.. (see Table 11); Output buffer and RTT: enabled in MR* <sup>2</sup> ; ODT signal: stable at H; pattern details: see Table 11
Burst refresh current	IDD5B	CKE: H; External clock: on; tCK, CL, nRFC: see Table 4; BL: 8* <sup>1</sup> ; AL: 0; /CS: H between REF; Command, address, bank address Inputs: partially toggling according to Table 12; data I/O: MID-LEVEL; DM: stable at 0; bank activity: REF command every nRFC (Table 12); output buffer and RTT: enabled in MR* <sup>2</sup> ; ODT signal: stable at 0; pattern details: see Table 12
Self-refresh current: normal temperature range	IDD6	TC: 0 to 85°C; ASR: disabled* <sup>4</sup> ; SRT: Normal* <sup>5</sup> ; CKE: L; External clock: off; CK and /CK: L; CL: see Table 4; BL: 8* <sup>1</sup> ; AL: 0; /CS, command, address, bank address, data I/O: MID-LEVEL; DM: stable at 0; bank activity: Self-refresh operation; output buffer and RTT: enabled in MR* <sup>2</sup> ; ODT signal: MID-LEVEL
Self-refresh current: extended temperature range	IDD6ET	TC: 0 to 95°C; ASR: Disabled* <sup>4</sup> ; SRT: Extended* <sup>5</sup> ; CKE: L; External clock: off; CK and /CK: L; CL: Table 4; BL: 8* <sup>1</sup> ; AL: 0; /CS, command, address, bank address, data I/O: MID-LEVEL; DM: stable at 0; bank activity: Extended temperature self-refresh operation; output buffer and RTT: enabled in MR* <sup>2</sup> ; ODT signal: MID-LEVEL
Auto self-refresh current (Optional)	IDD6TC	TC: 0 to 95°C; ASR: Enabled* <sup>4</sup> ; SRT: Normal* <sup>5</sup> ; CKE: L; External clock: off; CK and /CK: L; CL: Table 4; BL: 8* <sup>1</sup> ; AL: 0; /CS, command, address, bank address, data I/O: MID-LEVEL; DM: stable at 0; bank activity: Auto self-refresh operation; output buffer and RTT: enabled in MR* <sup>2</sup> ; ODT signal: MID-LEVEL
Operating bank interleave read current	IDD7	CKE: H; External clock: on; tCK, nRC, nRAS, nRCD, nRRD, nFAW, CL: see Table 4; BL: 8* <sup>1</sup> , * <sup>6</sup> ; AL: CL-1; /CS: H between ACT and RDA; Command, address, bank address Inputs: partially toggling according to Table 13; data I/O: read data bursts with different data between one burst and the next one according to Table 13; DM: stable at 0; bank activity: two times interleaved cycling through banks (0, 1, ...7) with different addressing, see Table 13; output buffer and RTT: enabled in MR* <sup>2</sup> ; ODT signal: stable at 0; pattern details: see Table 13
RESET low current	IDD8	/RESET: low; External clock: off; CK and /CK: low; CKE: FLOATING; /CS, command, address, bank address, Data IO: FLOATING; ODT signal: FLOATING RESET low current reading is valid once power is stable and /RESET has been low for at least 1ms.

- Notes: 1. Burst Length: BL8 fixed by MRS: MR0 bits [1,0] = [0,0].  
2. MR: Mode Register  
Output buffer enable: set MR1 bit A12 = 1 and MR1 bits [5, 1] = [0,1];  
RTT\_Nom enable: set MR1 bits [9, 6, 2] = [0, 1, 1]; RTT\_WR enable: set MR2 bits [10, 9] = [1,0].  
3. Precharge power down mode: set MR0 bit A12= 0 for Slow Exit or MR0 bit A12 = 1 for fast exit.  
4. Auto self-refresh (ASR): set MR2 bit A6 = 0 to disable or 1 to enable feature.  
5. Self-refresh temperature range (SRT): set MR0 bit A7= 0 for normal or 1 for extended temperature range.  
6. Read burst type: nibble sequential, set MR0 bit A3 = 0

Table 6: IDD0 Measurement-Loop Pattern

CK, /CK	CKE	Sub -Loop	Cycle number	Com- mand	/CS	/RAS	/CAS	/WE	ODT	BA* <sup>3</sup>	A11 -Am	A10	A7 -A9	A3 -A6	A0 -A2	Data* <sup>2</sup>	
			0	ACT	0	0	1	1	0	0	0	0	0	0	0		
			1, 2	D, D	1	0	0	0	0	0	0	0	0	0	0		
			3, 4	/D, /D	1	1	1	1	0	0	0	0	0	0	0		
			...	Repeat pattern 1...4 until nRAS – 1, truncate if necessary													
			nRAS	PRE	0	0	1	0	0	0	0	0	0	0	0		
			...	Repeat pattern 1...4 until nRC – 1, truncate if necessary													
		0	1 × nRC + 0	ACT	0	0	1	1	0	0	0	0	0	F	0		
			1 × nRC + 1, 2	D, D	1	0	0	0	0	0	0	0	0	F	0		
Toggling	Static H		1 × nRC + 3, 4	/D, /D	1	1	1	1	0	0	0	0	0	F	0		
			...	Repeat pattern nRC + 1,...,4 until 1 × nRC + nRAS – 1, truncate if necessary													
			1 × nRC + nRAS	PRE	0	0	1	0	0	0	0	0	0	F	0		
			...	Repeat nRC + 1,...,4 until 2 × nRC – 1, truncate if necessary													
		1	2 × nRC	Repeat Sub-Loop 0, use BA= 1 instead													
		2	4 × nRC	Repeat Sub-Loop 0, use BA= 2 instead													
		3	6 × nRC	Repeat Sub-Loop 0, use BA= 3 instead													
		4	8 × nRC	Repeat Sub-Loop 0, use BA= 4 instead													
		5	10 × nRC	Repeat Sub-Loop 0, use BA= 5 instead													
		6	12 × nRC	Repeat Sub-Loop 0, use BA= 6 instead													
		7	14 × nRC	Repeat Sub-Loop 0, use BA= 7 instead													

- Notes: 1. DM must be driven low all the time. DQS, /DQS are MID-LEVEL.  
2. DQ signals are MID-LEVEL.  
3. BA: BA0 to BA2.  
4. Am: m means Most Significant Bit (MSB) of Row address.

Table 7: IDD1 Measurement-Loop Pattern

CK, /CK	CKE	Sub -Loop	Cycle number	Com- mand	/CS	/RAS	/CAS	/WE	ODT	BA* <sup>3</sup>	A11 -Am	A10	A7 -A9	A3 -A6	A0 -A2	Data* <sup>2</sup>
			0	ACT	0	0	1	1	0	0	0	0	0	0	0	—
			1, 2	D, D	1	0	0	0	0	0	0	0	0	0	0	—
			3, 4	/D, /D	1	1	1	1	0	0	0	0	0	0	0	—
			...	Repeat pattern 1...4 until nRCD – 1, truncate if necessary												
			nRCD	RD	0	1	0	1	0	0	0	0	0	0	0	00000000
			...	Repeat pattern 1...4 until nRAS – 1, truncate if necessary												
			nRAS	PRE	0	0	1	0	0	0	0	0	0	0	0	—
			...	Repeat pattern 1...4 until nRC – 1, truncate if necessary												
		0	1 × nRC + 0	ACT	0	0	1	1	0	0	0	0	0	F	0	—
			1 × nRC + 1, 2	D, D	1	0	0	0	0	0	0	0	0	F	0	—
			1 × nRC + 3, 4	/D, /D	1	1	1	1	0	0	0	0	0	F	0	—
0	Static H		...	Repeat pattern nRC + 1,..., 4 until nRC + nRCD – 1, truncate if necessary												
			1 × nRC + nRCD	RD	0	1	0	1	0	0	0	0	0	F	0	00110011
			...	Repeat pattern nRC + 1,..., 4 until nRC + nRAS – 1, truncate if necessary												
			1 × nRC + nRAS	PRE	0	0	1	0	0	0	0	0	0	F	0	—
			...	Repeat pattern nRC + 1,..., 4 until 2 × nRC – 1, truncate if necessary												
		1	2 × nRC	Repeat Sub-Loop 0, use BA= 1 instead												
		2	4 × nRC	Repeat Sub-Loop 0, use BA= 2 instead												
		3	6 × nRC	Repeat Sub-Loop 0, use BA= 3 instead												
		4	8 × nRC	Repeat Sub-Loop 0, use BA= 4 instead												
		5	10 × nRC	Repeat Sub-Loop 0, use BA= 5 instead												
		6	12 × nRC	Repeat Sub-Loop 0, use BA= 6 instead												
		7	14 × nRC	Repeat Sub-Loop 0, use BA= 7 instead												

- Notes: 1. DM must be driven low all the time. DQS, /DQS are used according to read commands, otherwise MID-LEVEL.  
2. Burst sequence driven on each DQ signal by read command. Outside burst operation, DQ signals are MID-LEVEL.  
3. BA: BA0 to BA2.  
4. Am: m means Most Significant Bit (MSB) of Row address.

Table 8: IDD2N and IDD3N Measurement-Loop Pattern

CK, /CK	CKE	Sub -Loop	Cycle number	Com- mand	/CS	/RAS	/CAS	/WE	ODT	BA* <sup>3</sup>	A11 -Am	A10	A7 -A9	A3 -A6	A0 -A2	Data* <sup>2</sup>
			0	D	1	0	0	0	0	0	0	0	0	0	0	0
		0	1	D	1	0	0	0	0	0	0	0	0	0	0	0
			2	/D	1	1	1	1	0	0	0	0	0	F	0	
			3	/D	1	1	1	1	0	0	0	0	0	F	0	
		1	4 to 7	Repeat Sub-Loop 0, use BA= 1 instead												
Toggling	Static H	2	8 to 11	Repeat Sub-Loop 0, use BA= 2 instead												
		3	12 to 15	Repeat Sub-Loop 0, use BA= 3 instead												
		4	16 to 19	Repeat Sub-Loop 0, use BA= 4 instead												
		5	20 to 23	Repeat Sub-Loop 0, use BA= 5 instead												
		6	24 to 27	Repeat Sub-Loop 0, use BA= 6 instead												
		7	28 to 31	Repeat Sub-Loop 0, use BA= 7 instead												

- Notes: 1. DM must be driven low all the time. DQS, /DQS are MID-LEVEL.  
 2. DQ signals are MID-LEVEL.  
 3. BA: BA0 to BA2.  
 4. Am: m means Most Significant Bit (MSB) of Row address.

Table 9: IDD2NT and IDDQ2NT Measurement-Loop Pattern

CK, /CK	CKE	Sub -Loop	Cycle number	Com- mand	/CS	/RAS	/CAS	/WE	ODT	BA* <sup>3</sup>	A11 -Am	A10	A7 -A9	A3 -A6	A0 -A2	Data* <sup>2</sup>
			0	D	1	0	0	0	0	0	0	0	0	0	0	0
		0	1	D	1	0	0	0	0	0	0	0	0	0	0	0
			2	/D	1	1	1	1	0	0	0	0	0	F	0	
			3	/D	1	1	1	1	0	0	0	0	0	F	0	
		1	4 to 7	Repeat Sub-Loop 0, but ODT = 0 and BA= 1												
Toggling	Static H	2	8 to 11	Repeat Sub-Loop 0, but ODT = 1 and BA= 2												
		3	12 to 15	Repeat Sub-Loop 0, but ODT = 1 and BA= 3												
		4	16 to 19	Repeat Sub-Loop 0, but ODT = 0 and BA= 4												
		5	20 to 23	Repeat Sub-Loop 0, but ODT = 0 and BA= 5												
		6	24 to 27	Repeat Sub-Loop 0, but ODT = 1 and BA= 6												
		7	28 to 31	Repeat Sub-Loop 0, but ODT = 1 and BA= 7												

- Notes: 1. DM must be driven low all the time. DQS, /DQS are MID-LEVEL.  
 2. DQ signals are MID-LEVEL.  
 3. BA: BA0 to BA2.  
 4. Am: m means Most Significant Bit (MSB) of Row address.

Table 10: IDD4R and IDDQ4R Measurement-Loop Pattern

CK, /CK	CKE	Sub -Loop	Cycle number	Com- mand	/CS	/RAS	/CAS	/WE	ODT	BA* <sup>3</sup>	A11 -Am	A10	A7 -A9	A3 -A6	A0 -A2	Data* <sup>2</sup>
			0	RD	0	1	0	1	0	0	0	0	0	0	0	00000000
			1	D	1	0	0	0	0	0	0	0	0	0	0	—
		0	2,3	/D, /D	1	1	1	1	0	0	0	0	0	0	0	—
			4	RD	0	1	0	1	0	0	0	0	0	F	0	00110011
			5	D	1	0	0	0	0	0	0	0	0	F	0	—
			6,7	/D, /D	1	1	1	1	0	0	0	0	0	F	0	—
Toggling	Static H	1	8 to 15	Repeat Sub-Loop 0, but BA= 1												
		2	16 to 23	Repeat Sub-Loop 0, but BA= 2												
		3	24 to 31	Repeat Sub-Loop 0, but BA= 3												
		4	32 to 39	Repeat Sub-Loop 0, but BA= 4												
		5	40 to 47	Repeat Sub-Loop 0, but BA= 5												
		6	48 to 55	Repeat Sub-Loop 0, but BA= 6												
		7	56 to 63	Repeat Sub-Loop 0, but BA= 7												

- Notes: 1. DM must be driven low all the time. DQS, /DQS are used according to read commands, otherwise MID-LEVEL.  
 2. Burst sequence driven on each DQ signal by read command. Outside burst operation, DQ signals are MID-LEVEL.  
 3. BA: BA0 to BA2.  
 4. Am: m means Most Significant Bit (MSB) of Row address.

**Table 11: IDD4W Measurement-Loop Pattern**

CK, /CK	CKE	Sub -Loop	Cycle number	Com- mand	/CS	/RAS	/CAS	/WE	ODT	BA* <sup>3</sup>	A11 -Am	A10	A7 -A9	A3 -A6	A0 -A2	Data* <sup>2</sup>
			0	WR	0	1	0	0	1	0	0	0	0	0	0	00000000
			1	D	1	0	0	0	1	0	0	0	0	0	0	—
		0	2,3	/D, /D	1	1	1	1	1	0	0	0	0	0	0	—
			4	WR	0	1	0	0	1	0	0	0	0	F	0	00110011
			5	D	1	0	0	0	1	0	0	0	0	F	0	—
			6,7	/D, /D	1	1	1	1	1	0	0	0	0	F	0	—
Toggling	Static H	1	8 to 15	Repeat Sub-Loop 0, but BA= 1												
		2	16 to 23	Repeat Sub-Loop 0, but BA= 2												
		3	24 to 31	Repeat Sub-Loop 0, but BA= 3												
		4	32 to 39	Repeat Sub-Loop 0, but BA= 4												
		5	40 to 47	Repeat Sub-Loop 0, but BA= 5												
		6	48 to 55	Repeat Sub-Loop 0, but BA= 6												
		7	56 to 63	Repeat Sub-Loop 0, but BA= 7												

- Notes: 1. DM must be driven low all the time. DQS, /DQS are used according to write commands, otherwise MID-LEVEL.  
 2. Burst sequence driven on each DQ signal by write command. Outside burst operation, DQ signals are MID-LEVEL.  
 3. BA: BA0 to BA2.  
 4. Am: m means Most Significant Bit (MSB) of Row address.

**Table 12: IDD5B Measurement-Loop Pattern**

CK, /CK	CKE	Sub -Loop	Cycle number	Com- mand	/CS	/RAS	/CAS	/WE	ODT	BA* <sup>3</sup>	A11 -Am	A10	A7 -A9	A3 -A6	A0 -A2	Data* <sup>2</sup>
			0	REF	0	0	0	1	0	0	0	0	0	0	0	—
		0	1, 2	D	1	0	0	0	0	0	0	0	0	0	0	—
			3,4	/D, /D	1	1	1	1	0	0	0	0	0	F	0	—
			5 to 8	Repeat cycles 1...4, but BA= 1												
			9 to 12	Repeat cycles 1...4, but BA= 2												
			13 to 16	Repeat cycles 1...4, but BA= 3												
Toggling	Static H	1	17 to 20	Repeat cycles 1...4, but BA= 4												
			21 to 24	Repeat cycles 1...4, but BA= 5												
			25 to 28	Repeat cycles 1...4, but BA= 6												
			29 to 32	Repeat cycles 1...4, but BA= 7												
		2	33 to nRFC – 1	Repeat Sub-Loop 1, until nRFC – 1. Truncate, if necessary.												

- Notes: 1. DM must be driven low all the time. DQS, /DQS are MID-LEVEL.  
 2. DQ signals are MID-LEVEL.  
 3. BA: BA0 to BA2.  
 4. Am: m means Most Significant Bit (MSB) of Row address.

Table 13: IDD7 Measurement-Loop Pattern

CK, /CK	CKE	Sub -Loop	Cycle number	Com- mand	/CS	/RAS	/CAS	/WE	ODT	BA <sup>*3</sup>	A11 -Am	A10	A7 -A9	A3 -A6	A0 -A2	Data <sup>*2</sup>	
			0	ACT	0	0	1	1	0	0	0	0	0	0	0	—	
			1	RDA	0	1	0	1	0	0	0	1	0	0	0	00000000	
			2	D	1	0	0	0	0	0	0	0	0	0	0	—	
			...	Repeat above D Command until nRRD – 1													
			nRRD	ACT	0	0	1	1	0	1	0	0	0	F	0	—	
			nRRD + 1	RDA	0	1	0	1	0	1	0	1	0	F	0	00110011	
			nRRD + 2	D	1	0	0	0	0	1	0	0	0	F	0	—	
			...	Repeat above D Command until 2 × nRRD – 1													
			2 × nRRD	Repeat Sub-Loop 0, but BA= 2													
			3 × nRRD	Repeat Sub-Loop 1, but BA= 3													
			4 × nRRD	D	1	0	0	0	0	3	0	0	0	F	0	—	
			...	Assert and repeat above D Command until nFAW – 1, if necessary													
			nFAW	Repeat Sub-Loop 0, but BA= 4													
			nFAW + nRRD	Repeat Sub-Loop 1, but BA= 5													
			nFAW + 2 × nRRD	Repeat Sub-Loop 0, but BA= 6													
			nFAW + 3 × nRRD	Repeat Sub-Loop 1, but BA= 7													
			nFAW + 4 × nRRD	D	1	0	0	0	0	7	0	0	0	F	0	—	
			...	Assert and repeat above D Command until 2 × nFAW – 1, if necessary													
			2 × nFAW + 0	ACT	0	0	1	1	0	0	0	0	0	F	0	—	
0	Static H		2 × nFAW + 1	RDA	0	1	0	1	0	0	0	1	0	F	0	00110011	
			2 × nFAW + 2	D	1	0	0	0	0	0	0	0	0	F	0	—	
			...	Repeat above D Command until 2 × nFAW + nRRD – 1													
			2 × nFAW + nRRD	ACT	0	0	1	1	0	1	0	0	0	0	0	—	
			2 × nFAW + nRRD + 1	RDA	0	1	0	1	0	1	0	1	0	0	0	00000000	
			2 × nFAW + nRRD + 2	D	1	0	0	0	0	1	0	0	0	0	0	—	
			...	Repeat above D Command until 2 × nFAW + 2 × nRRD – 1													
			2 × nFAW + 2 × nRRD	Repeat Sub-Loop 10, but BA= 2													
			2 × nFAW + 3 × nRRD	Repeat Sub-Loop 11, but BA= 3													
			2 × nFAW + 4 × nRRD	D	1	0	0	0	0	3	0	0	0	0	0	—	
			...	Assert and repeat above D Command until 3 × nFAW – 1, if necessary													
			3 × nFAW	Repeat Sub-Loop 10, but BA= 4													
			3 × nFAW + nRRD	Repeat Sub-Loop 11, but BA= 5													
			3 × nFAW + 2 × nRRD	Repeat Sub-Loop 10, but BA= 6													
			3 × nFAW + 3 × nRRD	Repeat Sub-Loop 11, but BA= 7													
			3 × nFAW + 4 × nRRD	D	1	0	0	0	0	7	0	0	0	0	0	—	
			...	Assert and repeat above D Command until 4 × nFAW – 1, if necessary													

- Notes: 1. DM must be driven low all the time. DQS, /DQS are used according to read commands, otherwise MID-LEVEL.  
2. Burst sequence driven on each DQ signal by read command. Outside burst operation, DQ signals are MID-LEVEL.  
3. BA: BA0 to BA2.  
4. Am: m means Most Significant Bit (MSB) of Row address.

## 2. Electrical Specifications

### 2.1 DC Characteristics

Table 14: DC Characteristics 1 (TC = 0°C to +85°C, VDD, VDDQ = 1.5V ± 0.075V)

Parameter	Symbol	Data rate (Mbps)	Data rate		Unit	Notes
			× 8 max	× 16 max		
Operating current (ACT-PRE)	IDD0	1333	50	60	mA	
		1600	50	65		
		1866	65	75		
		2133	70	80		
Operating current (ACT-RD-PRE)	IDD1	1333	60	75	mA	
		1600	65	80		
		1866	80	100		
		2133	85	105		
Precharge power-down standby current	IDD2P1	1333	18	20	mA	Fast PD Exit
		1600	19	22		
		1866	25	25		
		2133	27	27		
	IDD2P0	1333	12	12	mA	Slow PD Exit
		1600	12	12		
		1866	12	12		
		2133	12	12		
Precharge standby current	IDD2N	1333	30	30	mA	
		1600	32	33		
		1866	40	40		
		2133	43	43		
Precharge standby ODT current	IDD2NT	1333	30	30	mA	
		1600	32	33		
		1866	40	40		
		2133	43	43		
Precharge quiet standby current	IDD2Q	1333	30	30	mA	
		1600	32	33		
		1866	40	40		
		2133	43	43		
Active power-down current (Always fast exit)	IDD3P	1333	22	25	mA	
		1600	23	30		
		1866	30	30		
		2133	32	32		
Active standby current	IDD3N	1333	40	45	mA	
		1600	45	45		
		1866	50	55		
		2133	55	60		
Operating current (Burst read operating)	IDD4R	1333	100	120	mA	
		1600	115	140		
		1866	145	180		
		2133	160	200		
Operating current (Burst write operating)	IDD4W	1333	105	150	mA	
		1600	120	170		
		1866	145	205		
		2133	160	235		
Burst refresh current	IDD5B	1333	170	170	mA	
		1600	170	170		
		1866	185	185		
		2133	190	190		

Table 14: DC Characteristics 1 (TC = 0°C to +85°C, VDD, VDDQ = 1.5V ± 0.075V)(cont'd)

Parameter	Symbol	Data rate (Mbps)	× 8	× 16	Unit	Notes
			max	max		
All bank interleave read current	IDD7	1333	155	180	mA	
		1600	165	200		
		1866	190	250		
		2133	200	260		
RESET low current	IDD8		12	12	mA	

Table 15: Self-Refresh Current (TC = 0°C to +85°C, VDD, VDDQ = 1.5V ± 0.075V)

Parameter	Symbol	max	Unit	Notes
Self-refresh current normal temperature range	IDD6	12	mA	
Self-refresh current extended temperature range	IDD6ET	18	mA	
Auto self-refresh current (Optional)	IDD6TC	—	mA	

## 2.2 Pin Capacitance

**Table 16: Pin Capacitance [DDR3-800 to 1600] (TC = 25°C, VDD, VDDQ = 1.5V ± 0.075V)**

Parameter	Symbol	DDR3-800		DDR3-1066		DDR3-1333		DDR3-1600		Units	Notes
		min	max	min	max	min	max	min	max		
Input/output capacitance	CIO	1.4	3.0	1.4	2.7	1.4	2.5	1.4	2.3	pF	1, 2
Input capacitance, CK and /CK	CCK	0.8	1.6	0.8	1.6	0.8	1.4	0.8	1.4	pF	2
Input capacitance delta, CK and /CK	CDCK	0	0.15	0	0.15	0	0.15	0	0.15	pF	2, 3
Input/output capacitance delta, DQS and /DQS	CDDQS	0	0.2	0	0.2	0	0.15	0	0.15	pF	2, 4
Input capacitance, (control, address, command, input-only pins)	CI	0.75	1.4	0.75	1.35	0.75	1.3	0.75	1.3	pF	2, 5
Input capacitance delta, (All control input-only pins)	CDI_CTRL	-0.5	0.3	-0.5	0.3	-0.4	0.2	-0.4	0.2	pF	2, 6, 7
Input capacitance delta, (All address/command input-only pins)	CDI_ADD_CMD	-0.5	0.5	-0.5	0.5	-0.4	0.4	-0.4	0.4	pF	2, 8, 9
Input/output capacitance delta, DQ,DM, DQS, /DQS, TDQS, /TDQS	CDIO	-0.5	0.3	-0.5	0.3	-0.5	0.3	-0.5	0.3	pF	2, 10
Input/output capacitance of ZQ pin	CZQ	—	3	—	3	—	3	—	3	pF	2, 11

**Table 17: Pin Capacitance [DDR3-1866 to 2133] (TC = 25°C, VDD, VDDQ = 1.5V ± 0.075V)**

Parameter	Symbol	DDR3-1866		DDR3-2133		Units	Notes
		min	max	min	max		
Input/output capacitance	CIO	1.4	2.2	1.4	2.1	pF	1, 2
Input capacitance, CK and /CK	CCK	0.8	1.3	0.8	1.3	pF	2
Input capacitance delta, CK and /CK	CDCK	0	0.15	0	0.15	pF	2, 3
Input/output capacitance delta, DQS and /DQS	CDDQS	0	0.15	0	0.15	pF	2, 4
Input capacitance, (control, address, command, input-only pins)	CI	0.75	1.2	0.75	1.2	pF	2, 5
Input capacitance delta, (All control input-only pins)	CDI_CTRL	-0.4	0.2	-0.4	0.2	pF	2, 6, 7
Input capacitance delta, (All address/command input-only pins)	CDI_ADD_CMD	-0.4	0.4	-0.4	0.4	pF	2, 8, 9
Input/output capacitance delta, DQ,DM, DQS, /DQS, TDQS, /TDQS	CDIO	-0.5	0.3	-0.5	0.3	pF	2, 10
Input/output capacitance of ZQ pin	CZQ	—	3	—	3	pF	2, 11

- Notes:
1. Although the DM, TDQS and /TDQS pins have different functions, the loading matches DQ and DQS.
  2. VDD, VDDQ, VSS, VSSQ applied and all other pins floating (except the pin under test, CKE, /RESET and ODT as necessary). VDD = VDDQ = 1.5V, VBIAS = VDD/2 and ondie termination off.
  3. Absolute value of CCK-C/CK.
  4. Absolute value of CIO(DQS)-CIO(/DQS).
  5. CI applies to ODT, /CS, CKE, A0-A15, BA0-BA2, /RAS, /CAS and /WE.
  6. CDI\_CTRL applies to ODT, /CS and CKE.
  7.  $CDI\_CTRL = CI(CTRL) - 0.5 \times (CI(CK)+CI(/CK))$ .
  8. CDI\_ADD\_CMD applies to A0-A15, BA0-BA2, /RAS, /CAS and /WE.
  9.  $CDI\_ADD\_CMD = CI(ADD\_CMD) - 0.5 \times (CI(CK)+CI(/CK))$ .
  10.  $CDIO = CIO(DQ,DM) - 0.5 \times (CIO(DQS)+CIO(/DQS))$ .
  11. Maximum external load capacitance on ZQ pin: 5pF.

## 2.3 Standard Speed Bins

Table 18: DDR3-800 Speed Bins

Speed Bin		DDR3-800E			
CL-tRCD-tRP		6-6-6			
Symbol	/CAS write latency	min	max	Unit	Notes
tAA		15	20	ns	11
tRCD		15	—	ns	11
tRP		15	—	ns	11
tRC		52.5	—	ns	11
tRAS		37.5	9 × tREFI	ns	10
tCK(avg) @CL=5	CWL = 5	3.0	3.3	ns	1, 2, 3, 12, 13
tCK(avg) @CL=6	CWL = 5	2.5	3.3	ns	1, 2, 3, 12, 13
Supported CL settings			5, 6	nCK	
Supported CWL settings			5	nCK	

Table 19: DDR3-1066 Speed Bins

Speed Bin		DDR3-1066F			
CL-tRCD-tRP		7-7-7			
Symbol	/CAS write latency	min	max	Unit	Notes
tAA		13.125	20	ns	11
tRCD		13.125	—	ns	11
tRP		13.125	—	ns	11
tRC		50.625	—	ns	11
tRAS		37.5	9 × tREFI	ns	10
tCK(avg) @CL=5	CWL = 5	3.0	3.3	ns	1, 2, 3, 5, 12, 13
	CWL = 6	Reserved	Reserved	ns	4
tCK(avg) @CL=6	CWL = 5	2.5	3.3	ns	1, 2, 3, 5, 13
	CWL = 6	Reserved	Reserved	ns	4
tCK(avg) @CL=7	CWL = 5	Reserved	Reserved	ns	4
	CWL = 6	1.875	< 2.5	ns	1, 2, 3, 13
tCK(avg) @CL=8	CWL = 5	Reserved	Reserved	ns	4
	CWL = 6	1.875	< 2.5	ns	1, 2, 3, 13
Supported CL settings			5, 6, 7, 8	nCK	
Supported CWL settings			5, 6	nCK	

Table 20: DDR3-1333 Speed Bins

Speed Bin		DDR3-1333H			
CL-tRCD-tRP		9-9-9			
Symbol	/CAS write latency	min	max	Unit	Notes
tAA		13.5 (13.125)	20	ns	11
tRCD		13.5 (13.125)	—	ns	11
tRP		13.5 (13.125)	—	ns	11
tRC		49.5 (49.125)	—	ns	11
tRAS		36	9 × tREFI	ns	10
tCK(avg) @CL=5	CWL = 5	3.0	3.3	ns	1, 2, 3, 6, 12, 13
	CWL = 6, 7	Reserved	Reserved	ns	4
tCK(avg) @CL=6	CWL = 5	2.5	3.3	ns	1, 2, 3, 6, 13
	CWL = 6	Reserved	Reserved	ns	4
	CWL = 7	Reserved	Reserved	ns	4
tCK(avg) @CL=7	CWL = 5	Reserved	Reserved	ns	4
	CWL = 6	1.875	< 2.5	ns	1, 2, 3, 6, 13
	CWL = 7	Reserved	Reserved	ns	4
tCK(avg) @CL=8	CWL = 5	Reserved	Reserved	ns	4
	CWL = 6	1.875	< 2.5	ns	1, 2, 3, 6, 13
	CWL = 7	Reserved	Reserved	ns	4
tCK(avg) @CL=9	CWL = 5, 6	Reserved	Reserved	ns	4
	CWL = 7	1.5	< 1.875	ns	1, 2, 3, 13
tCK(avg) @CL=10	CWL = 5, 6	Reserved	Reserved	ns	4
	CWL = 7	1.5	< 1.875	ns	1, 2, 3, 13
Supported CL settings		5, 6, 7, 8, 9, 10		nCK	
Supported CWL settings		5, 6, 7		nCK	

Table 21: DDR3-1600 Speed Bins

Speed Bin		DDR3-1600K			
CL-tRCD-tRP		11-11-11			
Symbol	/CAS write latency	min	max	Unit	Notes
tAA		13.75 (13.125)	20	ns	11
tRCD		13.75 (13.125)	—	ns	11
tRP		13.75 (13.125)	—	ns	11
tRC		48.75 (48.125)	—	ns	11
tRAS		35	9 × tREFI	ns	10
tCK(avg) @CL=5	CWL = 5	3.0	3.3	ns	1, 2, 3, 7, 12, 13
	CWL = 6, 7, 8	Reserved	Reserved	ns	4
tCK(avg) @CL=6	CWL = 5	2.5	3.3	ns	1, 2, 3, 7, 13
	CWL = 6	Reserved	Reserved	ns	4
	CWL = 7, 8	Reserved	Reserved	ns	4
tCK(avg) @CL=7	CWL = 5	Reserved	Reserved	ns	4
	CWL = 6	1.875	< 2.5	ns	1, 2, 3, 7, 13
	CWL = 7	Reserved	Reserved	ns	4
	CWL = 8	Reserved	Reserved	ns	4
tCK(avg) @CL=8	CWL = 5	Reserved	Reserved	ns	4
	CWL = 6	1.875	< 2.5	ns	1, 2, 3, 7, 13
	CWL = 7	Reserved	Reserved	ns	4
	CWL = 8	Reserved	Reserved	ns	4
tCK(avg) @CL=9	CWL = 5, 6	Reserved	Reserved	ns	4
	CWL = 7	1.5	< 1.875	ns	1, 2, 3, 7, 13
	CWL = 8	Reserved	Reserved	ns	4
tCK(avg) @CL=10	CWL = 5, 6	Reserved	Reserved	ns	4
	CWL = 7	1.5	< 1.875	ns	1, 2, 3, 7, 13
	CWL = 8	Reserved	Reserved	ns	4
tCK(avg) @CL=11	CWL = 5, 6, 7	Reserved	Reserved	ns	4
	CWL = 8	1.25	< 1.5	ns	1, 2, 3, 13
Supported CL settings		5, 6, 7, 8, 9, 10, 11		nCK	
Supported CWL settings		5, 6, 7, 8		nCK	

Table 22: DDR3-1866 Speed Bins

Speed Bin		DDR3-1866M			
CL-tRCD-tRP		13-13-13			
Symbol	/CAS write latency	min	max	Unit	Notes
tAA		13.91 (13.125)	20.0	ns	11
tRCD		13.91 (13.125)	—	ns	11
tRP		13.91 (13.125)	—	ns	11
tRC		47.91 (47.125)	—	ns	11
tRAS		34.0	9 × tREFI	ns	10
tCK(avg) @CL=5	CWL = 5	3.0	3.3	ns	1, 2, 3, 8, 13
	CWL = 6, 7, 8, 9	Reserved	Reserved	ns	4
tCK(avg) @CL=6	CWL = 5	2.5	3.3	ns	1, 2, 3, 8, 13
	CWL = 6	Reserved	Reserved	ns	4
	CWL = 7, 8, 9	Reserved	Reserved	ns	4
tCK(avg) @CL=7	CWL = 5	Reserved	Reserved	ns	4
	CWL = 6	1.875	2.5	ns	1, 2, 3, 8, 13
	CWL = 7, 8, 9	Reserved	Reserved	ns	4
tCK(avg) @CL=8	CWL = 5	Reserved	Reserved	ns	4
	CWL = 6	1.875	2.5	ns	1, 2, 3, 8, 13
	CWL = 7	Reserved	Reserved	ns	4
	CWL = 8, 9	Reserved	Reserved	ns	4
tCK(avg) @CL=9	CWL = 5, 6	Reserved	Reserved	ns	4
	CWL = 7	1.5	1.875	ns	1, 2, 3, 8, 13
	CWL = 8	Reserved	Reserved	ns	4
	CWL = 9	Reserved	Reserved	ns	4
tCK(avg) @CL=10	CWL = 5, 6	Reserved	Reserved	ns	4
	CWL = 7	1.5	1.875	ns	1, 2, 3, 8, 13
	CWL = 8	Reserved	Reserved	ns	4
tCK(avg) @CL=11	CWL = 5, 6, 7	Reserved	Reserved	ns	4
	CWL = 8	1.25	1.5	ns	1, 2, 3, 8, 13
	CWL = 9	Reserved	Reserved	ns	4
tCK(avg) @CL=12	CWL = 5, 6, 7, 8	Reserved	Reserved	ns	4
	CWL = 9	Reserved	Reserved	ns	4
tCK(avg) @CL=13	CWL = 5, 6, 7, 8	Reserved	Reserved	ns	4
	CWL = 9	1.071	1.25	ns	1, 2, 3, 13
Supported CL settings		5, 6, 7, 8, 9, 10, 11, 13		nCK	
Supported CWL settings		5, 6, 7, 8, 9		nCK	

Table 23: DDR3-2133 Speed Bins

Speed Bin		DDR3-2133N			
CL-tRCD-tRP		14-14-14			
Symbol	/CAS write latency	min	max	Unit	Notes
tAA		13.09	20.0	ns	
tRCD		13.09	—	ns	
tRP		13.09	—	ns	
tRC		46.09	—	ns	
tRAS		33.0	9 × tREFI	ns	10
tCK(avg) @CL=5	CWL = 5	Reserved	Reserved	ns	4
	CWL = 6, 7, 8, 9, 10	Reserved	Reserved	ns	4
tCK(avg) @CL=6	CWL = 5	2.5	3.3	ns	1, 2, 3, 9, 13
	CWL = 6	Reserved	Reserved	ns	4
	CWL = 7, 8, 9, 10	Reserved	Reserved	ns	4
tCK(avg) @CL=7	CWL = 5	Reserved	Reserved	ns	4
	CWL = 6	1.875	2.5	ns	1, 2, 3, 9, 13
	CWL = 7	Reserved	Reserved	ns	4
	CWL = 8, 9, 10	Reserved	Reserved	ns	4
tCK(avg) @CL=8	CWL = 5	Reserved	Reserved	ns	4
	CWL = 6	1.875	2.5	ns	1, 2, 3, 9, 13
	CWL = 7	Reserved	Reserved	ns	4
	CWL = 8, 9, 10	Reserved	Reserved	ns	4
tCK(avg) @CL=9	CWL = 5, 6	Reserved	Reserved	ns	4
	CWL = 7	1.5	1.875	ns	1, 2, 3, 9, 13
	CWL = 8	Reserved	Reserved	ns	4
	CWL = 9, 10	Reserved	Reserved	ns	4
tCK(avg) @CL=10	CWL = 5, 6	Reserved	Reserved	ns	4
	CWL = 7	1.5	1.875	ns	1, 2, 3, 9, 13
	CWL = 8	Reserved	Reserved	ns	4
	CWL = 9	Reserved	Reserved	ns	4
	CWL = 10	Reserved	Reserved	ns	4
tCK(avg) @CL=11	CWL = 5, 6, 7	Reserved	Reserved	ns	4
	CWL = 8	1.25	1.5	ns	1, 2, 3, 9, 13
	CWL = 9	Reserved	Reserved	ns	4
	CWL = 10	Reserved	Reserved	ns	4
tCK(avg) @CL=12	CWL = 5, 6, 7, 8	Reserved	Reserved	ns	4
	CWL = 9	Reserved	Reserved	ns	4
	CWL = 10	Reserved	Reserved	ns	4
tCK(avg) @CL=13	CWL = 5, 6, 7, 8	Reserved	Reserved	ns	4
	CWL = 9	1.07	1.25	ns	1, 2, 3, 9, 13
	CWL = 10	Reserved	Reserved	ns	4
tCK(avg) @CL=14	CWL = 5, 6, 7, 8, 9	Reserved	Reserved	ns	4
	CWL = 10	0.938	1.07	ns	1, 2, 3, 13
Supported CL settings		6, 7, 8, 9, 10, 11, 13, 14		nCK	
Supported CWL settings		5, 6, 7, 8, 9, 10		nCK	

- Notes:
1. The CL setting and CWL setting result in tCK(avg)min and tCK(avg)max requirements. When making a selection of tCK(avg), both need to be fulfilled: Requirements from CL setting as well as requirements from CWL setting.
  2. tCK(avg)min limits: Since /CAS latency is not purely analog - data and strobe output are synchronized by the DLL - all possible intermediate frequencies may not be guaranteed. An application should use the next smaller JEDEC standard tCK(avg) value (3.0, 2.5, 1.875, 1.5, 1.25, 1.071 or 0.938ns) when calculating  $CL(nCK) = tAA(ns) / tCK(avg)(ns)$ , rounding up to the next 'Supported CL'.
  3. tCK(avg)max limits: Calculate tCK(avg) + tAA(max)/CL selected and round the resulting tCK(avg) down to the next valid speed bin (i.e. 3.3ns or 2.5ns or 1.875ns or 1.25ns). This result is tCK(avg)max corresponding to CL selected.
  4. Reserved' settings are not allowed. User must program a different value.
  5. Any DDR3-1066 speed bin also supports functional operation at lower frequencies as shown in the table DDR3-1066 Speed Bins which are not subject to production tests but verified by design/characterization.
  6. Any DDR3-1333 speed bin also supports functional operation at lower frequencies as shown in the table DDR3-1333 Speed Bins which is not subject to production tests but verified by design/characterization.
  7. Any DDR3-1600 speed bin also supports functional operation at lower frequencies as shown in the table DDR3-1600 Speed Bins which is not subject to production tests but verified by design/characterization.
  8. Any DDR3-1866 speed bin also supports functional operation at lower frequencies as shown in the table DDR3-1866 Speed Bins which is not subject to production tests but verified by design/characterization.
  9. Any DDR3-2133 speed bin also supports functional operation at lower frequencies as shown in the table DDR3-2133 Speed Bins which is not subject to production tests but verified by design/characterization.
  10. tREFI depends on operating case temperature (TC).
  11. For devices supporting optional down binning to CL = 7, CL = 9 and CL = 11, tAA/tRCD/tRP(min) must be 13.125 ns or lower. SPD settings must be programmed to match.
  12. DDR3-800 AC timing apply if DRAM operates at lower than 800 MT/s data rate.
  13. Spread spectrum is not included in the jitter specification values. However, the input clock can accommodate spread-spectrum at a sweep rate in the range of 20kHz - 60 kHz with an additional 1% of tCK(avg) as a long-term jitter component; however, the spread spectrum may not use a clock rate below tCK(avg)min.

### 3. Package Drawing

#### 3.1 78-ball FBGA

Solder ball: Lead free (Sn-Ag-Cu)

Unit: mm

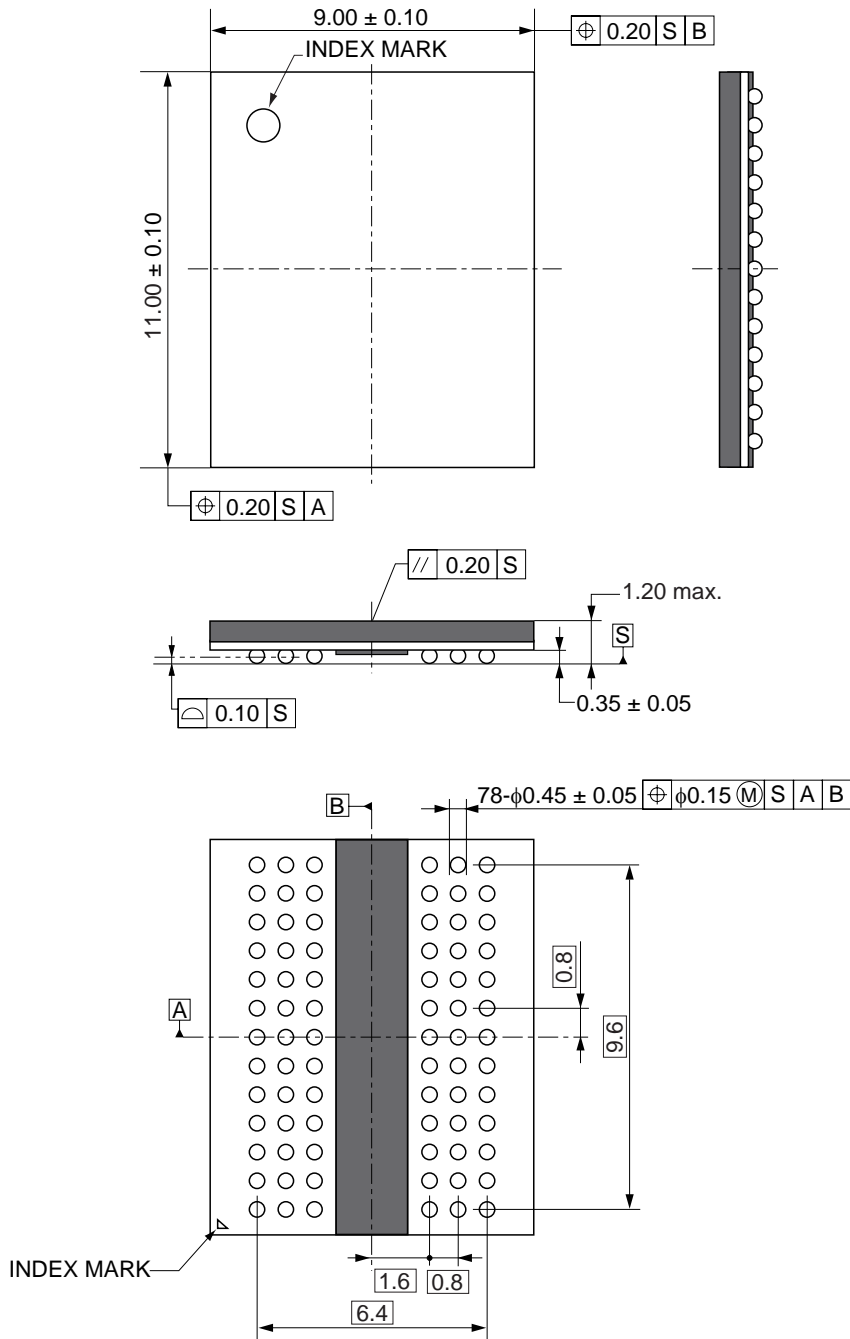

ECA-TS2-0381-01

3.2 96-ball FBGA

Solder ball: Lead free (Sn-Ag-Cu)

Unit: mm

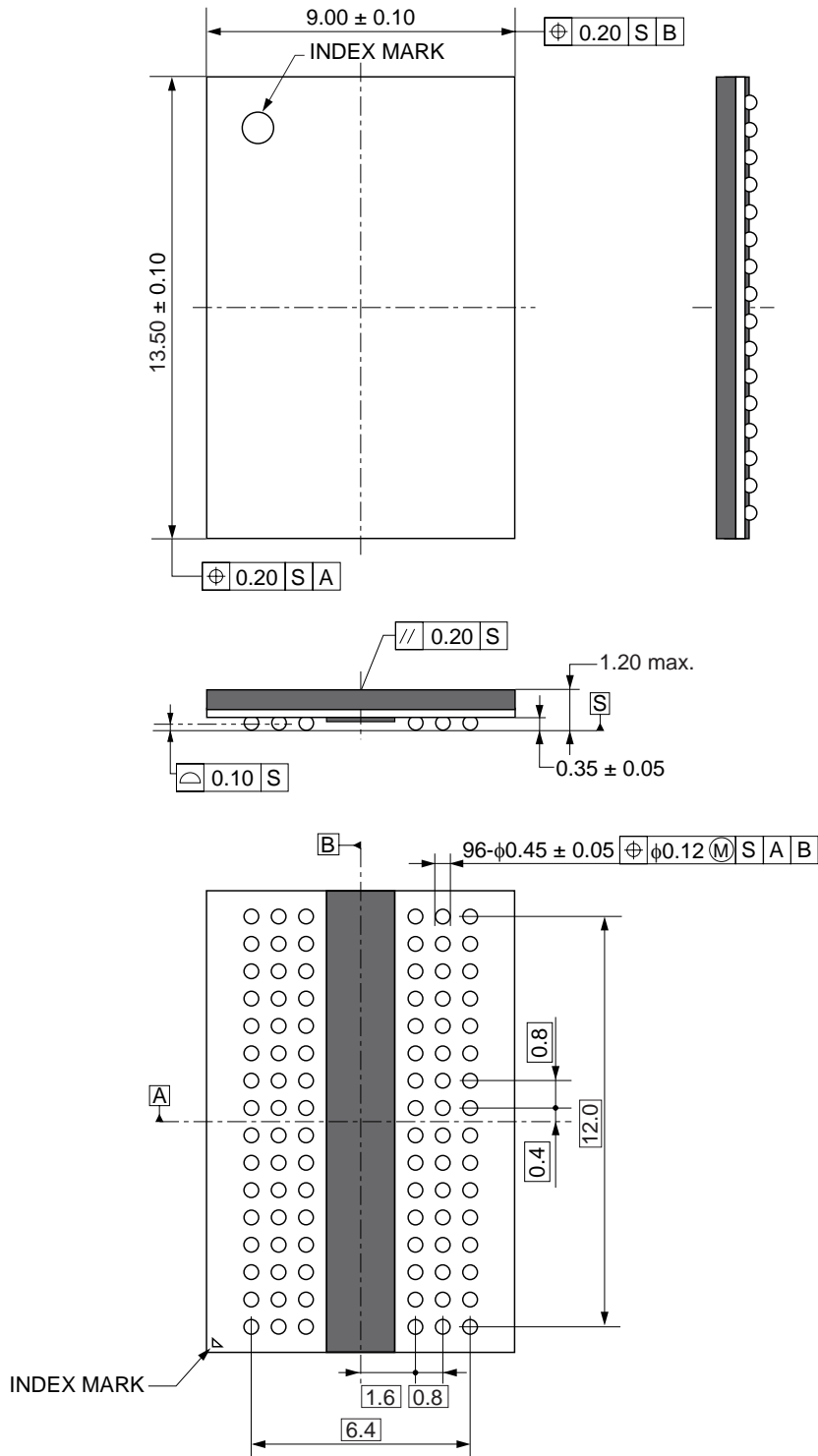

ECA-TS2-0382-01

#### **4. Recommended Soldering Conditions**

Please consult with our sales offices for soldering conditions of the 2G bits DDR3 SDRAM.

##### **Type of Surface Mount Device**

EDJ2108DEBG: 78-ball FBGA < Lead free (Sn-Ag-Cu) >

EDJ2116DEBG: 96-ball FBGA < Lead free (Sn-Ag-Cu) >

**NOTES FOR CMOS DEVICES****① PRECAUTION AGAINST ESD FOR MOS DEVICES**

Exposing the MOS devices to a strong electric field can cause destruction of the gate oxide and ultimately degrade the MOS devices operation. Steps must be taken to stop generation of static electricity as much as possible, and quickly dissipate it, when once it has occurred. Environmental control must be adequate. When it is dry, humidifier should be used. It is recommended to avoid using insulators that easily build static electricity. MOS devices must be stored and transported in an anti-static container, static shielding bag or conductive material. All test and measurement tools including work bench and floor should be grounded. The operator should be grounded using wrist strap. MOS devices must not be touched with bare hands. Similar precautions need to be taken for PW boards with semiconductor MOS devices on it.

**② HANDLING OF UNUSED INPUT PINS FOR CMOS DEVICES**

No connection for CMOS devices input pins can be a cause of malfunction. If no connection is provided to the input pins, it is possible that an internal input level may be generated due to noise, etc., hence causing malfunction. CMOS devices behave differently than Bipolar or NMOS devices. Input levels of CMOS devices must be fixed high or low by using a pull-up or pull-down circuitry. Each unused pin should be connected to  $V_{DD}$  or GND with a resistor, if it is considered to have a possibility of being an output pin. The unused pins must be handled in accordance with the related specifications.

**③ STATUS BEFORE INITIALIZATION OF MOS DEVICES**

Power-on does not necessarily define initial status of MOS devices. Production process of MOS does not define the initial operation status of the device. Immediately after the power source is turned ON, the MOS devices with reset function have not yet been initialized. Hence, power-on does not guarantee output pin levels, I/O settings or contents of registers. MOS devices are not initialized until the reset signal is received. Reset operation must be executed immediately after power-on for MOS devices having reset function.

CME0107

The information in this document is subject to change without notice. Before using this document, confirm that this is the latest version.

No part of this document may be copied or reproduced in any form or by any means without the prior written consent of Elpida Memory, Inc.

Elpida Memory, Inc. does not assume any liability for infringement of any intellectual property rights (including but not limited to patents, copyrights, and circuit layout licenses) of Elpida Memory, Inc. or third parties by or arising from the use of the products or information listed in this document. No license, express, implied or otherwise, is granted under any patents, copyrights or other intellectual property rights of Elpida Memory, Inc. or others.

Descriptions of circuits, software and other related information in this document are provided for illustrative purposes in semiconductor product operation and application examples. The incorporation of these circuits, software and information in the design of the customer's equipment shall be done under the full responsibility of the customer. Elpida Memory, Inc. assumes no responsibility for any losses incurred by customers or third parties arising from the use of these circuits, software and information.

**[Product applications]**

Be aware that this product is for use in typical electronic equipment for general-purpose applications. Elpida Memory, Inc. makes every attempt to ensure that its products are of high quality and reliability. However, this product is not intended for use in the product in aerospace, aeronautics, nuclear power, combustion control, transportation, traffic, safety equipment, medical equipment for life support, or other such application in which especially high quality and reliability is demanded or where its failure or malfunction may directly threaten human life or cause risk of bodily injury. Customers are instructed to contact Elpida Memory's sales office before using this product for such applications.

**[Product usage]**

Design your application so that the product is used within the ranges and conditions guaranteed by Elpida Memory, Inc., including the maximum ratings, operating supply voltage range, heat radiation characteristics, installation conditions and other related characteristics. Elpida Memory, Inc. bears no responsibility for failure or damage when the product is used beyond the guaranteed ranges and conditions. Even within the guaranteed ranges and conditions, consider normally foreseeable failure rates or failure modes in semiconductor devices and employ systemic measures such as fail-safes, so that the equipment incorporating Elpida Memory, Inc. products does not cause bodily injury, fire or other consequential damage due to the operation of the Elpida Memory, Inc. product.

**[Usage environment]**

Usage in environments with special characteristics as listed below was not considered in the design. Accordingly, our company assumes no responsibility for loss of a customer or a third party when used in environments with the special characteristics listed below.

Example:

- 1) Usage in liquids, including water, oils, chemicals and organic solvents.
- 2) Usage in exposure to direct sunlight or the outdoors, or in dusty places.
- 3) Usage involving exposure to significant amounts of corrosive gas, including sea air, CL<sub>2</sub>, H<sub>2</sub>S, NH<sub>3</sub>, SO<sub>2</sub>, and NO<sub>x</sub>.
- 4) Usage in environments with static electricity, or strong electromagnetic waves or radiation.
- 5) Usage in places where dew forms.
- 6) Usage in environments with mechanical vibration, impact, or stress.
- 7) Usage near heating elements, igniters, or flammable items.

If you export the products or technology described in this document that are controlled by the Foreign Exchange and Foreign Trade Law of Japan, you must follow the necessary procedures in accordance with the relevant laws and regulations of Japan. Also, if you export products/technology controlled by U.S. export control regulations, or another country's export control laws or regulations, you must follow the necessary procedures in accordance with such laws or regulations.

If these products/technology are sold, leased, or transferred to a third party, or a third party is granted license to use these products, that third party must be made aware that they are responsible for compliance with the relevant laws and regulations.

M01E1007