



Dear customers,

**About the change in the name such as "Oki Electric Industry Co. Ltd." and "OKI" in documents to OKI Semiconductor Co., Ltd.**

The semiconductor business of Oki Electric Industry Co., Ltd. was succeeded to OKI Semiconductor Co., Ltd. on October 1, 2008. Therefore, please accept that although the terms and marks of "Oki Electric Industry Co., Ltd.", "Oki Electric", and "OKI" remain in the documents, they all have been changed to "OKI Semiconductor Co., Ltd.". It is a change of the company name, the company trademark, and the logo, etc. , and NOT a content change in documents.

October 1, 2008  
OKI Semiconductor Co., Ltd.

**OKI SEMICONDUCTOR CO., LTD.**

550-1 Higashiasakawa-cho, Hachioji-shi, Tokyo 193-8550, Japan  
<http://www.okisemi.com/en/>

---

---

# MSC1205

---

## 32-Bit Duplex Controller/Driver with Digital Dimming Function

---

### GENERAL DESCRIPTION

The MSC1205 is a Bi-CMOS display driver for a 1/2-duty vacuum fluorescent display tube. It consists of a 64-bit shift register, latch circuits, a digital dimming circuit, and drivers. The MSC1205 provides an interface with a microcomputer only by three signal lines: LOAD, DATA, and CLOCK.

### FEATURES

- Power Supply Voltage: 8 to 18V (built-in 5V regulator for logic)
- Built-in 1-terminal RC oscillation circuit (with external capacitor)
- Built-in digital dimming circuit  
10-bit resolution  
Programmable in the duty range of 0/2048 (0%) to 1015.5/2048 (49.6%).
- Can directly drive  $32 \times 2$  display anodes.
- Built-in power-on reset circuit
- Package options:  
42-pin plastic DIP (DIP42-P-600-2.54) (Product name: MSC1205-RS)  
44-pin plastic QFP (QFP44-P-910-0.80-2K) (Product name: MSC1205GS-2K)

**BLOCK DIAGRAM**

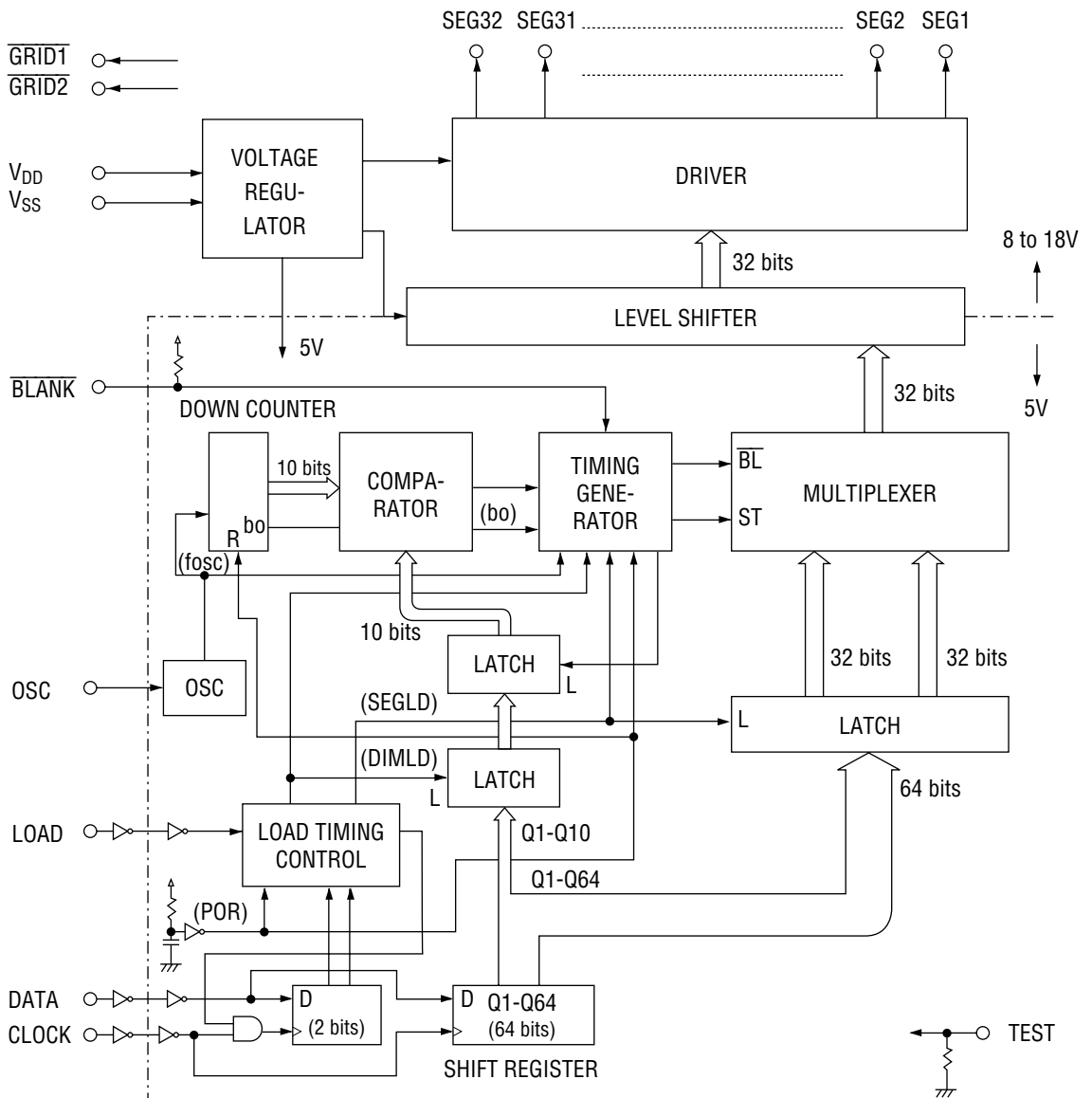

### INPUT AND OUTPUT CONFIGURATION

- Schematic Diagrams of Logic Portion Input Circuit 1

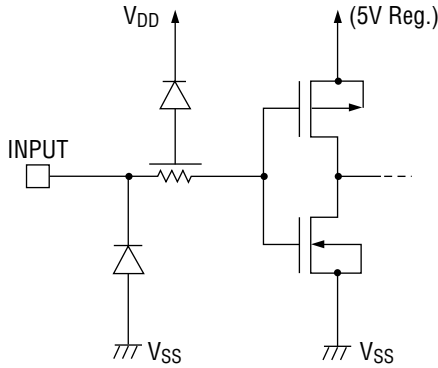

- Schematic Diagrams of Logic Portion Input Circuit 2

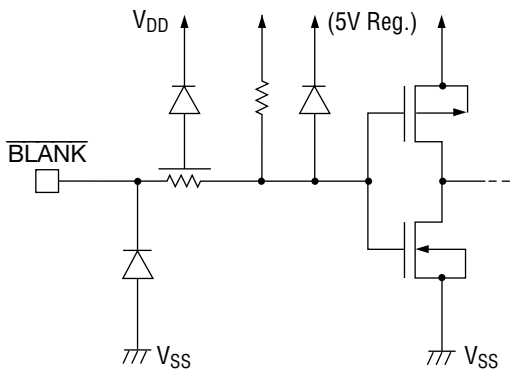

- Schematic Diagrams of Logic Portion Input Circuit 3

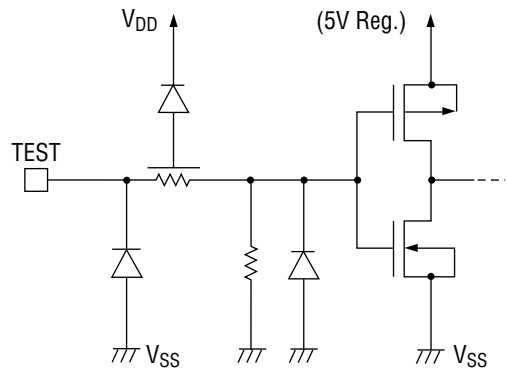

- Schematic Diagrams of Driver Output Circuit

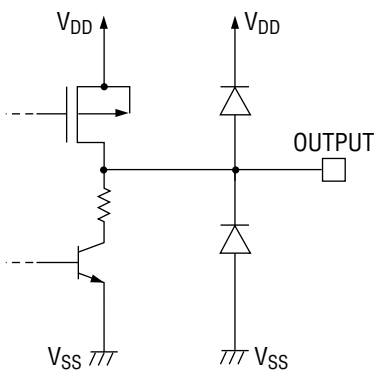

**PIN CONFIGURATION (TOP VIEW)**

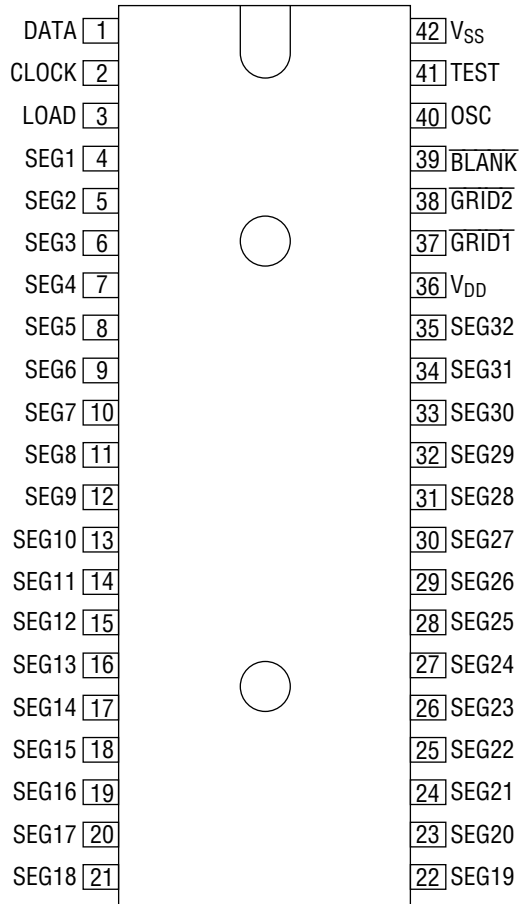

**42-Pin Plastic DIP**

**PIN CONFIGURATION (TOP VIEW)**

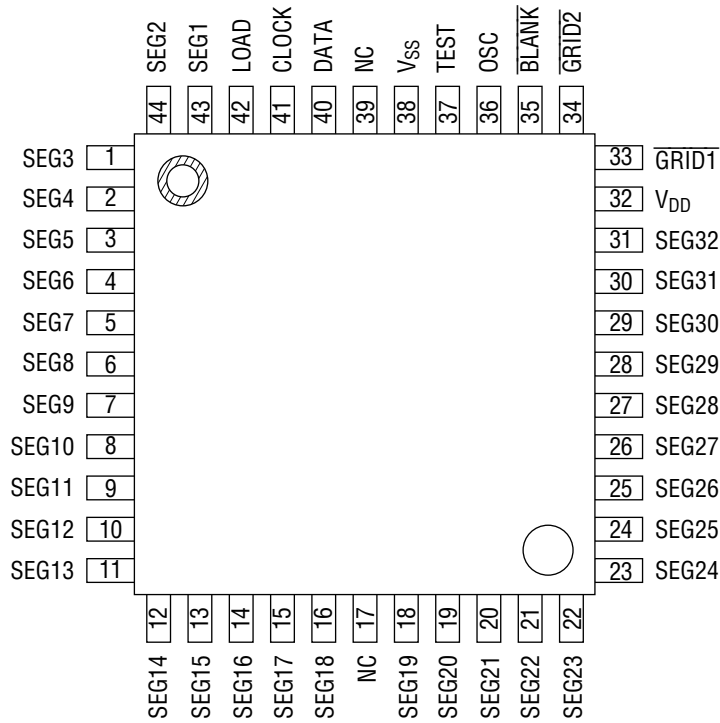

NC : No-connection pin

**44-Pin Plastic QFP**

## PIN DESCRIPTION

Symbol	Type	Description
DATA	I	Serial data input pin. This pin receives display data, dimming data, enable bit and mode bit.
CLOCK	I	Shift clock input pin with Schmitt circuit. Serial data is clocked in this pin at the rising edge of the shift clock pulse.
LOAD	I	Load pulse input pin. The load signal is input when dimming data and segment data transfer is finished.
SEG1 -SEG32	0	Segment driver output pins. These pins provide large current driving ( $I_{OH} = -5.5\text{mA}$ at $V_{DD} = 12\text{V}$ ) and small current driving ( $I_{OH} = -1.8\text{mA}$ at $V_{DD} = 12\text{V}$ ).
$V_{DD}$	—	Power supply voltage. This pin is connected to a power supply of 8 to 18V.
$\overline{\text{GRID1}}$	0	Grid driver output pin. When this pin is set to "L", the display is turned on. This pin is connected to external PNP transistor. The segment data of the first bit (S1) to the 32nd bit (S32) is valid in the segment data of 64 bits.
$\overline{\text{GRID2}}$	0	Grid driver output pin. When this pin is set to "L", the display is turned on. This pin is connected to external PNP transistor. The segment data of the 33rd bit (S33) to the 64th bit (S64) is valid in the segment data of 64 bits.
$\overline{\text{BLANK}}$	I	Display blank input pin with a pull-up resistor. When this pin is set to "L", the display is turned off (SEGN = "L")
OSC	I	Oscillation input pin. This pin is connected to an external capacitor of 82pF. A standard oscillation frequency is 512kHz.
TEST	I	Test input pin with a pull-down resistor. Normally this pin should be left open or should be connected to ground.
$V_{SS}$	—	Ground pin. This pin is connected to ground ( $V_{SS} = 0$ )

## ABSOLUTE MAXIMUM RATINGS

Parameter	Symbol	Condition	Rating	Unit
Supply Voltage	$V_{DD}$	$T_a = 25^\circ\text{C}$	-0.3 to +20	V
Input Voltage	$V_{IN}$	$T_a = 25^\circ\text{C}$	-0.3 to +6.0	V
Storage Temperature Range	$T_{STG}$	—	-65 to +150	$^\circ\text{C}$

## RECOMMENDED OPERATING CONDITIONS

Parameter	Symbol	Condition	Range	Unit
Power Supply Voltage	$V_{DD}$	—	8 to 18	V
Operating Temperature Range	$T_{op}$	—	-40 to +85	$^\circ\text{C}$

## ELECTRICAL CHARACTERISTICS

### DC Characteristics

( $T_a = -40$  to  $+85^\circ\text{C}$ ,  $V_{DD} = 8$  to  $18\text{V}$ )

Parameter	Symbol	Condition	Min.	Max.	Unit	Applicable pin
High Level Input Voltage	$V_{IH}$	—	3.8	5.5	V	—
Low Level Input Voltage	$V_{IL}$	—	-0.3	0.8	V	—
High Level Input Current	$I_{IH1}$	$V_I = 5\text{V}$	-1	1	$\mu\text{A}$	DATA, LOAD CLOCK
	$I_{IH3}$	$V_I = 5\text{V}$	—	500	$\mu\text{A}$	TEST
Low Level Input Current	$I_{IL1}$	$V_I = 0\text{V}$	-1	1	$\mu\text{A}$	DATA, LOAD CLOCK
	$I_{IL2}$	$V_I = 0\text{V}$	-500	-100	$\mu\text{A}$	BLANK
	$I_{IL3}$	$V_I = 0\text{V}$	-1	1	$\mu\text{A}$	TEST
High Level Output Voltage (1) (Small Current Driver)	$V_{OH1}$	$V_{DD} = 9.5\text{V}$ , $I_{OH1} = -1.3\text{mA}$	$V_{DD}-0.5$	—	V	SEG (2n) n = 1-16
	$V_{OH2}$	$V_{DD} = 12\text{V}$ , $I_{OH2} = -1.8\text{mA}$	$V_{DD}-0.5$	—	V	
	$V_{OH3}$	$V_{DD} = 15\text{V}$ , $I_{OH3} = -2.3\text{mA}$	$V_{DD}-0.5$	—	V	
High Level Output Voltage (2) (Large Current Driver)	$V_{OH4}$	$V_{DD} = 9.5\text{V}$ , $I_{OH4} = -4.1\text{mA}$	$V_{DD}-0.5$	—	V	SEG (2n-1) n = 1-16
	$V_{OH5}$	$V_{DD} = 12\text{V}$ , $I_{OH5} = -5.5\text{mA}$	$V_{DD}-0.5$	—	V	
	$V_{OH6}$	$V_{DD} = 15\text{V}$ , $I_{OH6} = -7.0\text{mA}$	$V_{DD}-0.5$	—	V	
Low Level Output Voltage	$V_{OL1}$	$V_{DD} = 9.5\text{V}$ , $I_{OL1} = 1\text{mA}$	—	4	V	SEG1-SEG32 GRID1, GRID2
	$V_{OL2}$	$V_{DD} = 9.5\text{V}$ , $I_{OL2} = 500\mu\text{A}$	—	2	V	
	$V_{OL3}$	$V_{DD} = 9.5\text{V}$ , $I_{OL3} = 2\mu\text{A}$	—	0.3	V	
High Level Output Voltage (3)	$V_{OH7}$	$V_{DD} = 9.5\text{V}$ , $I_{OH7} = -0.8\text{mA}$	$V_{DD}-0.5$	—	V	GRID1, GRID2
Current Consumption	$I_{DD}$	$f_{OSC} = 512\text{kHz}$ , no load	—	20	mA	—

AC Characteristics

( $T_a = -40$  to  $+85^\circ\text{C}$ ,  $V_{DD} = 8$  to  $18\text{V}$ )

Parameter	Symbol	Condition	Min.	Typ.	Max.	Unit	
Clock Frequency	$f_C(1/t_{\text{clock}})$	—	—	—	1	MHz	
Clock Pulse Width	$t_{\text{CW}}$	—	500	—	—	ns	
Clock Rise/Fall Time	$t_{\text{cr}}, t_{\text{cf}}$	—	—	—	500	ns	
DATA Setup Time	$t_{\text{DS}}$	—	200	—	—	ns	
DATA Hold Time	$t_{\text{DH}}$	—	200	—	—	ns	
Clock → Load Time	$t_{\text{CL}}$	—	100	—	—	ns	
Load → Clock Time	$t_{\text{LC}}$	—	50	—	—	ns	
Load Pulse Width	$t_{\text{LW}}$	—	1.3	—	—	$\mu\text{s}$	
SEGN Rise/Fall Time	Large Current	$t_r, t_f$	$C_L = 20\text{pF}$	0	4/120	400	ns
	Small Current	$t_r, t_f$	$C_L = 20\text{pF}$	0	15/120	400	ns
Grid Frequency	$f_{\text{GRID}}$	$C_L = 82\text{pF} \pm 5\%$	150	250	350	Hz	
Oscillation Frequency	$f_{\text{OSC}}$		307.2	512	716.8	kHz	

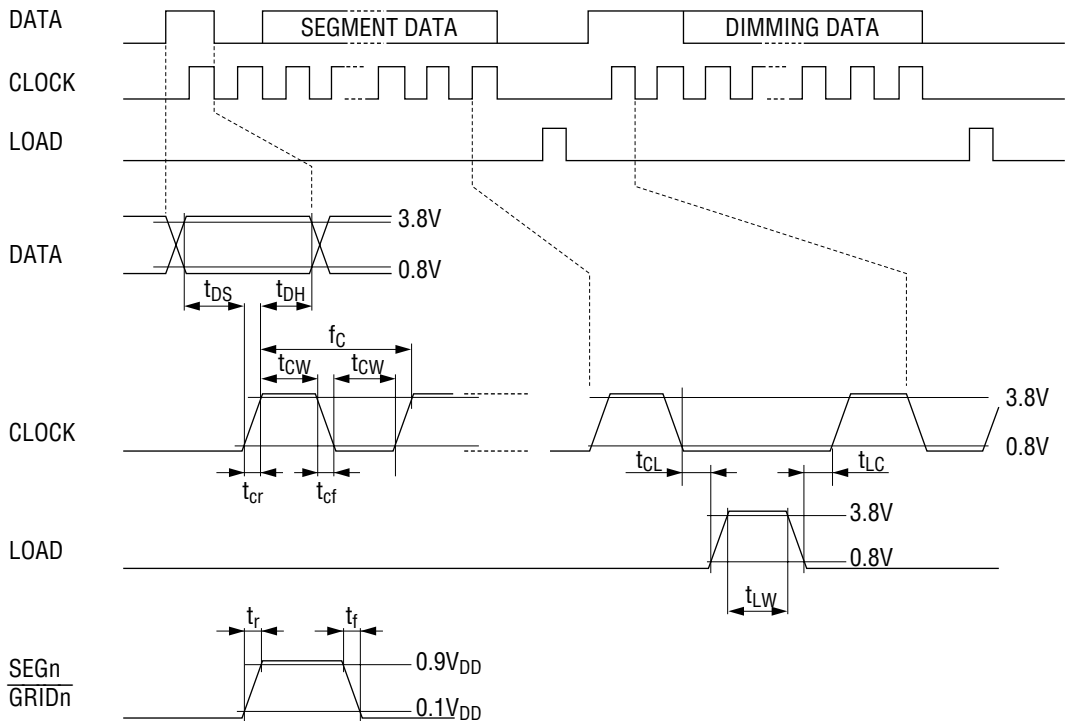

## FUNCTIONAL DESCRIPTION

### DATA Input

This device uses 10-bit dimming and 64-bit segment data.

In order to transfer this data, the enable bit (M0) and mode bit (M1) should be set to an initial state. The data format is shown below.

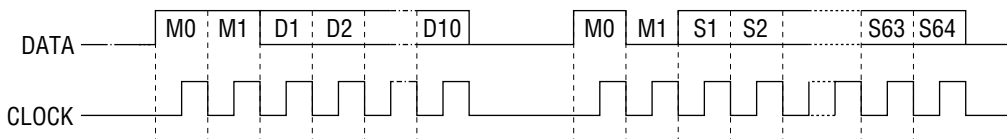

**Figure 1. Data Transfer Timing**

M0 : This bit is an enable bit.

M0 = "0" : Subsequent data is disabled; preceding data is held.

M0 = "1" : The beginning of data transfer. The following data is clocked in sequentially.

M1 : This bit is used to select the mode.

M1 = "0" : Subsequent data is handled as the segment data.

M1 = "1" : Subsequent data is handled as the dimming data.

D1 : LSB of dimming data.

S1 : data for grid1 of SEG1.

S2 : data for grid1 of SEG2.

⋮

S32 : data for grid1 of SEG32.

S33 : data for grid2 of SEG1.

⋮

S64 : data for grid2 of SEG32.

- Notes:
1. Be sure to set the enable bit to "1" before data is transferred. Data following M0 is handled to be enable. If data is input with the enable bit not set to "1", the first "1" data coming next is handled as the enable bit.
  2. If the number of the data bits applied is greater (for example, 67 bits are applied for the segment data of 64 bits), the data bits are pushed out in the same order that they are applied, and thus S1, S2, and S3 are ignored.
  3. If the number of the data bits applied is smaller (for example, 62 bits are applied for the segment data of 64 bits), S63 and S64 prior to data transfer are shifted to S1 and S2 respectively.

**CLOCK Input**

DATA is shifted at the rising edge of the clock.

**LOAD Input**

The contents of the shift register are shifted in while the LOAD input is "H" and latched at "H" to "L" transition.

The LOAD signal is reproduced in the VF driver for the latch pulse for dimming data and segment data.

After 10-bit dimming data and 64-bit segment data are transferred, input the LOAD signal prior to the next clock.

**Blank Function**

A low-level voltage at the  $\overline{\text{BLANK}}$  pin turns the display off (segment output = "L"). When segment data transfer is finished, the display is turned on.

The relationship between this data transfer and the display is shown in Figure 2.

**Initial Setting**

When powered on (i.e., when the segment data has never been transferred) the display is turned off (the segment output is "L").

When segment data transfer is finished, display is turned on. The relationship between this data transfer and the display is shown in Figure 2.

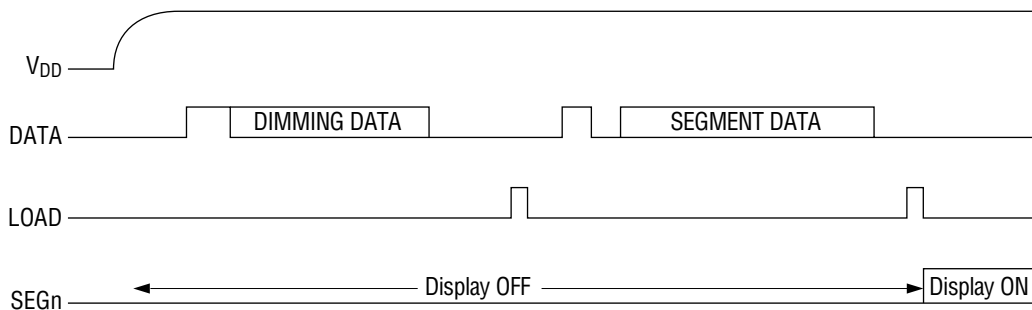

**Figure 2. Relationship Between Data Transfer and Display**

If the segment data is transferred before the dimming data is transferred after powered on, the display is turned on at the completion of segment data transfer, with undefined dimming values. The relationship between data transfer and display is shown in Figure. 3.

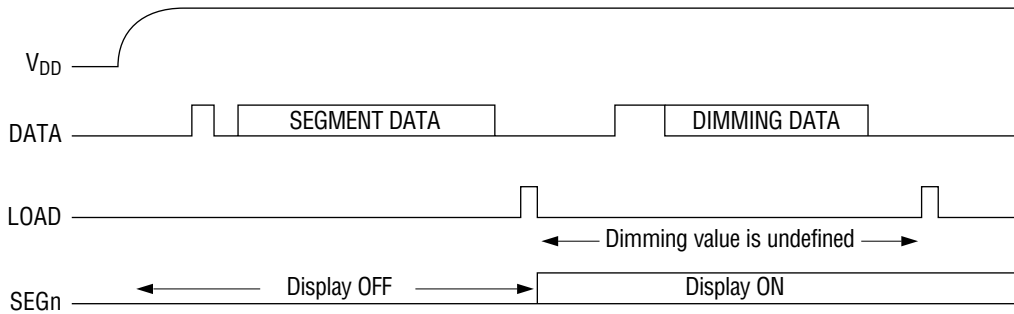
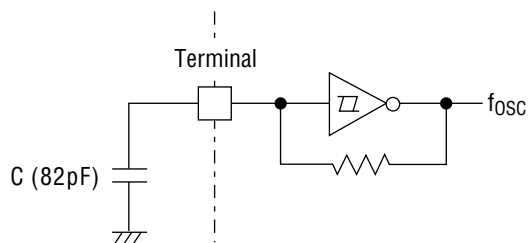

**Figure 3. Relationship Between Advance Transfer of Segment Data and Display**

**Oscillator**

Connect an external capacitor (C), as shown in Figure 4. The oscillating frequency  $f_{OSC}$  depends on the external capacitor used. The following equation is true between  $f_{OSC}$  and grid frequency ( $f_{GRID}$ ):

$$f_{GRID} = f_{OSC} / 2048$$



**Figure 4. Oscillation Equivalent Circuit**

**Dimming Function**

The duty cycle of grid output can be changed in 1/2048 step with respect to 10-bit dimming data. Table 1 shows the relationship between dimming data and duty ratio.

**Table 1. Dimming Data and Duty Ratio**

(MSB) dimming data (LSB)			Duty ratio	
00	0000	0000	0/2048	
00	0000	0001	1/2048	
∧	∧	∧	∧	
11	1111	0111	1015/2048	
11	1111	1000	1015.5/2048	Max
∧	∧	∧	∧	↓
11	1111	1110	1015.5/2048	Max

Note: Setting for address 3FF<sub>H</sub> is invalid.

Duty ratios are programmable within the range of 0/2048 (0%) to 1015.5/2048 (49.6%).

APPLICATION CIRCUIT

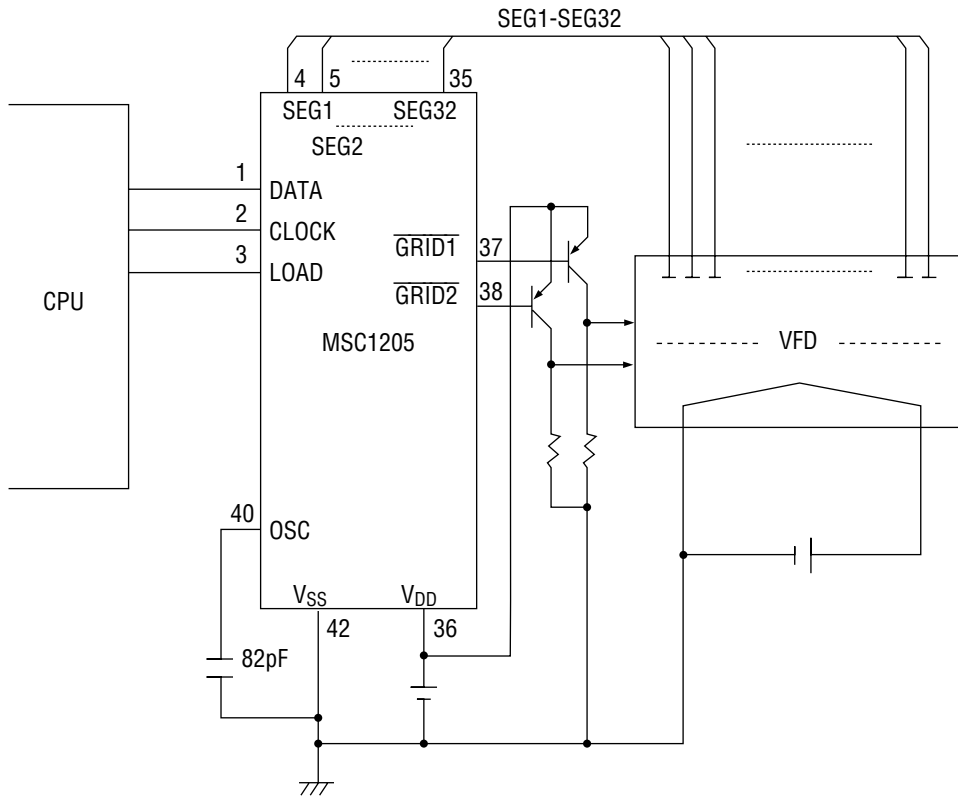

**PACKAGE DIMENSIONS**

(Unit : mm)

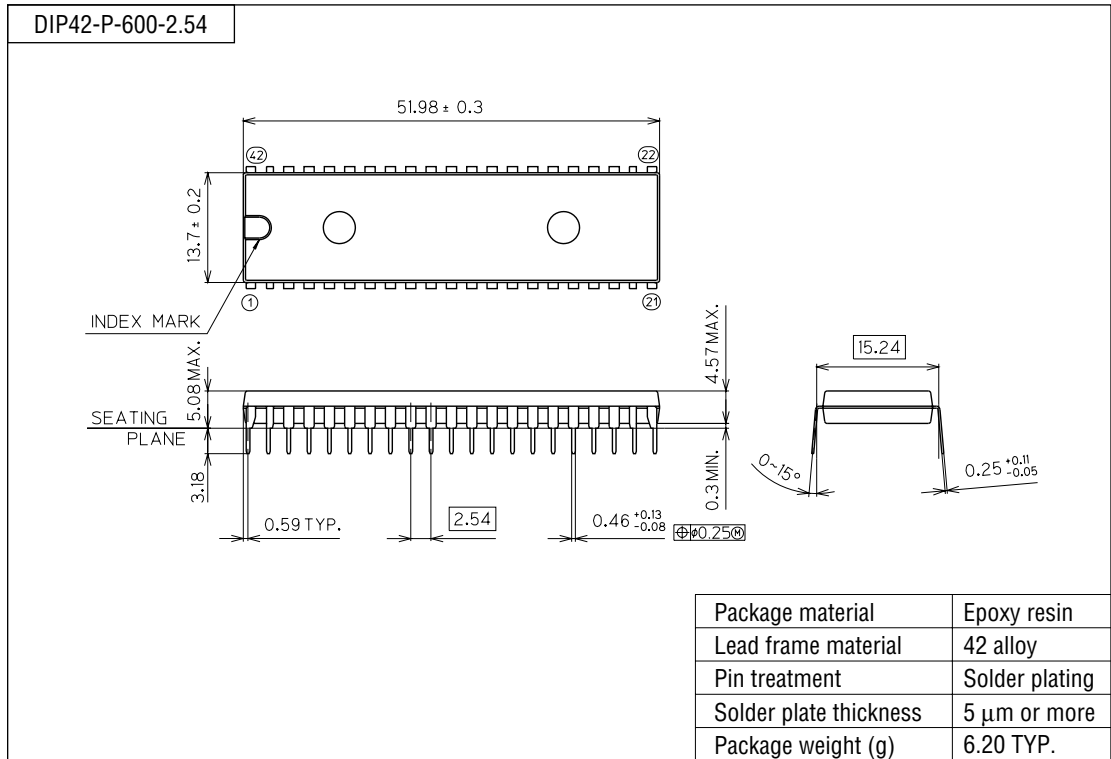

Notes for Mounting the Surface Mount Type Package

The SOP, QFP, TSOP, SOJ, QFJ (PLCC), SHP and BGA are surface mount type packages, which are very susceptible to heat in reflow mounting and humidity absorbed in storage. Therefore, before you perform reflow mounting, contact Oki's responsible sales person for the product name, package name, pin number, package code and desired mounting conditions (reflow method, temperature and times).

(Unit : mm)

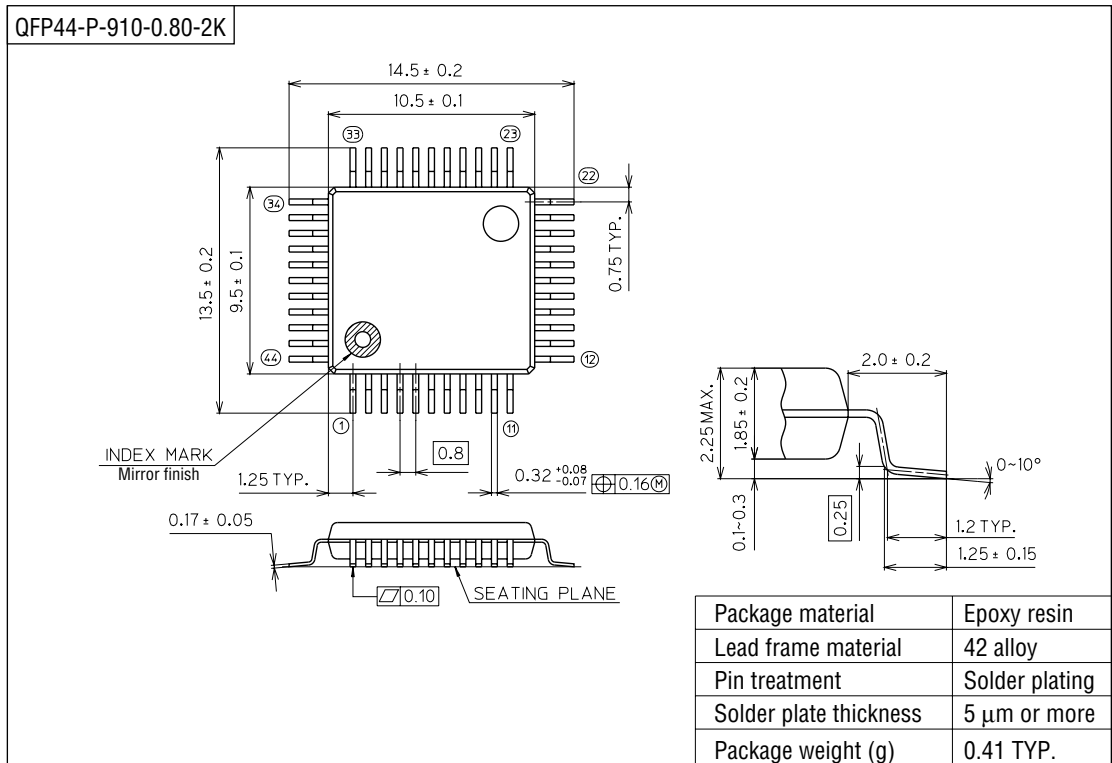

Notes for Mounting the Surface Mount Type Package

The SOP, QFP, TSOP, SOJ, QFJ (PLCC), SHP and BGA are surface mount type packages, which are very susceptible to heat in reflow mounting and humidity absorbed in storage. Therefore, before you perform reflow mounting, contact Oki's responsible sales person for the product name, package name, pin number, package code and desired mounting conditions (reflow method, temperature and times).